

YOSO
LINEAR MOTION

CIRCULAR
GUIDE RAIL

About Us

Jingpeng Machinery Equipment (Shanghai) Co., Ltd. was established in 2015. Its main products include ball screws, linear guides, cross guides, precision ball screws/splines, single-axis actuators, medium and large bearings, racks, couplings, support units, servo motors and drivers, etc. In cooperation with the German YOSO company, Jingpeng has independent import and export rights. Jingpeng has completed trademark registration and continues to promote its use. Now YOSO is one of the world's well-known brands. The company's products are sold all over the world and exported to the United States, Spain, Turkey, Italy, Austria, Brazil and other countries. Jingpeng Machinery learns German production technology, combines European and Japanese design concepts, and has specially established an independent R&D center, introducing advanced manufacturing equipment and high-precision testing equipment at home and abroad, and has completed an annual output value of 1.5 million sets of screw guides.

The product application areas are as follows: Automation industry Robotics industry Semiconductor industry Industrial machinery Medical equipment Green energy industry Machine tools Automatic storage system products have outstanding performance in various industrial fields. Jingpeng Machinery integrates global resources, continues to innovate, and works tirelessly for the better welfare of mankind and a better working environment. In the field of transmission components, Jingpeng Machinery has become the best partner with high-quality professional manufacturing and solutions, and provides technical support and industry analysis to meet customer needs. At the same time, we have a solid business team to ensure the stability of the foreign trade sales system and strong market development capabilities, so that our products can be exported to all parts of the world at the fastest speed. Jingpeng Machinery is a global professional manufacturer of transmission control products and system technology products.

YOSO Circular Guide Rail Series

Arc linear guides include roller linear guides and ball linear guides, which can form precision circular guides; in combination with the drive system, they can form precision circular assembly lines, circular production lines, or circular assembly lines. This type of guide circular assembly line has a more compact structure, higher positioning accuracy, and more configuration options; it is superior to traditional conveying lines in many aspects.

Modern production plants are always looking for ways to reduce production costs. One direction of automation is to combine each workstation as closely as possible, reduce the distance between workpieces, and minimize the space occupied. To achieve this, the workpiece needs to move in a circular motion, which requires the use of a circular line. There are two types of circular lines: traditional non-guide rails and precision guide rails, which are described as follows:

■ Traditional belt type

Belt conveyor line is a relatively simple conveyor line. The wide conveyor belt is wound around two rollers at a certain distance. The rollers rotate, the conveyor belt moves, and the workpiece on the belt moves. The roller conveyor line is similar to the belt conveyor line, except that the belt is replaced by several closely arranged rollers.

In the case of a circular line without a guide rail, the workpiece is fixed on a belt or roller, which is not rigid. The friction force generated by gravity cannot effectively limit the left-right, front-back, and up-and-down movement of the workpiece. To prevent the workpiece from falling out, baffles need to be added on both sides of the belt or roller. Since the workpiece is not fixed on the belt or roller, the workpiece often vibrates; if the shape of the workpiece is complex, it will often stick to the parts of the conveyor line. Fixing the workpiece on the conveyor line by the friction force generated by gravity can neither guarantee good positioning accuracy nor make the conveyor line vertical. The fixed workpiece is not rigid, which limits the moving speed of the conveyor line.

■ Precision linear rail type

The workpiece is fixed on the slide, and the slide rolls on the guide rail through the roller. The guide rail limits the freedom of the slide very well and can only move freely in one direction. Therefore, the guide rail type circular assembly line has higher speed and higher positioning accuracy.

In summary, when you need to achieve precision automation in a small space: the workpiece moves quickly between workstations; after the movement stops, the workpiece has good position accuracy; after the movement stops, additional force can be applied to the workpiece for processing or assembly; then you can choose precision circular guides as the basis of your circular assembly line design.

There are two main ways to use annular guiderail for annular line: runway shape and square:

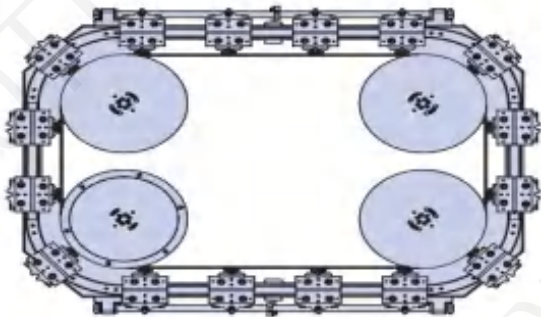
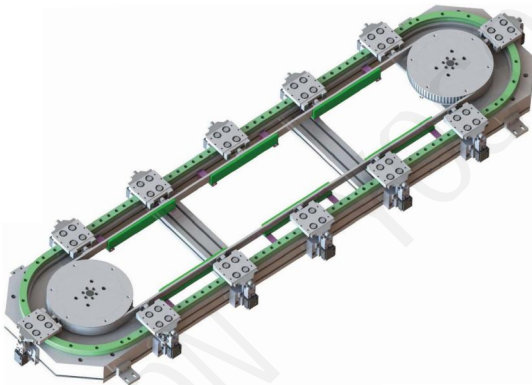

Arc linear guide, coupled with the drive system, becomes an annular assembly line; At present, there are three main driving modes: chain type, synchronous belt type and screw type:

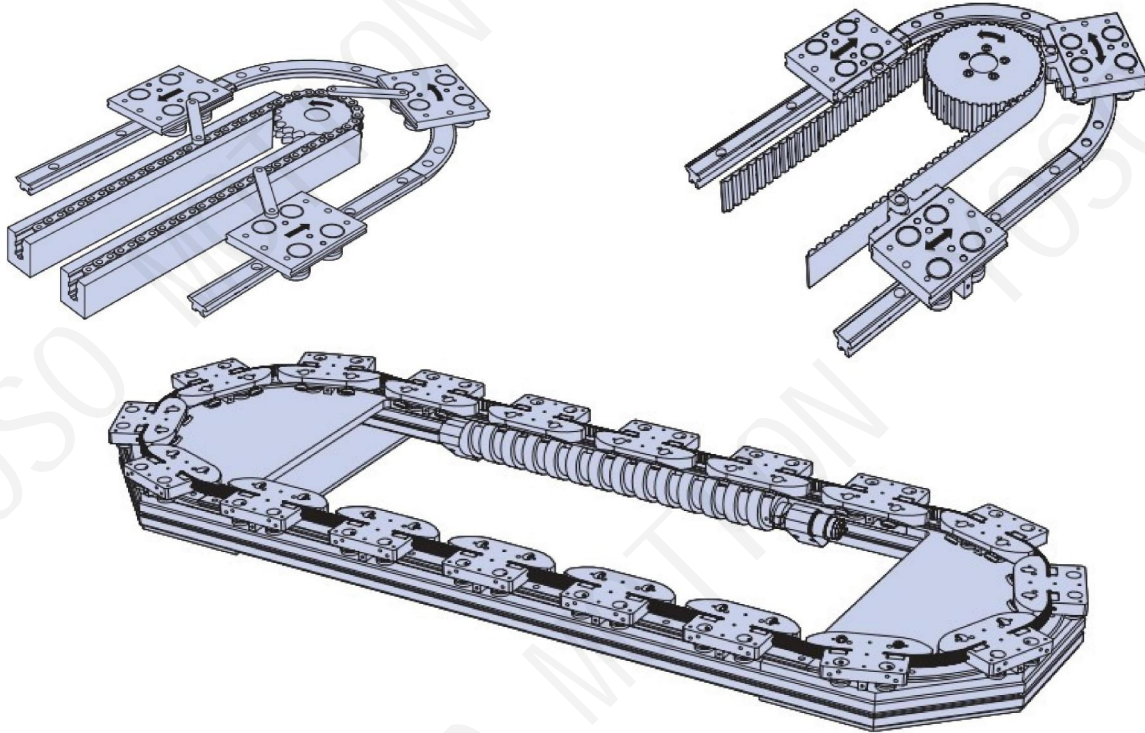

Accessories

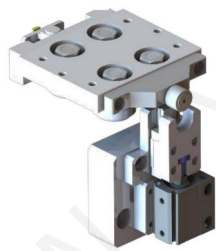

Lifting and positioning mechanism



180°, 90° arc track



360° arc track and slide



Swing arm positioning mechanism

■ T-Ring Rail Model HCP25 Product Drawing

The T-shaped working surface is hardened and has very good wear resistance. The guide rail is precisely ground by CNC guide rail grinder. The guide rail base has no hardness and can be machined. There are three sizes to choose from, and the guide rail can be extended to any length.

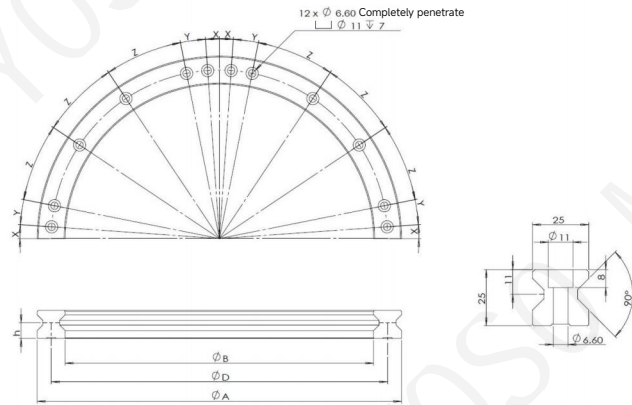

Component Specifications HCP25	Main dimensions											
	B	D	A	h	H	R			X	Y	Z	n*HSpigot
HCP25-200	175	200	225	14	25	90°	180°	360°	22.5			M6
HCP25-255	230	255	280									
HCP25-300	275	300	325									
HCP25-351	326	351	376						4	7.25	22.5	
HCP25-400	375	400	425									
HCP25-468	443	468	493						3	8.25		
HCP25-500	475	500	525									
HCP25-600	575	600	625									
HCP25-700	675	700	725									
HCP25-800	775	800	825									
HCP25-1000	975	1000	1025									

■ T-Ring Rail Model HCP35 Product Drawing

The T-shaped working surface is hardened and has very good wear resistance. The guide rail is precisely ground by CNC guide rail grinder. The guide rail base has no hardness and can be machined. There are three sizes to choose from, and the guide rail can be extended to any length.

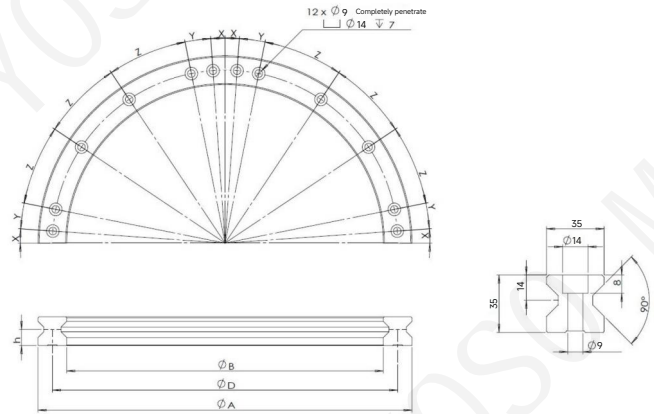

Component Specifications HCP35	Main dimensions											
	B	D	A	h	H	R			X	Y	Z	n*HSpigot
HCP35-300	266	300	334	21	35	90°	180°	360°	12	28	30	M9
HCP35-400	366	400	434									
HCP35-500	466	500	534									
HCP35-600	566	600	634									

■ HCP-RS dimension series table (rectangular)

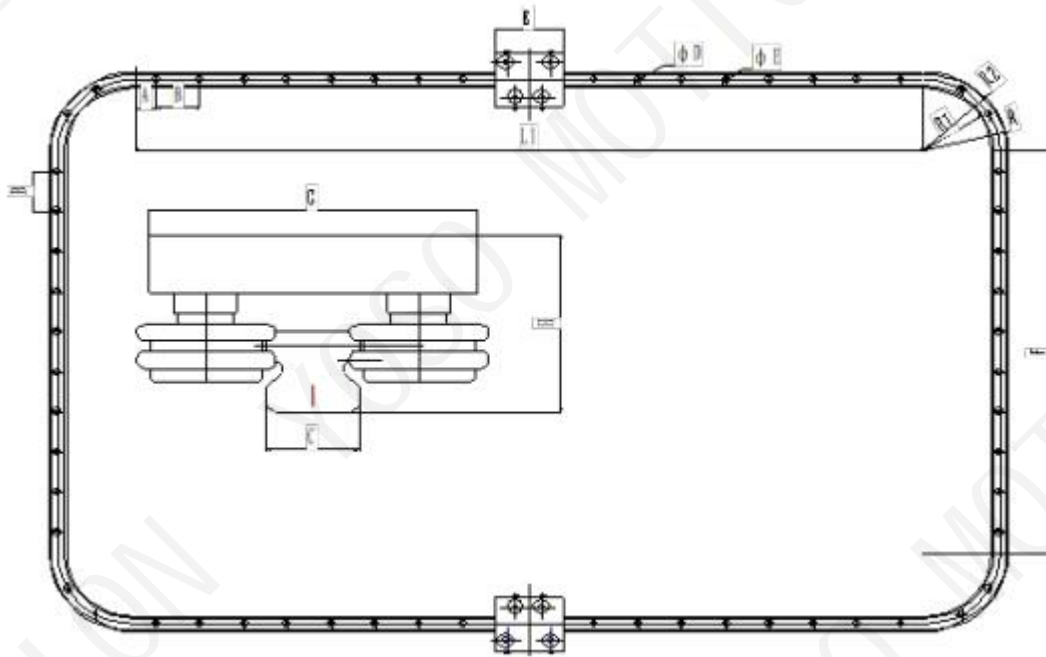
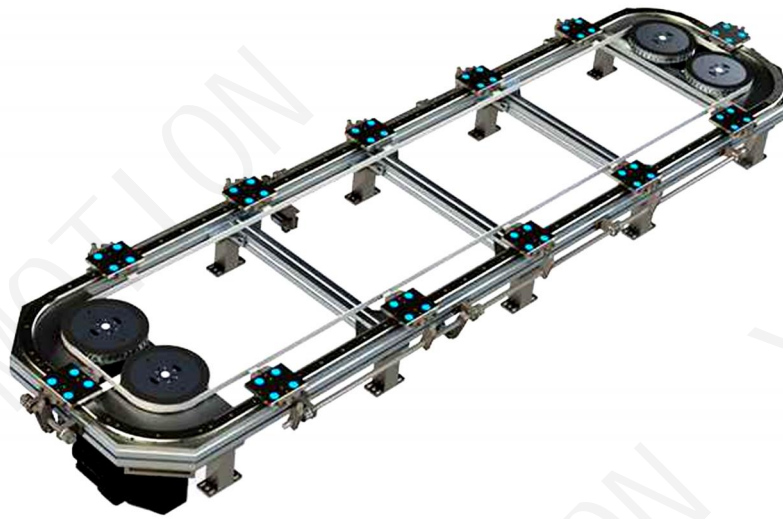

Specifications	A	B	C	D	E	G	H	K	R	R1	R2	L1	Static load (Single block)
HCP-RS-25	30	60	23	7	12	96	52	100	300	277	323	Any size	Maximum 15KG
HCP-RS-35	30	80	35	9	14	100	62	120	280	263	297	Any size	Maximum 50KG

■ HCP-RS dimension series table (rectangular)

HCP - RS - 25 - A15 - R25I + 2300XL + 1600YL

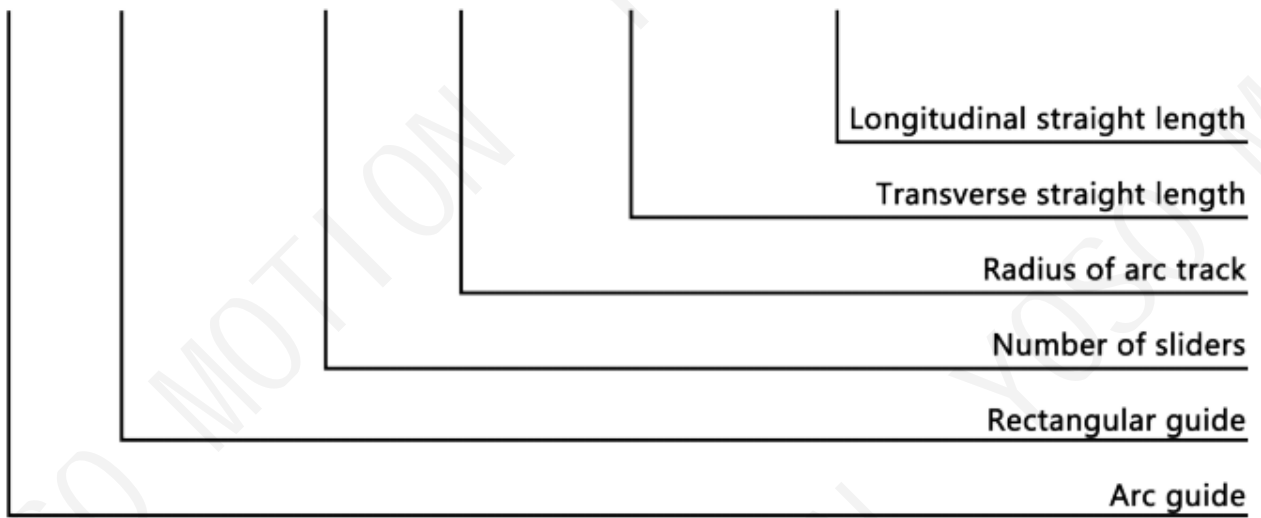

The commonly used radius of arc is 100R/150R/200R/251R/300R. Other radii can be customized according to actual requirements. The minimum radius is 100R and the maximum radius is 300R.

■ HCP-ES dimension series table (ellipse)



■ HCP-ES dimension series table (ellipse)

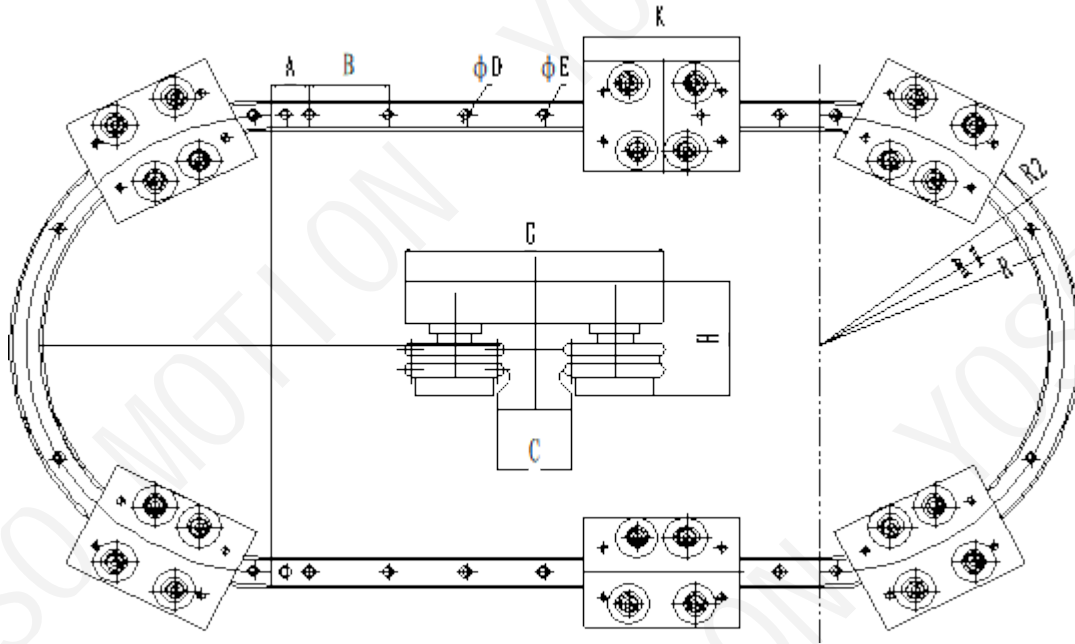

Specifications	A	B	C	D	E	G	H	K	R	R1	R2	L1	Static load (Single block)
HCP-ES-25	30	60	23	7	12	96	52	100	300	277	323	Any size	Maximum 15KG
HCP-ES-35	30	80	35	9	14	100	62	120	280	263	297	Any size	Maximum 50KG

HCP - ES - 25 - A10 - R251 + 1500L

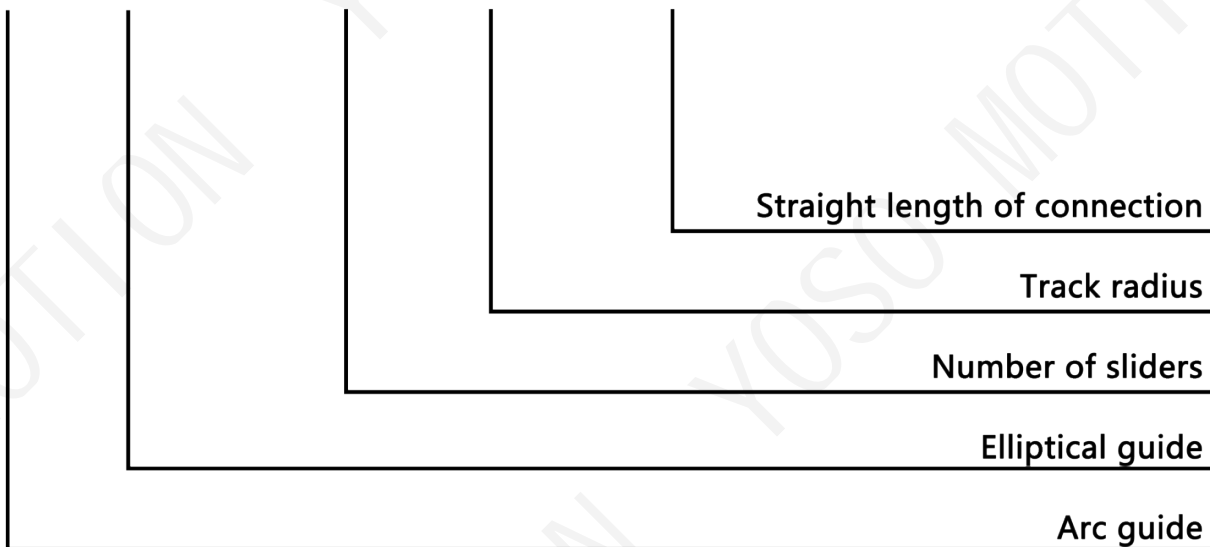

■ Parameter table of annular guide rail operating platform

Project	Content
1	Single slide load()KG
2	Center distance of sliding seat()mm and number of sliding seats()
3	Total length of track installation workbench X wide range()
4	Maximum speed of track operation()m/s
5	Sliding seat positioning accuracy+-()mm
6	How many tooling needs to be accurately positioned()
7	Running time beat from tooling A to tooling B()S
8	Installation mode horizontal/vertical()
9	Length()*width()*height()dimension of tooling object on sliding base
10	Whether the tooling objects bear eccentric load and the size of eccentric load()
11	Whether the sliding seat bears the press mounting force/impact pressure()
12	Operating environment and special instructions()
13	Radius()Line length()or perimeter()
Notes	Note:YOSO products with a radius of less than 300 can be customized with a radius of more than 300.It is recommended to use rectangular structure with four-corner arc

■ System Composition

Track systems combining loop segments with straight runners allow for virtually unlimited open path or closed circuit variations. Both left and right hand bends are negotiable, depending on the runner selected. 90° and 180° segments in all standard double-sided loop sizes are available for straight runners up to 4 meters in length. Straight runners can be butted together to achieve track systems of unlimited length.

Driven track system components 50-51

- Comprehensive range of drive components available from complete proven system.
- Trip latch overload protection
- Carriage positioning and locking system.
- Toothed belt with carriage connection facility.
- Corner support plates.
- Drive and idler pulleys with Hi-load bearing cartridges.
- Support frame with slide attachment facility.

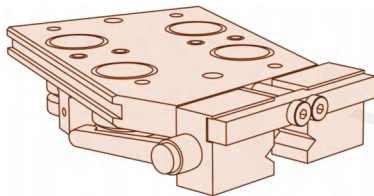
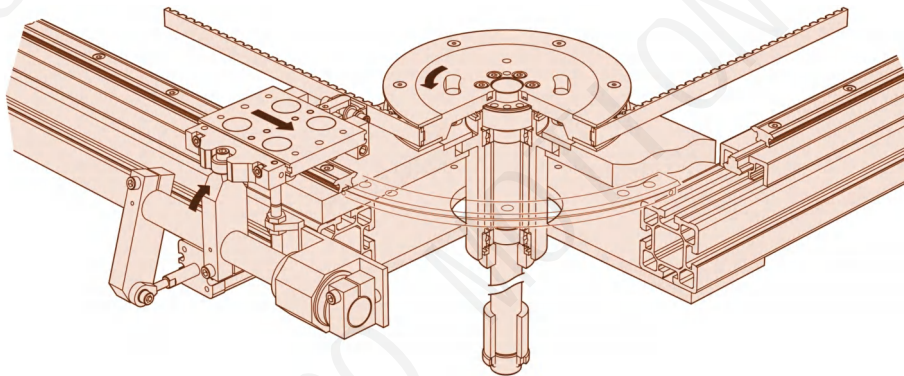

Fixed centre carriage 38-39

- The economic choice for rings and unidirectional track systems.
- Optional lubricators for increased load & life.
- Keyway facility in side faces for location of ancillary components.
- Supplied with fopped holes for ease of component mounting.
- Accurate overall height.
- Corrosion resistant version available.
- Clamping brake version for ring systems. See illustration left.
- Compatible with track system drive components and carriage locking system,

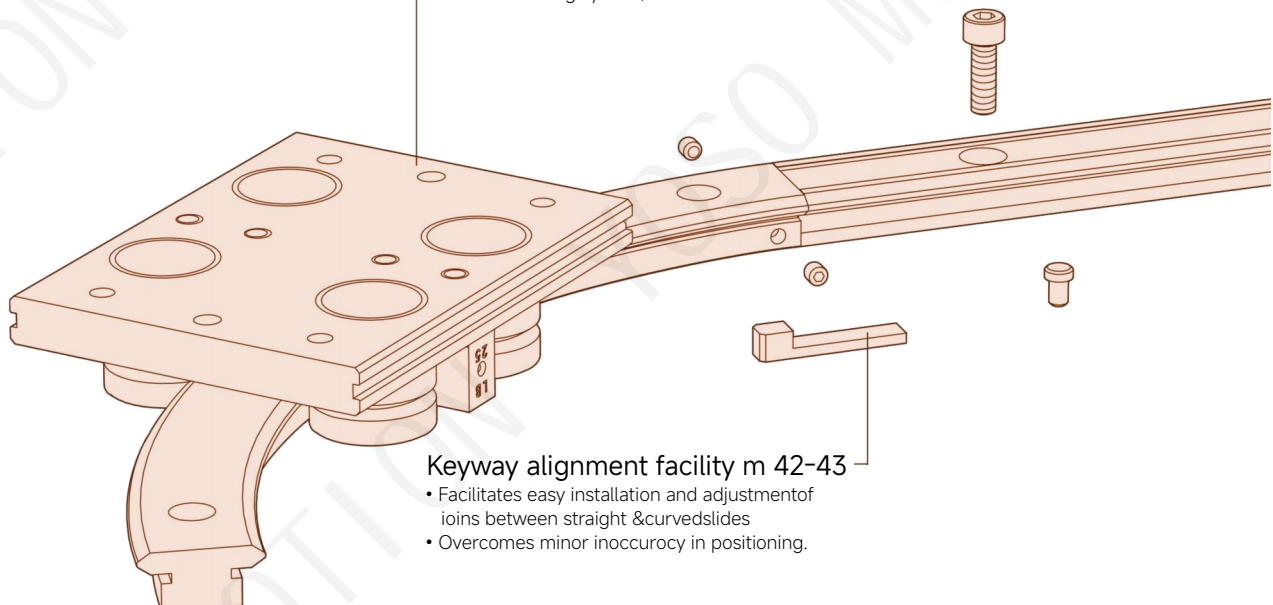

Keyway alignment facility m 42-43

- Facilitates easy installation and adjustment of joins between straight & curved slides
- Overcomes minor inaccuracy in positioning.

■ System Composition

● Tracksystem straight slides 42-43/Track system curved segments 44*

- *Ground dotum faces for location purposes.
- *Soft centre allows customising
- *Precision ground on ends and all important foces.
- *Stainless steel option.
- *All segments and slides precision matched.
- *Ground dotum faces for location purposes.
- *Option available to suit pre-drilled mounting holes.
- *90°and 180°segments available fromstock.
- *Any length segment available to order.
- Central keyway for location and alignment.
- Up to 4m in one piece,unlimited length achieved by butting.

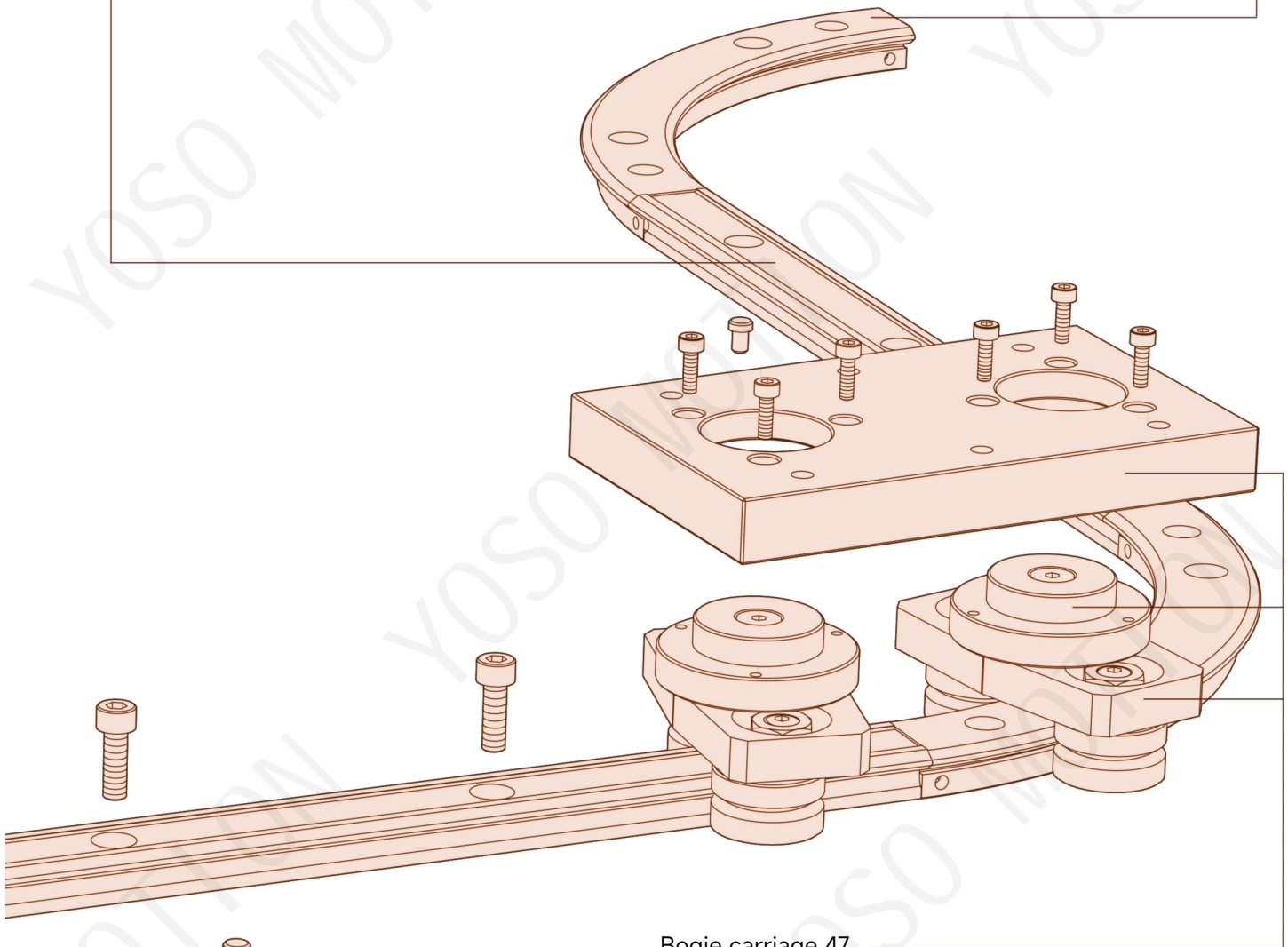

Dowel pins 42-43

- Locates in central keyway of straight slide for ease of location and alignment.

Bogie carriage 47

- Negotiates 'S'bends and differing bend radi.
- High performance swivel bearing for precision movement and extreme rigidity.
- Swivel bearingsore lubricated for life internally.
- Available in three sizes to suit 25,44&76 track systems.
- Supplied with tapped holes for ease of component mounting.
- Accurate overall height.
- large platform for mounting purposes.

■ V-rail HVR25C straight rail products

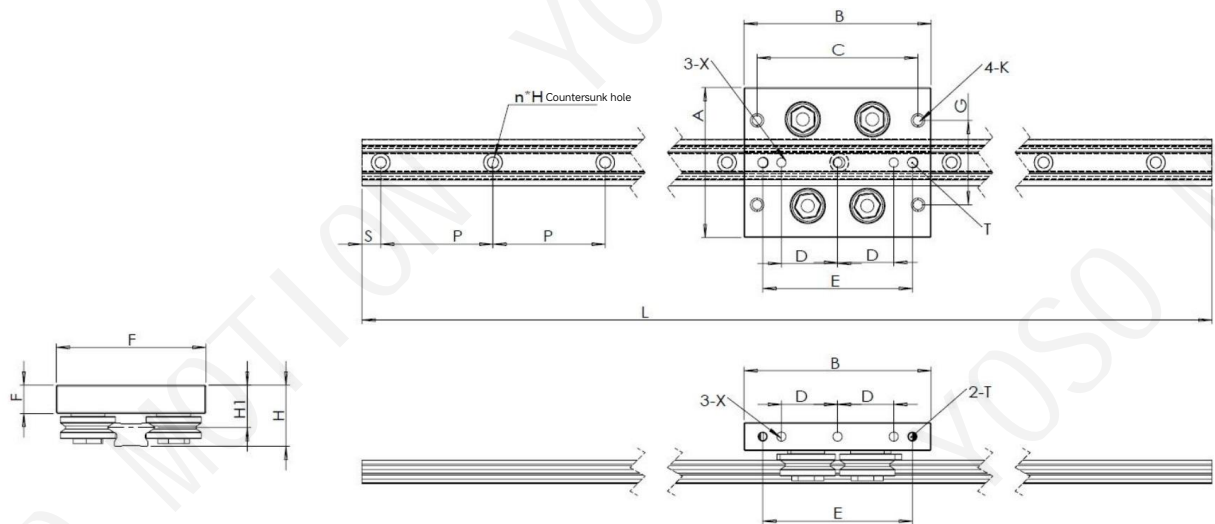

Component Specifications HVR25C	Main dimensions															
	A	B	C	D	E	F	G	S	P	L	H	H1	4-K	3-X	2-T	n*HSpigot
HVR25C Straight Track	80	100	86	30	80	15	45	End distan	60	4M	35.4	22.6	M6	φ5	M6	M6

■ V-Ring Rail Model HVR25C Product Drawing

The V-shaped working surface is hardened and has excellent wear resistance. The guide rail is precision ground by CNC grinder. The guide rail base has no hardness and can be machined. Three sizes are available, and the guide rail can be extended to any length by docking.

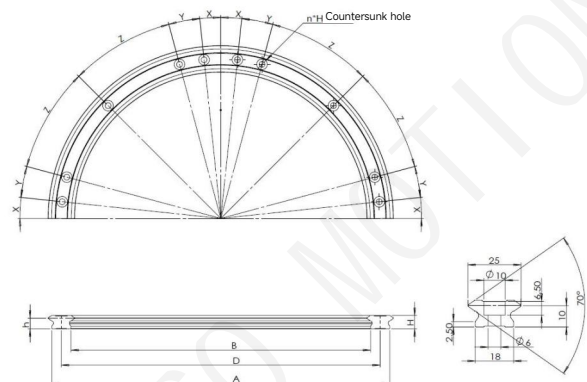

Component Specifications HVR25C	Main dimensions											
	B	D	A	h	H	R			X	Y	Z	n*HSpigot
HVR25C-200	175	200	225	10	12.5	90°	180°	360°	6	9	30	10*M5
HVR25C-255	230	255	280									
HVR25C-300	275	300	325									
HVR25C-351	326	351	376									
HVR25C-400	375	400	425									

V-rail HVR44C products

The V-shaped working surface is hardened and has very good wear resistance. The guide rail is precisely ground by a CNC guide rail grinder. The guide rail base has no hardness and can be processed. There are three sizes to choose from. The guide rail can be extended to any length by docking.

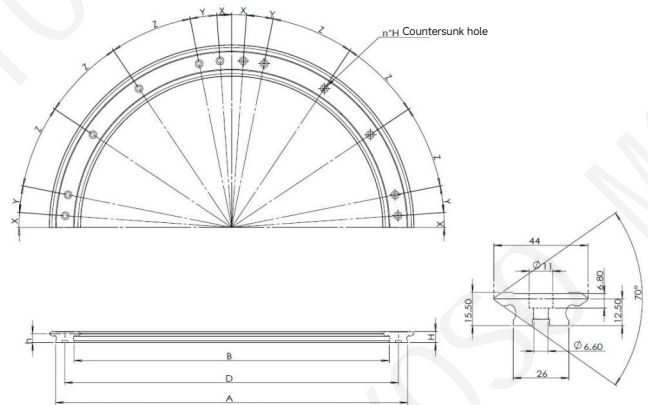

Component Specifications HVR44C	Main dimensions											
	B	D	A	h	H		R		X	Y	Z	n*HSpigot
HVR44C-468	442	468	494	12.5	15.5	90°	180°	360°	4	7.25	22.5	M6
HVR44C-612	586	612	638									

V-rail HVR44C straight rail products

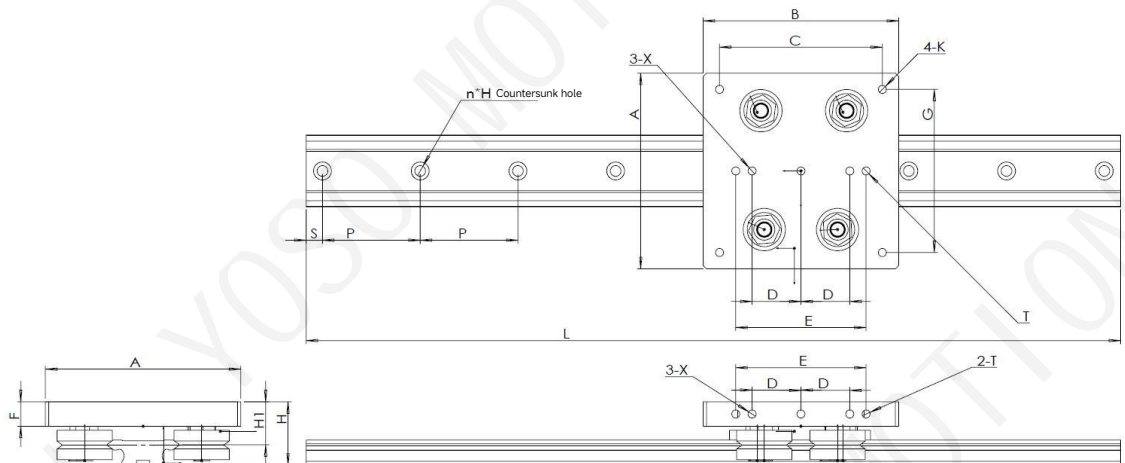

Component Specifications HVR44C	Main dimensions															
	A	B	C	D	E	F	G	S	P	L	H	H1	4-K	3-X	2-T	n*HSpigot
HVR44C Straight Track	120	120	100	30	80	15	100	End distan	60 ce	4M	38.9	26.4	M6	φ5	M6	M6

■ V-rail HVR50C products

The V-shaped working surface is hardened and has very good wear resistance. The guide rails are precisely ground by CNC grinders. The guide rail base has no hardness and can be machined. There are three sizes to choose from. The guide rails can be extended to any length by docking.

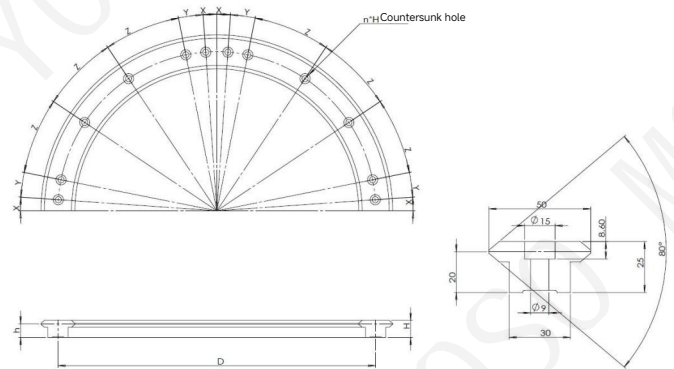

Component Specifications HVR50C	Main dimensions									
	D	h	H	R			X	Y	Z	n*HSpigot
HVR50C-468	468	20	25	90°	180°	360°	4	7.25	22.5	M8
HVR50C-600	600	20	25	90°	180°	360°	3	8.25	22.5	M8
HVR50C-800	800	20	25	90°	180°	360°	3	8.25	22.5	M8

■ V-rail HVR50C straight rail products

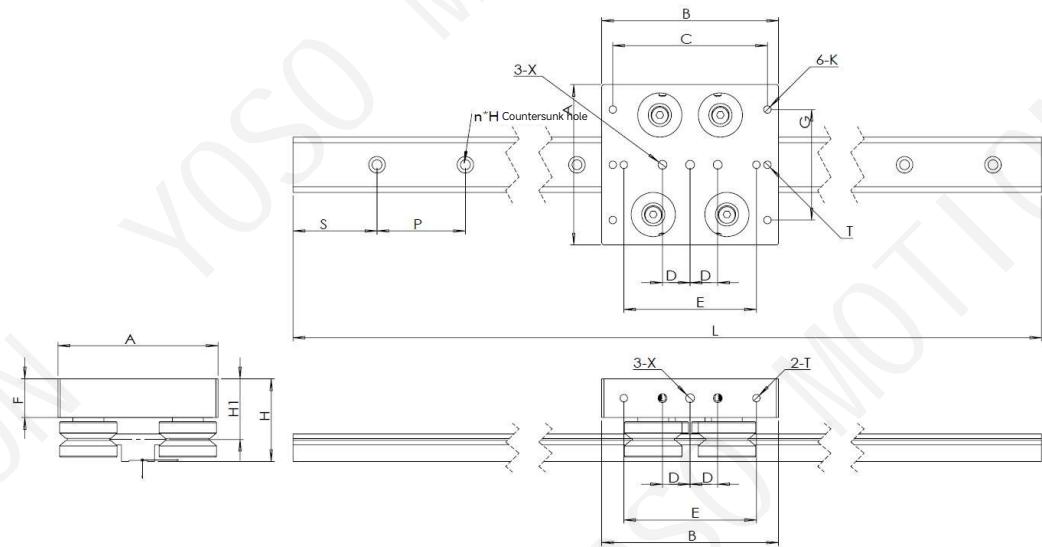

Component Specification HVR50C	Main dimensions															
	A	B	C	D	E	F	G	S	P	L	H	H1	4-K	3-X	2-T	n*HSpigot
HVR50C Straight Track	145	160	140	25	120	35	100	End distan	60 ce	4M	38.9	26.4	M8	φ8	M8	M8

V-rail HVR76C products

The V-shaped working surface is hardened and has very good wear resistance. The guide rails are precisely ground by CNC grinders. The guide rail base has no hardness and can be machined. There are three sizes to choose from. The guide rails can be extended to any length by docking.

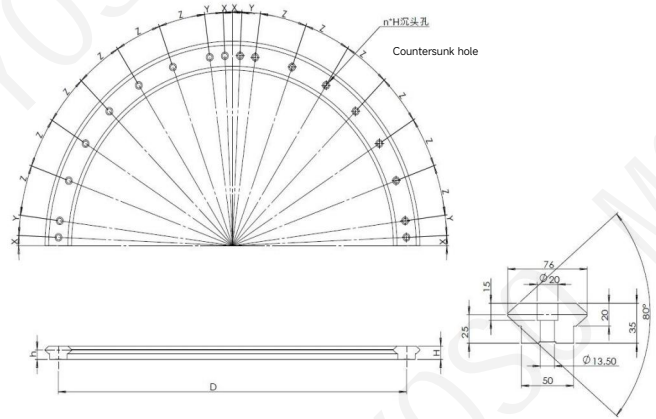

Component Specifications HVR76C	Main dimensions									
	D	h	H	R			X	Y	Z	n*HSpigot
HVR76C-1000	1000									M12
HVR76C-1033	1033	25	35	90°	180°	360°	12.5	12.5	12.5	M12
HVR76C-1267	1267	25	35	90°	180°	360°	2.5	5	12.5	M12
HVR76C-1501	1501									M12

V-rail HVR76C straight rail products

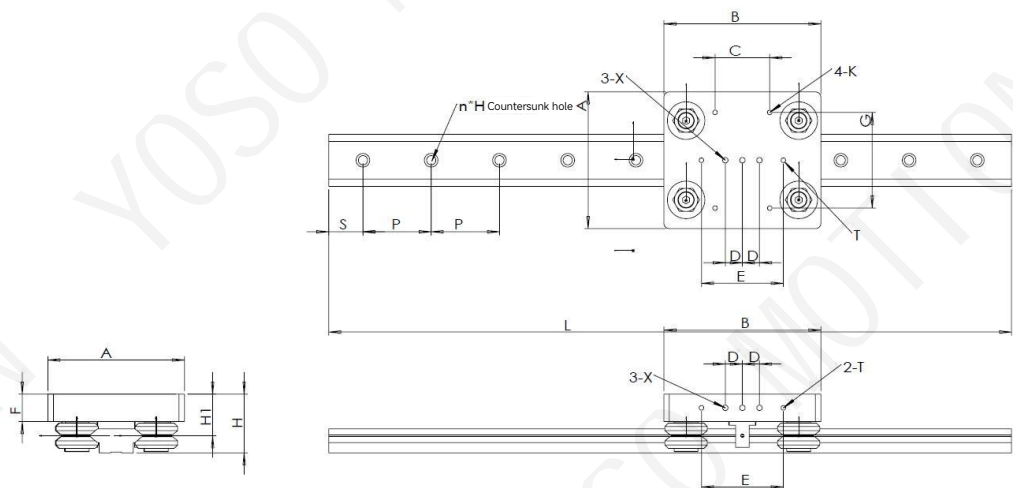

Component Specifications HVR76C	Main dimensions															
	A	B	C	D	E	F	G	S	P	L	H	H1	4-K	3-X	2-T	n*HSpigot
HVR76C Straight Track	200	230	80	25	120	40	140	End distance	100	4M	85.8	60.8	M8	φ8	M8	M12

■ V-rail HVR76C dimension series table (rectangular)

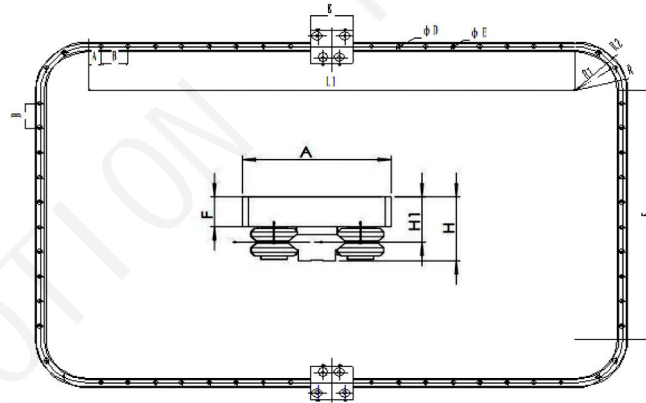

HVR - RS - 44 - A15 - R306 - 2300XL + 1600YL

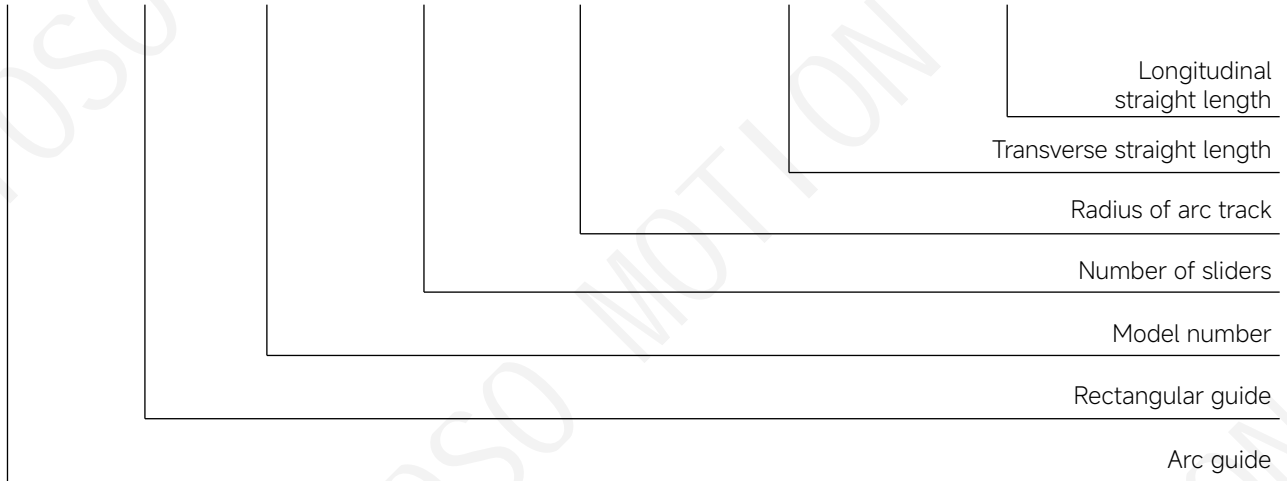

■ V-rail dimension series table (ellipse)

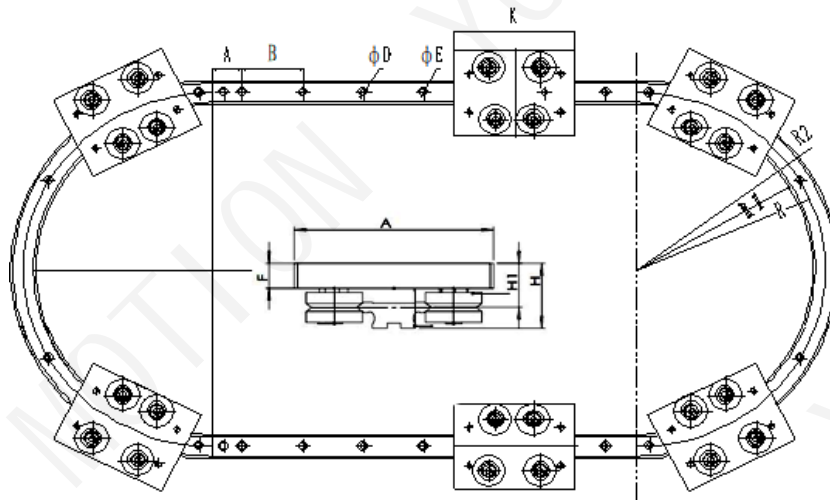

HVR - ES - 44 - A15 - R306 - 2300XL

Transverse straight length

Radius of arc track

Number of sliders

Model number

Circular guide rail

Arc guide

■ YCR rolling arc guide

Rolling arc guide is derived from YGH precision ball linear guide. On the premise of inheriting many advantages of YGH, it can realize the circular motion of arc objects of any diameter, overcoming the size limitation brought by the processing of bearings or rolling bearings. In theory, the larger the diameter of YCR arc guide, the more convenient it is to design, manufacture, install and maintain. Moreover, due to the unique mechanism design of YCR, it can achieve no gap and heavy load.

● Application

Large turntable, control device, medical device, stage device, vertical lathe

● Naming rules and meaning

Large turntable, control device, medical device, stage device, vertical lathe

YCR25A 2 UU C1 +60 /1000R H 6 T

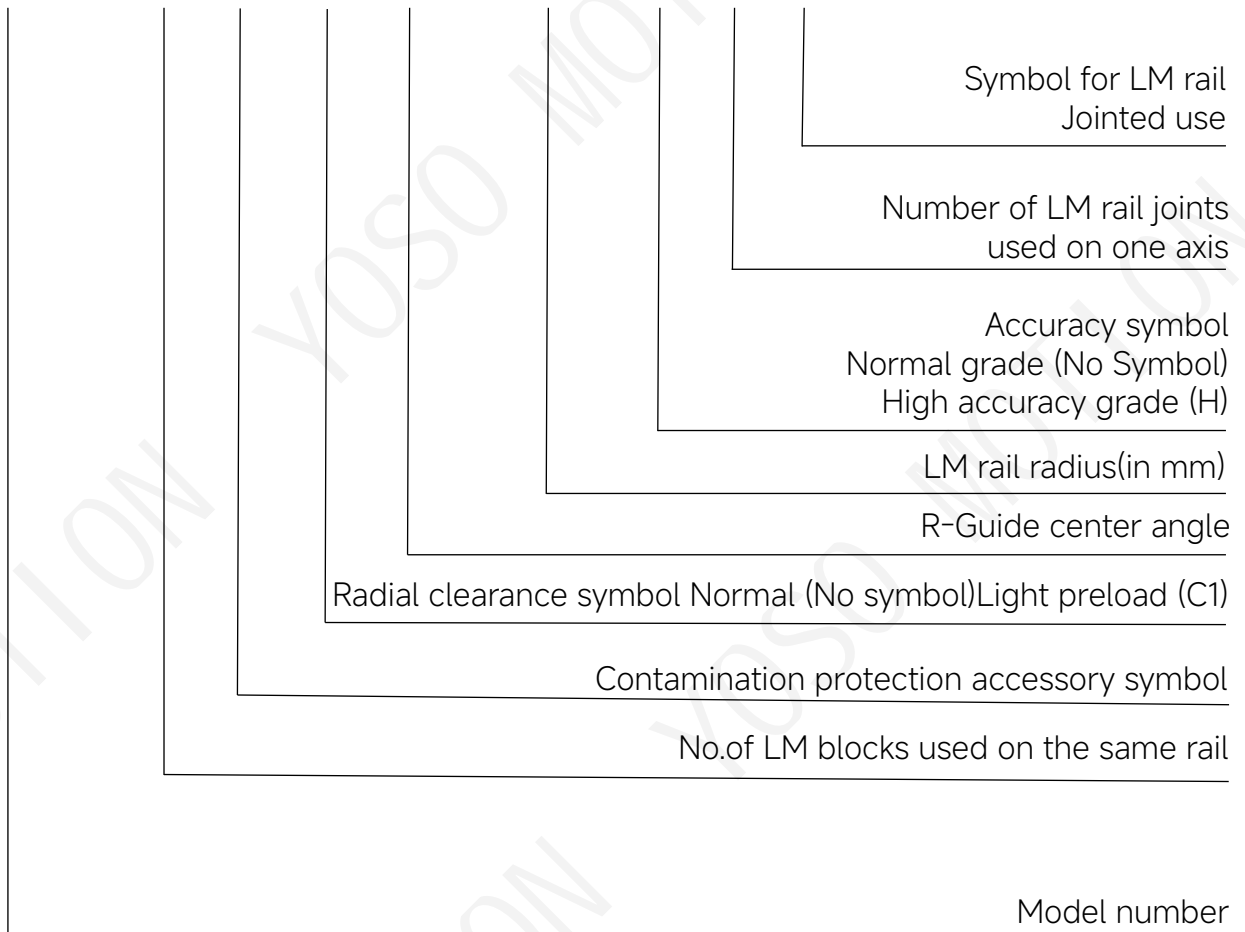

● Accuracy class

No.	diagram	Inspection items	Tolerance		
1		Parallelism between the center of the top surface of the slider and the reference ground of the guide rail	Arc length of guide rail	Accuracy class	
				4	5
			≤250	0.015	0.035
			>250~500	0.025	0.055
			>500~1000	0.035	0.07
			>1000~1500	0.04	0.08
>1500~2000	0.045	0.09			
2		Limit deviation of height H between the top surface of the slider and the reference ground of the guide rail	Accuracy class		
			4	5	
			±0.06	±0.10	
3		Variation of height H of top surface of multiple sliders on the same plane	Accuracy class		
			4	5	
			0.02	0.03	

● Type of preload

Indication mark	Ordinary	General preload
Model	Unmarked	C1
YCR12	-3~+3	-6~-2
YCR15	-4~+2	-12~-4
YCR25	-6~+3	-16~-6
YCR35	-8~+4	-22~-8
YCR45	-10~+5	-25~-10
YCR65	-14~+7	-32~-14

● R Guide Model YCR

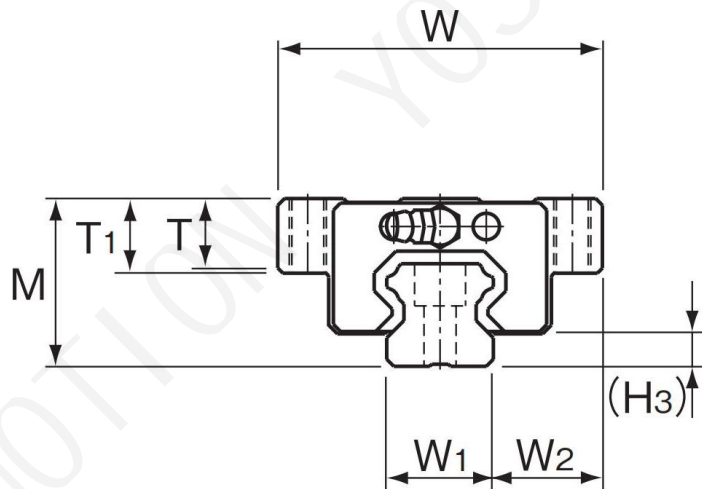

Model No.	Outer dimensions			LM block dimensions									Height H3
	Height M	Width W	Length L	B	C	S	L1	T	T1	N	E	Grease Nipple	
YCR12A+60/100R	18	39	44.6	32	18	M4	30.5	4.5	5	3.4	3.5	PB107	3.1
YCR15A+60/150R	24	47	54.5	38	24	M5	38.8	10.3	11	4.5	5.5	PB1021B	4.8
YCR15A+60/300R			55.5		28								
YCR15A+60/400R			55.8		28								
YCR25A+60/500R	36	70	81.6	57	45	M8	59.5	14.9	16	6	12	B-M6F	7
YCR25A+60/750R			82.3										
YCR25A+60/1000R			82.5										
YCR35A+60/600R	48	100	107.2	82	58	M10	80.4	19.9	21	8	12	B-M6F	8.5
YCR35A+60/800R			107.5										
YCR35A+60/1000R			108.2										
YCR35A+60/1300R			108.5										
YCR45A+60/800R	60	120	136.7	100	70	M12	98	23.9	25	10	16	B-PT1/8	11.5
YCR45A+60/1000R			137.3										
YCR45A+60/1200R			137.3										
YCR45A+60/1600R			138										
YCR65A+60/1000R	90	170	193.8	142	106	M16	147	34.9	37	19	16	B-PT1/8	15
YCR65A+60/1500R			195.4										
YCR65A+45/2000R			195.9										
YCR65A+45/2500R			196.5										
YCR65A+30/3000R			196.5										

● R Guide Model YCR

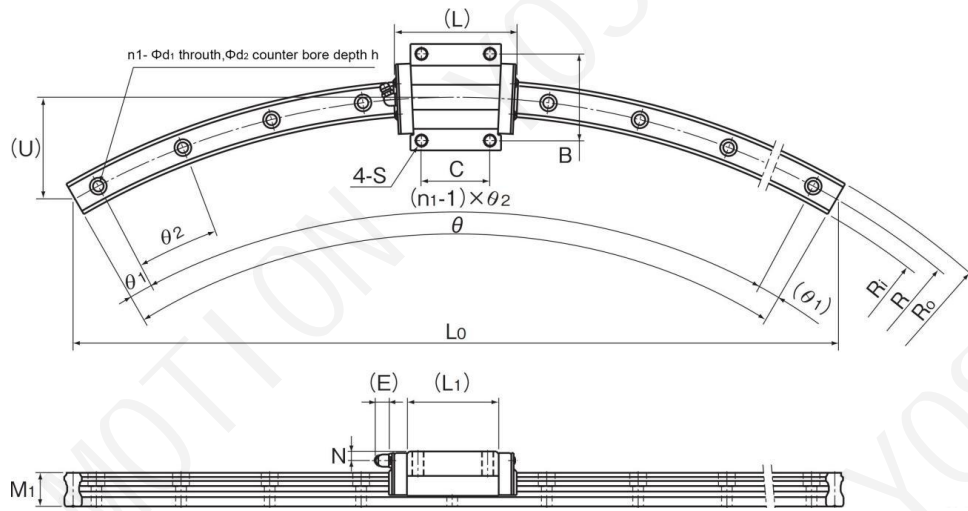

LM block dimensions										Basic load rating		Static permissible moment kN · m				Mass						
R	R0	Ri	L0	U	Width W1	W2	Height M1	d1x2xh	n1	θ°	θ1°	θ2°	C kN	C0 kN	MA		MB		MC MA	LM Block kg	LM Rail kg/m	
															1 Block	Double Blocks	1 Block	Double Blocks				
100	106	94	100	134	12	13.5	11	3.5X6X5	3	60	7	23	4.7	8.53	0.0409	0.228	0.0409	0.228	0.0445	0.08	0.83	
150	157.5	142.5	150	201	15	16	15	4.5x7.5x5.3	3	60	7	23	6.66	10.8	0.0805	0.457	0.0805	0.457	0.0844	0.2	1.5	
300	307.5	292.5	300	40					5		6	12	8.33	13.5								
400	407.5	392.5	400	54					7		3	9	8.33	13.5								
500	511.5	488.5	500	67	23	23.5	22	7x11x19	9	60	2	7	199	34.4	0.307	1.71	0.307	1.71	0.344	0.59	3.3	
750	761.5	738.5	750	100					12		2.5	5										
1000	1011.5	988.5	1000	134					15		2	4										
600	617	583	600	80	34	33	29	9x14x12	7	60	3	9	373	61.1	0.782	3.93	0.782	3.93	0.905	1.6	6.6	
800	817	793	800	107					11		2.5	5.5										
1000	1017	983	1000	134					12		2.5	5										
1300	1317	1283	1300	174					17		2	3.5										
800	822.5	777.5	800	107	45	37.5	38	14x20x17	8	60	2	8	60	95.6	1.42	7.92	1.42	7.92	1.83	2.8	11.0	
1000	1022.5	977.5	1000	134					10		3	6										
1200	1222.5	1177.5	1200	161					12		2.5	5										
1600	1622.5	1577.5	1600	214					15		2	4										
1000	1031.5	968.5	1000	134	63	53.5	53	18X26X22	8	45	2	8	141	215	4.8	23.5	4.8	23.5	5.82	8.5	22.5	
1500	1531.5	1468.5	1500	201					10		60	3										6
2000	2031.5	1968.5	1531	152					12		45	0.5										4
2500	2531.5	2468.5	1913	190					13		45	1.5										3.5
3000	3031.5	2968.5	1553	102					10		30	1.5										3

■ FDA rolling arc guide

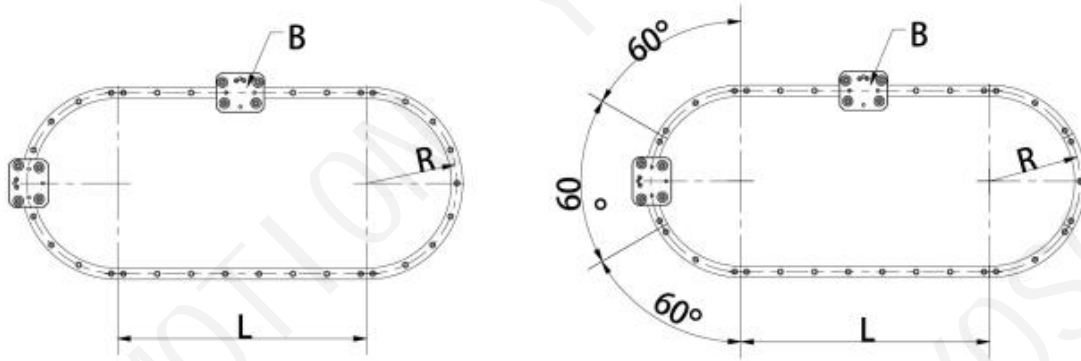

FDA 20RV - G3 - 180 (2) - 2B - 300R - 1000 (2) - S(1) - C(1) - D(1)

	Chain connection parts (quantity)
	Precision positioning tools (quantity)
	Industrial belt connector (quantity)
	Number of linear guides
	Linear guide length
	Arc radius
	Lubrication quantity
	Arc Degree
	Arc Angle
	Components G1/G3/G8
	Curved rail specifications
	Rail shape

■ FDA rolling arc guide

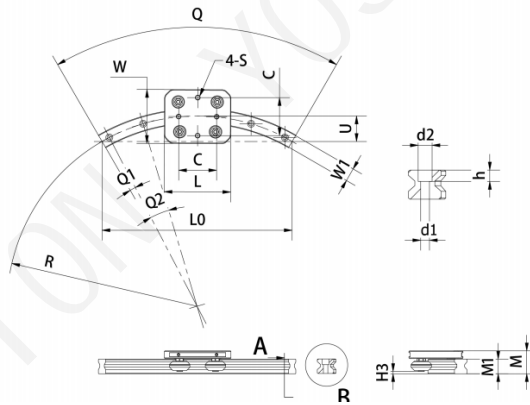

Nominal Model	FDA25RV+60(Arc Guide Parameters)										
	W1	M1	Q	Q1	Q2	L0	U	d1xd2xh	C(kN)	Co(kN)	Weight kg
FDA25RV+60/100R	23	23	60	8	22.0	100	13.4	7x11x9	4.8	2.03	
FDA25RV+60/150R				6	24.0	150	20.1				
FDA25RV+60/200R				4.5	17.0	200	26.8				
FDA25RV+60/250R				3	13.5	250	33.5				
FDA25RV+60/300R				2.5	11.0	300	40.2				
FDA25RV+60/350R				3	9.0	350	46.9				
FDA25RV+60/400R				2.1	9.3	400	53.6				
FDA25RV+60/450R				2	8.0	450	60.3				
FDA25RV+60/500R				1.6	7.1	500	67				
FDA25RV+60/550R				1.2	6.4	550	73.7				
FDA25RV+60/600R				1	5.8	600	80.4				
FDA25RV+60/650R				1	5.8	650	87.08				
FDA25RV+60/700R				1.2	4.8	700	93.8				
FDA25RV+60/750R				1.2	4.8	750	100.5				
FDA25RV+60/1000R				1.2	3.6	1000	134				
FDA25RV+60/1200R				0.55	2.9	1200	160.8				
FDA25RV+60/1250R				1	2.9	1250	167.5				
FDA25RV+60/1300R				0.55	3.1	1300	174				
FDA25RV+60/1400R				0.6	2.45	1400	188				
FDA25RV+60/1450R				0.6	2.45	1450	194.3				
FDA25RV+60/1850R	0.48	2.46	1850	247.9							
FDA25RV+60/2000R	0.60	2.10	2000	268							
FDA25RV+60/2500R	0.50	1.55	2500	335							
FDA25RV+60/3000R	0.40	1.20	3000	401.9							

Nominal Model	M	H3	W	L	B	C	4-S	d1xd2xh	C(kN)	Co(kN)	Weight kg
FDA25RV+60/R	36	3.88	85	105	60	60	M8	7x11x9	4.8	2.03	
All specifications are the same size											

■ FDA rolling arc guide

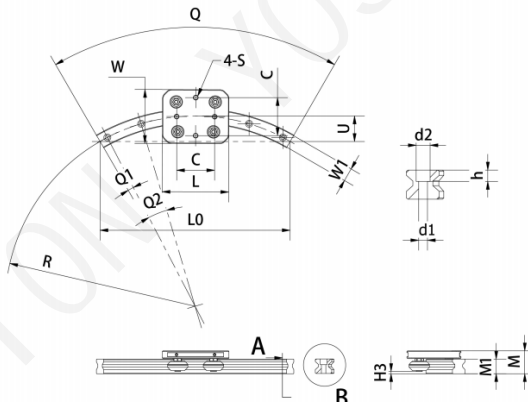

Nominal Model	FDA25RV+60(Arc Guide Parameters)										
	W1	M1	Q	Q1	Q2	L0	U	d1xd2xh	C(kN)	Co(kN)	Weight kg
FDA25RV+90/100R	23	23	90	8.00	37.0	141	29.3	7x11x9	4.8	2.03	
FDA25RV+90/150R				6.00	26.0	212	43.9				
FDA25RV+90/175R				4.00	20.5	248	51.3				
FDA25RV+90/200R				3.50	16.6	283	58.6				
FDA25RV+90/250R				3.60	13.8	354	73.2				
FDA25RV+90/300R				3.00	12.0	424	87.9				
FDA25RV+90/350R				2.70	9.4	495	103				
FDA25RV+90/400R				2.00	8.6	566	117.2				
FDA25RV+90/500R				1.80	7.2	707	146.4				
FDA25RV+90/550R				1.45	6.7	777.8	161.1				
FDA25RV+90/600R				1.50	5.8	846	175.7				
FDA25RV+90/700R				1.45	6.7	989.9	205				
FDA25RV+90/750R				1.30	4.6	1060.7	219.7				
FDA25RV+90/860R				1.00	4.0	1216.2	251.9				
FDA25RV+90/900R				1.00	4.0	1272.8	263.6				
FDA25RV+90/1000R				0.80	3.4	1414.2	292.9				
FDA25RV+90/1513R				0.6	2.96	2139.7	443.1				
FDA25RV+90/2000R	0.35	2.35	2828.4	585.8							
FDA25RV+90/3000R	0.3	1.49	4242.6	878.7							

Nominal Model	M	H3	W	L	B	C	4-S	d1xd2xh	C(kN)	Co(kN)	Weight kg
FDA25RV+90/R	36	3.88	85	105	60	60	M8	7x11x9	4.8	2.03	
All specifications are the same size											

■ FDA rolling arc guide

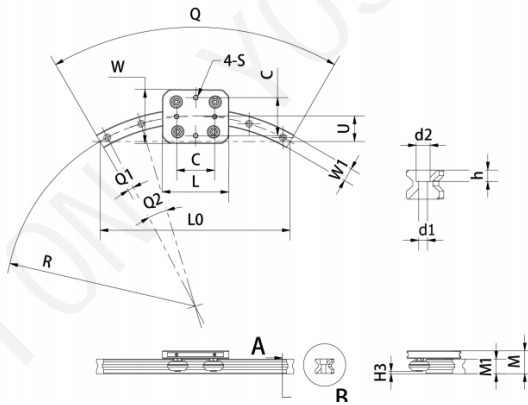

Nominal Model	FDA25RV+60(Arc Guide Parameters)										
	W1	M1	Q	Q1	Q2	L0	U	d1xd2xh	C(kN)	Co(kN)	Weight kg
FDA25RV+180/75R	23	23	60	10	35.0	150	75	7x11x9	4.8	2.03	
FDA25RV+180/80R				8	37.0	160	80				
FDA25RV+180/100R				6	26.0	200	100				
FDA25RV+180/125R				7.5	27.5	250	125				
FDA25RV+180/150R				4	20.5	300	150				
FDA25RV+180/160R				6	21.0	320	160				
FDA25RV+180/175R				3.5	16.6	350	175				
FDA25RV+180/175.5R				4.5	21.3	350	175				
FDA25RV+180/200R				3.6	13.8	400	200				
FDA25RV+180/250R				3	12.0	500	250				
FDA25RV+180/300R				2.7	9.4	600	300				
FDA25RV+180/310R				4	17.2	620	310				
FDA25RV+180/350R				2	8.6	700	350				
FDA25RV+180/355R				2.7	9.7	710	355				
FDA25RV+180/351R				2.7	9.7	702	351				
FDA25RV+180/400R				2	8.8	800	400				
FDA25RV+180/500R				2	8.0	1000	500				
FDA25RV+180/550R				1.8	8.4	1100	550				
FDA25RV+180/580R				1.5	5.9	1160	580				
FDA25RV+180/600R				1.5	5.9	1200	600				
FDA25RV+180/700R	1.17	6.6	1400	700							
FDA25RV+180/750R	2.6	4.6	1500	750							
FDA25RV+180/800R	1.2	4.8	1600	800							
FDA25RV+180/900R	0.7	3.8	1800	900							
FDA25RV+180/1000R	0.75	3.5	2000	1000							

Nominal Model	M	H3	W	L	B	C	4-S	d1xd2xh	C(kN)	Co(kN)	Weight kg
FDA25RV+180/R	36	3.88	85	105	60	60	M8	7x11x9	4.8	2.03	
All specifications are the same size											

LM Guide Straight-Curved Guide Model YS-HMG

The Straight Curved Guide YS-HMG is a new straight curved guide that combines the technologies of the LM Guide YGH and R Guide YCR to enable the same type of LM slider to move continuously on straight and curved tracks. It has achieved significant cost reduction by improving the work efficiency of assembly and conveyor lines and inspection equipment, and simplifying the structure by eliminating lifts and workbenches.

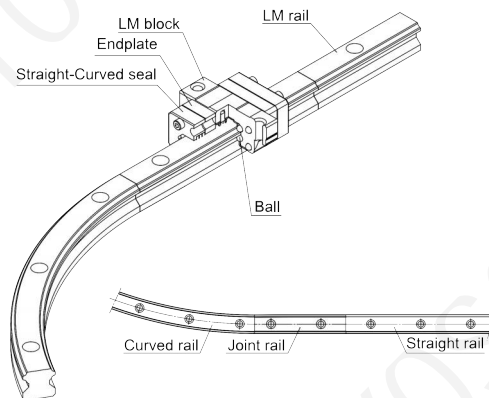

Straight Curved Guide YS-HMG When using 2 or more rails, or when connecting 2 or more LM blocks to one rail, a rotation mechanism or a slide mechanism is required to rotate the table around the curved portion. See Figure 4 for an example of such a mechanism.

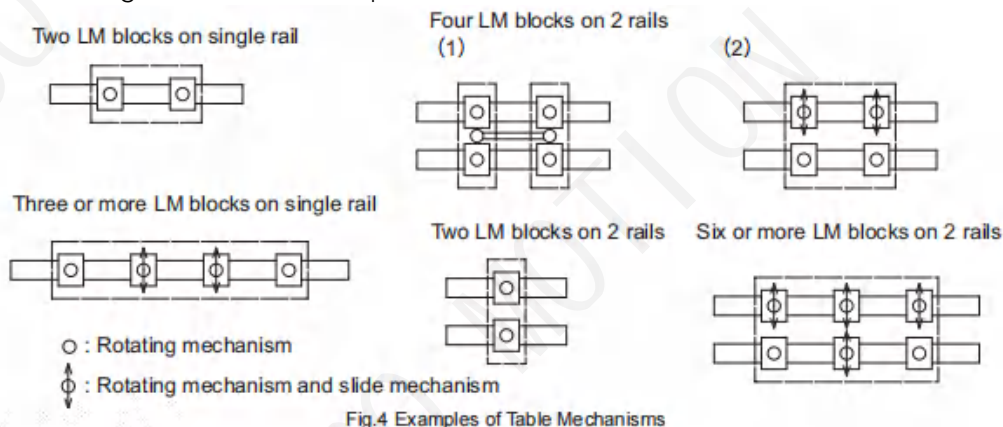

Fig.4 Examples of Table Mechanisms

Figure 5 shows an example of the design of a table when using a unit on multiple axes. The YS-HMG requires a rotating mechanism and a sliding mechanism because the table becomes eccentric when the LM block transitions from a straight segment to a curved segment. The amount of eccentricity varies depending on the radius of the curved segment and the span of the LM block. Therefore, it is necessary to design the system according to the corresponding specifications. Figure 6 shows a detailed diagram of the sliding and rotating mechanisms. In the figure, an LM guide is used in the sliding mechanism and a cross roller ring is used in the rotating mechanism to achieve smooth sliding and rotating motion.

For driving the Straight-Curved Guide, belt drives and chain drives are available.

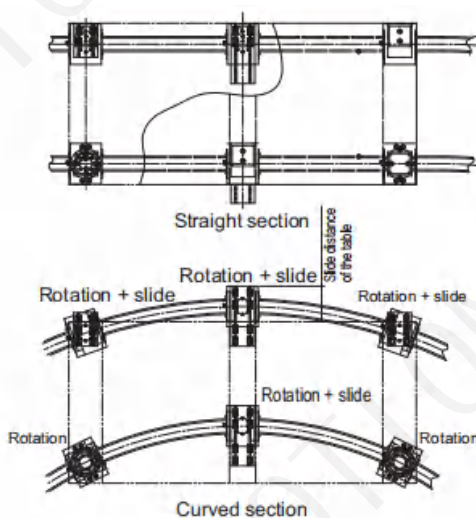

Fig.5

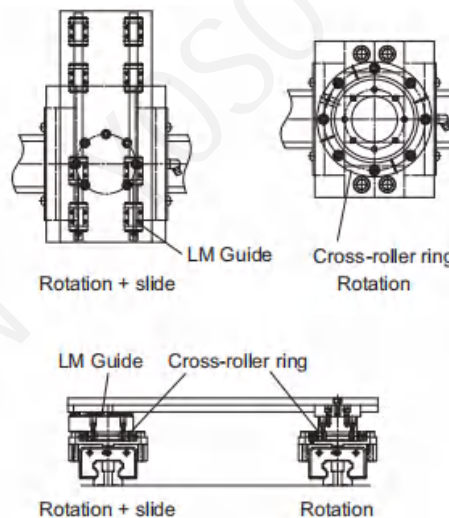
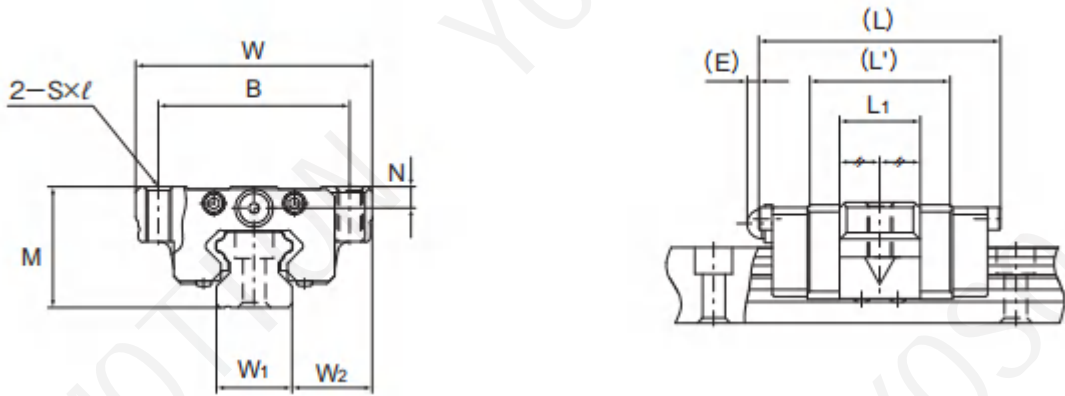

Fig.6

● Model YS-HMG



Model No.	Outer dimensions				LM block dimensions					LM rail dimensions			
	M	W	L	L'	B	Sxℓ	L ₁	N	E	Straight rail			Height M ₁
										W ₁	W ₂	F	
YS-HMG 15A	24	47	48	28.8	38	M5x11	16	4.3	5.5	15	16	60	15
YS-HMG 25A	36	70	62.2	42.2	57	M8x16	25.6	6	12	23	23.5	60	22
YS-HMG 35A	48	100	80.6	54.6	82	M10x21	32.6	8	12	34	33	80	29
YS-HMG 45A	60	120	107.6	76.6	100	M12x25	42.6	10	16	45	37.5	105	38
YS-HMG 65A	90	170	144.4	107.4	142	M16x37	63.4	19	16	63	53.5	150	53

● Model YS-HMG

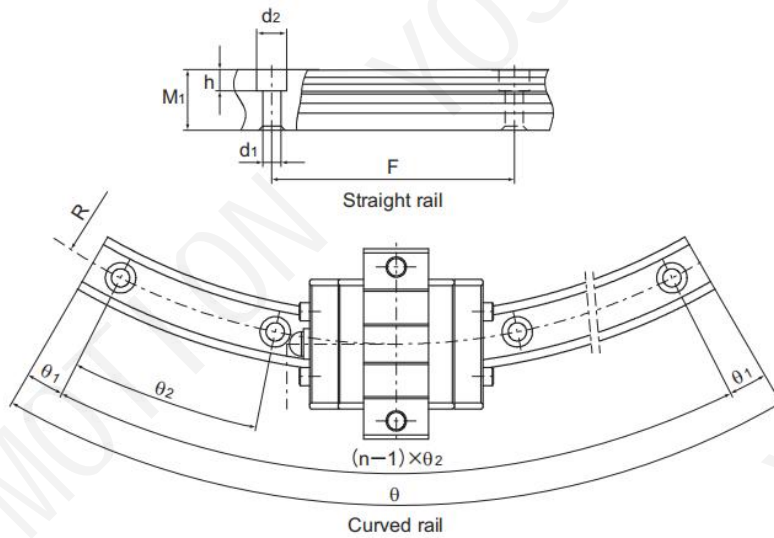

LM rail dimensions						Basic dynamic load rating (C)	Basic static load rating (Co)	
Mounting hole $d_1 \times d_2 \times h$	Curved rail						Resultant load (C)kN	Straight section (C_{0st})kN
	R	n	θ°	θ_1°	θ_2°			
4.5×7.5×5.3	150	3	60	7	23	2.56	4.23	0.44
	300	5	60	6	12			
	400	7	60	3	9			
7×11×9	500	9	60	2	7	9.41	10.8	6.7
	750	12	60	2.5	5			
	1000	15	60	2	4			
9×14×12	600	7	60	3	9	17.7	19	11.5
	800	11	60	2.5	5.5			
	1000	12	60	2.5	5			
	1300	17	60	2	3.5			
14×20×17	800	8	60	2	8	28.1	29.7	18.2
	1000	10	60	3	6			
	1200	12	60	2.5	5			
	1600	15	60	2	4			
18×26×22	1000	8	60	2	8	66.2	66.7	36.2
	1500	10	60	3	6			
	2000	12	45	0.5	4			
	2500	13	45	1.5	3.5			
	3000	10	30	1.5	3			

Table1 Static Permissible Moments of Model YS-HMG

Model No.	M_A		M_B		M_C	
	Straight section	Curved section	Straight section	Curved section	Straight section	Curved section
YS-HMG 15	0.008	0.007	0.008	0.01	0.027	0.003
YS-HMG 25	0.1	0.04	0.1	0.05	0.11	0.07
YS-HMG 35	0.22	0.11	0.22	0.12	0.29	0.17
YS-HMG 45	0.48	0.2	0.48	0.22	0.58	0.34
YS-HMG 65	1.47	0.66	1.47	0.73	1.83	0.94

Level Difference Specification for the Joint

The accuracy error of LM rail installation will affect the service life of the product. When installing LM rails, pay attention to control the height difference at the joint within the specification range shown in Table 2. For joints between curved rails and joints between curved sections and joint rails, it is recommended to use flushing pieces as shown in Figure 7. When using flushing pieces, place the fixed butt piece on the outside, push the rail toward the butt piece, and then turn the adjustment screw from the inside to adjust the height difference at the joint.

Table2 Level Difference Specification for the Joint

Model No.	Ball raceway, side face	Upper face	Maximum clearance of the joint section
15	0.01	0.02	0.6
25	0.01	0.02	0.7
35	0.01	0.02	1.0
45	0.01	0.02	1.3
65	0.01	0.02	1.3

Note) Place the pin on the outer circumference and the bolt on the inner circumference.

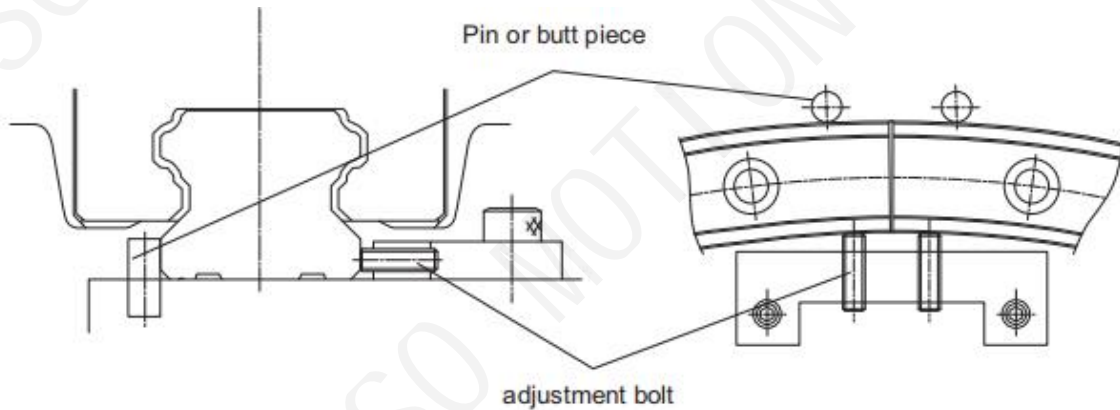

Fig.7 Flush piece

About the Curved Section

The curved portion of the YS-HMG model has a gap due to structural reasons. Therefore, this model may not be suitable for applications that require high-precision feeding. In addition, the curved portion cannot withstand large moments. When a large moment is applied, it is necessary to increase the number of LM blocks or LM rails.

Jointed LM Rail

The YS-HMG type always requires a connecting rail where the LM block travels from a straight section to a curved section and the curve reverses (e.g. S-curve). Please take this into consideration when designing your system.

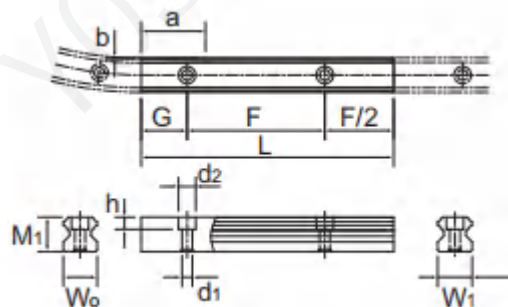

Table3 Dimension of the Jointed Rail

Model No.	Dimension of the jointed rail							
	Height	Pitch	Mounting hole	Width		Taper length	Taper depth	Radius
	M _i	F	d ₁ ×d ₂ ×h	W _i	W _o	a	b	R
15A	15	60	4.5×7.5×5.3	15	14.78	28	0.22	150
					14.89		0.11	300
					14.92		0.08	400
25A	22	60	7×11×9	23	22.83	42	0.17	500
					22.89		0.11	750
					22.92		0.08	1000
35A	29	80	9×14×12	34	33.77	54	0.23	600
					33.83		0.17	800
					33.86		0.14	1000
					33.9		0.1	1300
45A	38	105	14×20×17	45	44.71	76	0.29	800
					44.77		0.23	1000
					44.81		0.19	1200
					44.86		0.14	1600
65A	53	150	18×26×22	63	62.48	107	0.52	1000
					62.66		0.34	1500
					62.74		0.26	2000
					62.8		0.2	2500
					62.83		0.17	3000

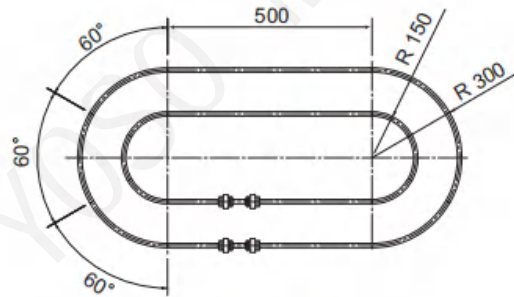

Fig.8 Example of model No.

■ Model number coding

YS-HMG15A 2 UU C1 +1000L T + 60/150R 6T + 60/300R 6T -II

Model number

No. of LM blocks used on the same rail

Contamination protection accessory symbol

Radial clearance symbol
Normal (No symbol) joint
Light preload (C1)

Overall linear LM rail length per rail

Symbol for linear LM rail joint

Center angle of one inner curved rail

Radius of inner curved rail

No. of inner curved LM rails jointed

Center angle of one outer curved rail

Radius of outer curved rail

No. of outer curved LM rails jointed

Symbol for No. of rails used on the same plane



YOSO German quality, Industrie 4.0 best platform



High speed



Heavy load



Precise

YOSO provides perfect solutions for various displacement control flexible control force drive control application scenarios

Jingpeng Machinery Equipment (Shanghai) Co., Ltd.

Contact information:

☎ Telephone: 0086-13636560152

📍 Room 123, Block B, Building 11, No. 1101, Hui Road, Jiading District, Shanghai

🌐 Website: www.yosomove.com



Whatsapp