

Ball Screw & Support Unit

High quality products from Germany

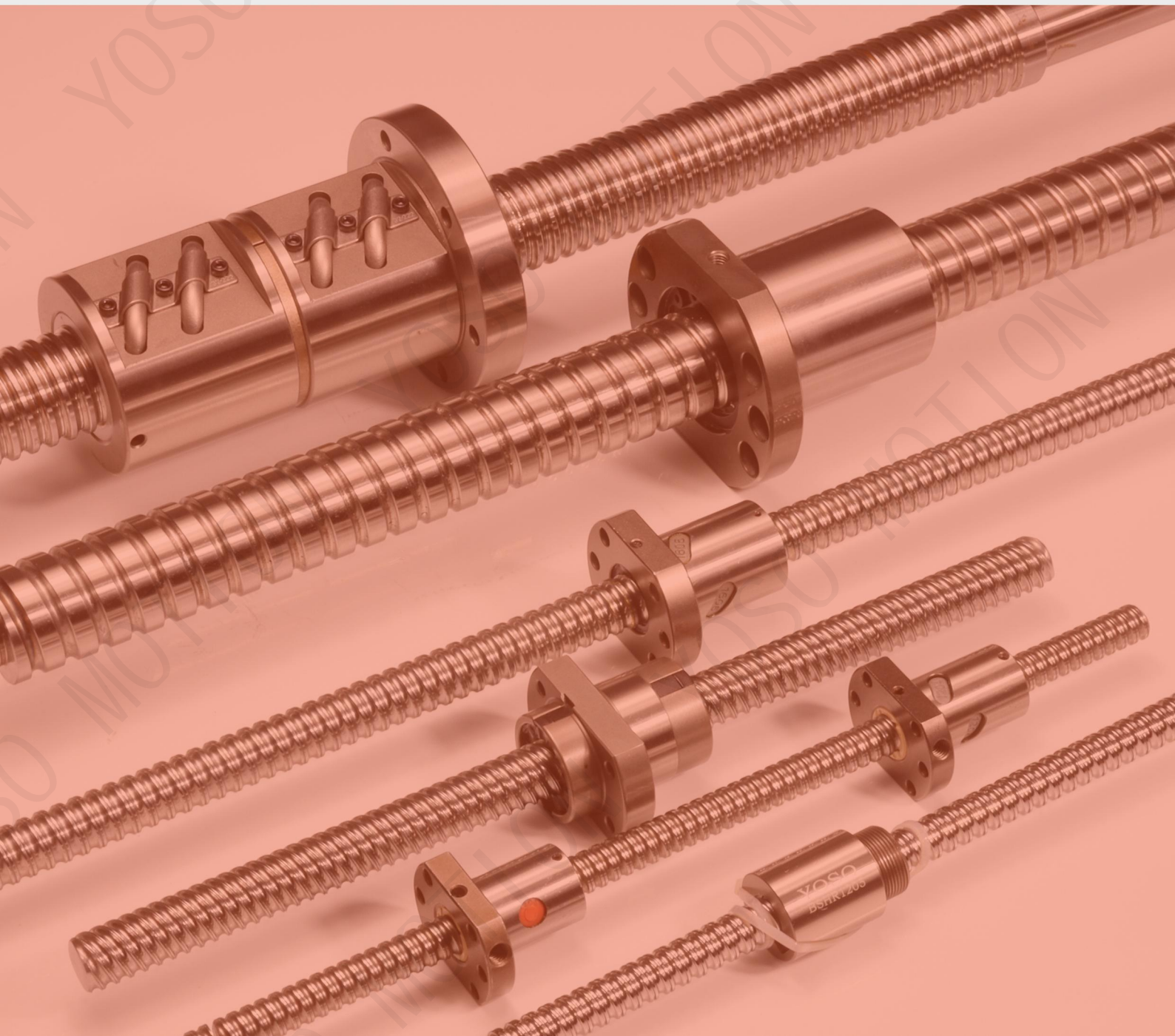

Ball Screw



1-1 Features of YOSO MOTION Ball Screw	C02
1-2 Ball Screw Selection Procedure	C04
1-3 Accuracy	C05
1-4 Screw Shaft Design	C11
1-5 Driving Torque	C17
1-6 NUteS	C19
1-7 Rigidity	C21
1-8 Positioning Accuracy	C24
1-9 Service Life Design	C26
1-10 Cautions About Use of Ball Screws	C32
2-1 Nominal Model Code of Ball Screw	C36
2-2 Precision Ground Ball Screw Series	C39
2-2-1 YOSO MOTION Nut of Precision Ground Ball Screw Type	C39
2-3 Rolled Ball Screw	C65
2-3-1 Rolled Screws	C65
2-3-2 The Features of YOSO MOTION Rolled Ball Screw	C65
2-3-3 Nomina Model Code of Rolled Ball Screws	C65
2-3-4 Preload of Rolled Ball Screw	C68
2-4 Rolled Ball Screw Seres	C69
2-4-1 YOSO MOTION Nut of Rolled Ball Screw Type	C69

Support unit



- SGS-C Disk/Clamp Type// Shorter Flexible Coupling.....D01
- SGL-C Disk/Clamp Type //Longer Flexible Coupling.....D03
- Motor Bracket MBCB 12/Motor Bracket MBCB 15.....D05
- Motor Bracket MBCE 10/12/Motor Bracket MBCF 10/12.....D07
- Votor Bracket /BCE 15.....D09
- Motor Bracket MBCA 15/20.....D10
- Motor Bracket MBCS 15/17/20/Motor Bracket MBCF20.....D13
- Motor Bracket MBC 25/30 /Motor Bracket MBCS25.....D15
- Recommended Shaft End Shape(Fixed side)for MBc Types.....D19
- Votor Bracket BA Series(Narrow Type).....D20
- Motor Bracket MBB Series(Hidden Type).....D21
- Motor Bracket MB Series(Low Narrow Type).....D22
- Motor Bracket MBH.....D23
- Support Unit HF Type(Rectangular Type).....D24
- Motor Bracket MB series and Corresponding Motor Reference Table.....D25
- Characteristic Values of(fixed-side)Support Units and Bearing.....D28
- Rectangular Support Unit AK Type(fixed-side)/AF series(supported-side).....D30
- Rectangular Support Unit BK Type(Fixed-side)/BF series(supported-side).....D34
- Rectangular Support Unit EK Type(Fixed-side)/EF series(supported-side).....D39
- Round Support Unit FK Type (fixed-side)/FF series(supported-side).....D44
- Round Support Unit FKA Type(Fixed-side).....D50
- Rectangular Low Profile Support Unit LK Type(Fixed-side).....D53
- Rectangular Low Profile Support Unit LF/ LFA type(supported-side).....D55
- Heavy Load Support Unit WBK Type.....D57
- Heavy Load Support Unit SBK Type.....D59
- Heavy Load Support Unit MBK Type (With Motor Bracket).....D61
- Standard Lock Nut/ Heavy Load Lock Nut.....D63
- Recommended Shaft End Shape for Fixed-side Support Unit.....D66
- Recommended Shaft End Shape for Supported-side Support Unit.....D68
- Recommended Shaft End Shape for Heavy Load Support Unit.....D69
- Support Unit Equivalent Interchangeable for Major Manufacture.....D70
- Nut Bracket /C/MGD Type.....D71

ABOUT BALL SCREW

1-1 Features of YOSO MOTION Ball Screw

(1) High Reliability

YOSO MOTION applies stringent quality control standards on every production process. With proper lubrication and use, trouble-free operation for an extended period of time is possible.

(2) Smooth Operation

The high efficiency of ball screw is vastly superior than conventional screws as shown in Fig 1.1.1. It takes less than 30% torque to make the linear motion into rotary motion.

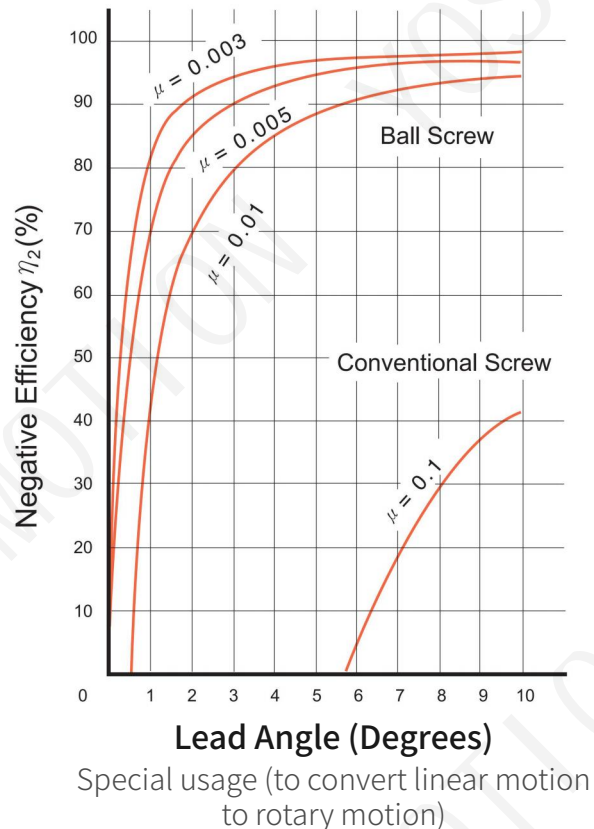
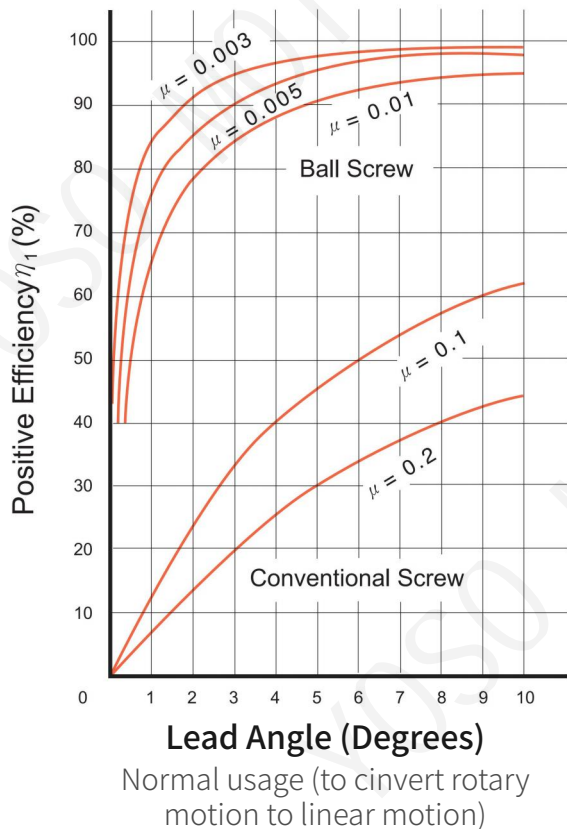

μ : friction coefficient

$$P = \frac{2\pi\eta_1 \times T}{\ell}$$

T = Torque kgf · cm
 P = Force kgf
 = Lead cm
 η_1 = Efficiency

$$T = \frac{\ell \times \eta_2 \times P}{2\pi}$$

T = Torque kgf · cm
 P = Force kgf
 = Lead cm
 η_2 = Efficiency

Fig 1.1.1 Mechanical Efficiency of Ball Screws

(3) High Rigidity and Preload

As figure 1.1.2 shown in below, the ball screw of YOSO MOTION is designed with Gothic arch groove, which makes the screw easy to rotate even using minimum axial play. To make the rigidity more appropriate to using condition, you can change the preload between one two screw nuts to reduce axial play.



Fig 1.1.2 Groove Shape of YOSO MOTION Precision Ball Screw

(4) Circulation Method

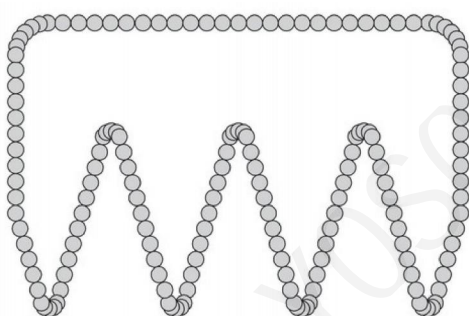

Fig 1.1.3 External Ball Circulation Nuts

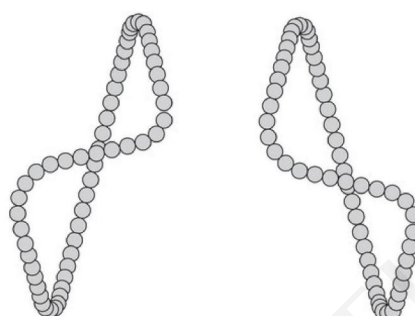

Fig 1.1.4 Internal Ball Circulation Nuts

(5) High Durability

As figure 1.1.2 shown in below, the ball screw of YOSO MOTION is designed with Gothic arch groove, which makes the screw easy to rotate even using minimum axial play. To make the rigidity more appropriate to using condition, you can change the preload between one two screw nuts to reduce axial play.

Table 1.1.1 Material and Heat Treatment

Item	Material	Hardness
Screw	SCM450 SSSc	HRC 58°~62°
Nut	SCM415H	HRC 58°~62°
Steel Ball	SUJ2	HRC 62°UP

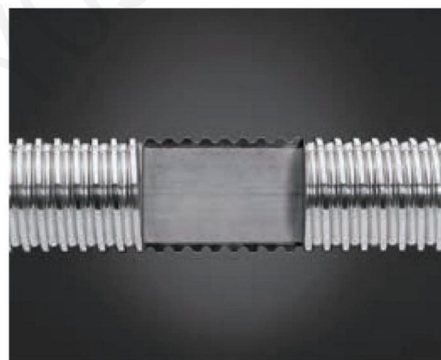
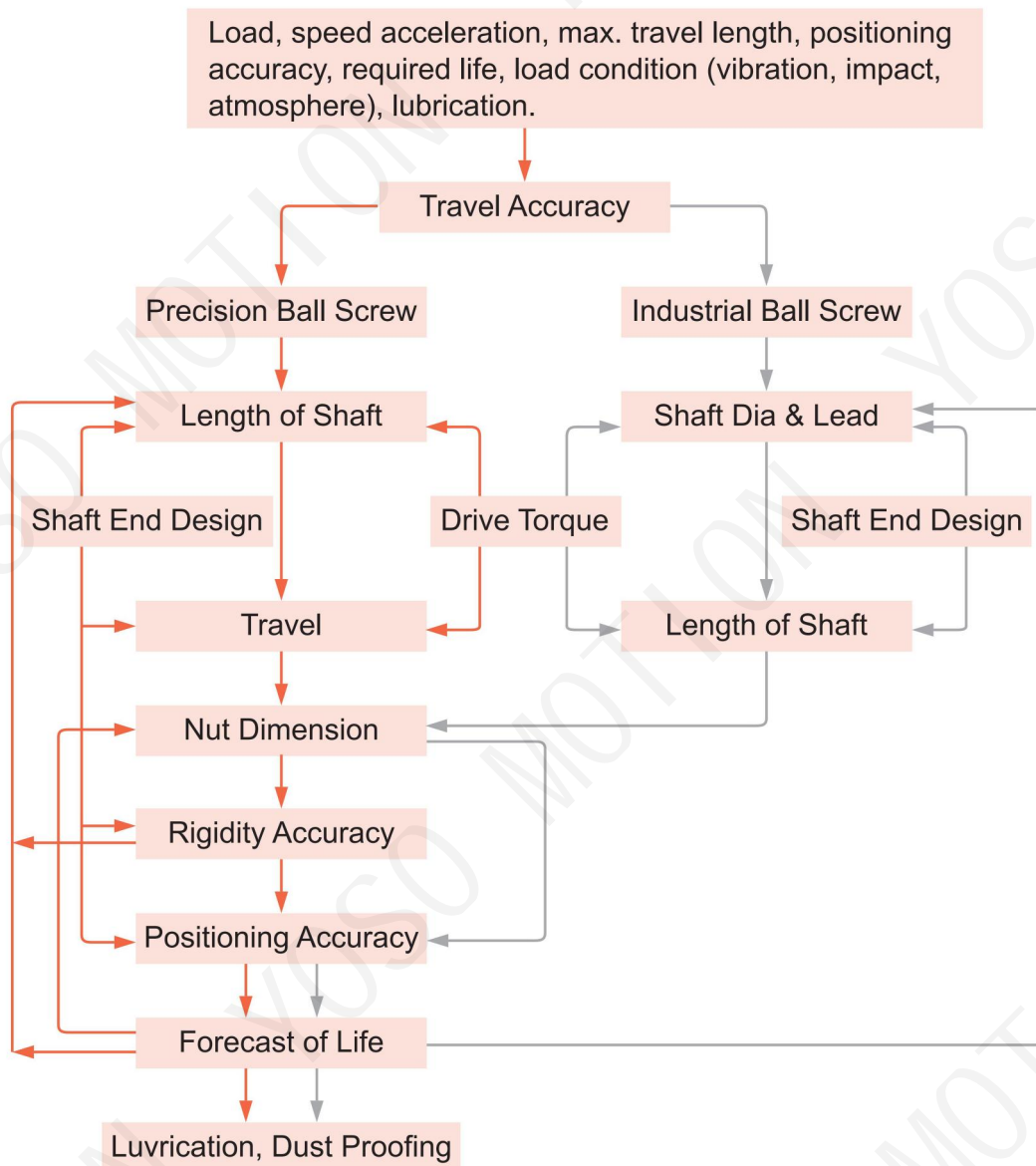

Fig 1.1.5 Heat Treatment

1-1 Ball Screw Selection Procedure



Accuracy (C05)
 Screw Shaft Design (C11)
 Drive Torque (C17)
 Nut Design (C19)

Rigidity (C21)
 Positioning Accuracy (C24)
 Life Design (C26)
 Lubrication and safety design (C32)

1-3 Accuracy

1-3-1 Lead/Travel Accuracy

According to the standard of JIS, we classified our lead accuracy through E, e, e_{300} and $e_{2\pi}$, four main regulations. As figure 1.3.11.3 shown in below, all the definition and tolerance are specified to test the accumulated travel deviations for grade C7 and C10, the tolerance will be chosen in random 300mm of useful length and evaluated if it is qualified with the e_{300} table of 1.3.3.

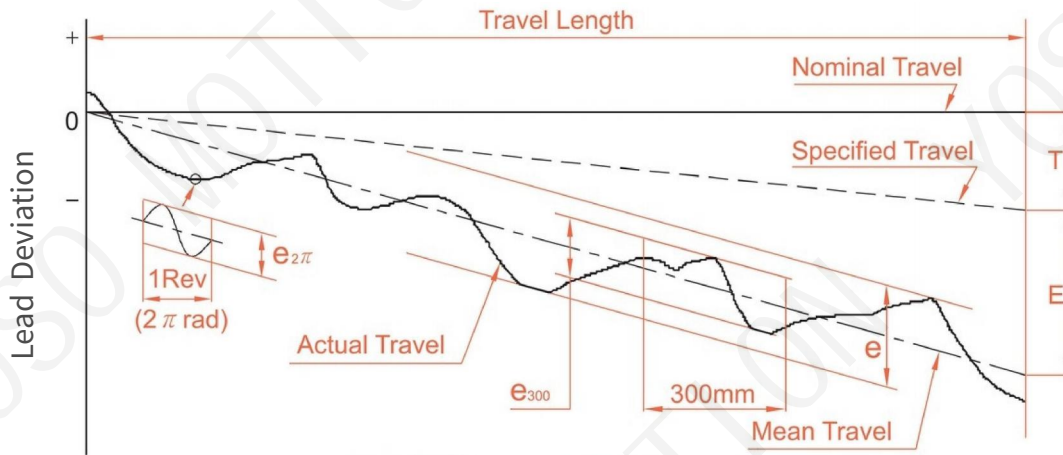

Fig 1.3.1 Diagram of Lead Accuracy

Terms	Reference	Definition	Allowable
Travel Compensation	T	Travel compensation is the deduction between specified and nominal travel in the useful travel. A slightly smaller value compared with nominal travel is often selected by customer, to compensate for an expected elongation caused by temperature rise or external load. Therefore "T" is usually a negative value. <i>Note: if no compensation is needed, specified travel is the same as nominal travel.</i>	
Actual Travel		Actual travel is the axial displacement of the nut relative to the screw shaft.	
Mean Travel		Mean travel is the linear best fit line of actual. This could be obtained by the least squares method. This line represents the tendency of actual travel.	
Mean Travel Deviation	E	Mean travel deviation is the deduction between mean travel and specified	Table 1.3.2
Travel Variations	e	Travel variations is the coverage of 2 lines drawn parallel to the mean travel	Table 1.3.2
	e_{300}	Maximum width of variation within the travel length	Table 1.3.3
	$e_{2\pi}$	Actual width of variation for the length of 300mm taken anywhere within the travel length. Wobble error, actual width of variation for one revolution (2π radian)	Table 1.3.3

1-3 Accuracy

Table 1.3.2 Mean Travel Deviation ($\pm E$) and Travel Variation (e) (JIS B1192)

Unit: μm

Travel Length (mm)	Grade		C1		C2		C3		C4		C5		C7	C10
	Over	Incl.	Over	e	Over	e	Over	e	Over	e	Over	e	e	e
		100	3	3	3.5	5	5	7	8	8	18	18	$\pm 50/300\text{mm}$	$\pm 210/300\text{mm}$
	100	200	3.5	3	4.5	5	7	7	10	8	20	18		
	200	315	4	3.5	6	5	8	7	12	8	23	18		
	315	400	5	3.5	7	5	9	7	13	10	25	20		
	400	500	6	4	8	5	10	7	15	10	27	20		
	500	630	6	4	9	6	11	8	16	12	30	23		
	600	800	7	5	10	7	13	9	18	13	35	25		
	800	1000	8	6	11	8	15	10	21	15	40	27		
	1000	1250	9	6	13	9	18	11	24	16	46	30		
	1250	1600	11	7	15	10	21	13	29	18	54	35		
	1600	2000			18	11	25	15	35	21	65	40		
	2000	2500			22	13	30	18	41	24	77	46		
	2500	3150			26	15	36	21	50	29	93	54		
	3150	4000			30	18	44	25	60	35	115	65		
	4000	5000					52	30	72	41	140	77		
	5000	6300					65	36	90	50	170	93		
	6300	8000							100	60	210	115		
	8000	10000									260	140		
	10000	12500									320	170		

Table 1.3.3 Variation per 300mm (e_{300}) and Wobble Error ($e_{2\pi}$) (JIS B1192)

Unit: μm

Grade	C0	C1	C2	C3	C5	C7	C10
e_{300}	3.5	5	7	8	18	50	210
$e_{2\pi}$	2.5	4	5	6	8		

■ 1-3-2 Axial Play

Axial play of YOSO MOTION's precision ball screw is shown in

Table 1.3.3 Variation per 300mm (e_{300}) and Wobble Error ($e_{2\pi}$) (JIS B1192)

Unit: μm

Grade	P0	P1	P2	P3	P4
e_{300}	Yes	No	No	No	No
$e_{2\pi}$	No	No	Light	Medium	Heavy

Excessive preload increases the friction torque and generates heat which will reduce the life expectancy. However, insufficient preload will reduce stiffness and increase the possibility of lost motion. YOSO MOTION recommends that the preload applied on CNC machine tools should not be heavier than 8% of the dynamic load; 5% for industrial automation X-Y table,

Table 1.3.5 The reference spring force of (P2)

Model No.	Spring Force(Kg) Single Nut	Spring Force(Kg) Double Nut
1605	0.1~0.3	0.3~0.6
2005	0.1~0.3	0.3~0.6
2505	0.2~0.5	0.3~0.6
3205	0.2~0.5	0.5~0.8
4005	0.2~0.5	0.5~0.8
2510	0.2~0.5	0.5~0.8
3210	0.3~0.6	0.5~0.8
4010	0.3~0.6	0.5~0.8
5010	0.3~0.6	0.8~1.2
6310	0.6~1.0	0.8~1.2
8010	0.6~1.0	0.8~1.2

Table 1.3.6 Axial Play(P0) Clearance in the Axial Direction of Rolled and Ground Ball Screw Unit: μm

Nominal Diameter	Rolled Ball Screw Clearance in the Axial Direction (max.)	Ground Ball Screw Clearance in the Axial Direction (max.)
004~014 miniature ball screw	0.05	0.015
015~040 middle size of ball screw	0.08	0.025
050~0100 big size of ball screw	0.12	0.05

1-3 Accuracy

■ 1-3-3 Definition of Mounting Accuracy and Tolerance on Ball Screw

The main items of the mounting accuracy of ball screw are listed in below.

- (1) Periphery run-out of the supporting part of the screw shaft to the screw groove.
- (2) Concentricity of a mounting portion of the shaft to the adjacent ground portion of the screwshaft.
- (3) Perpendicularity of the shoulders to the adjacent ground portion of the screw shaft
- (4) Perpendicularity of the nut flange to the axis of the screw shaft.
- (5) Concentricity of the ball nut diameter to the screw groove.
- (6) Parallelism of the mounting surface of a ball nut to the screw groove.
- (7) Total run-out of the screw shaft to the axis of the screw shaft.

All **YOSO MOTION** ball screws are manufactured, inspected and guaranteed to be within specifications.

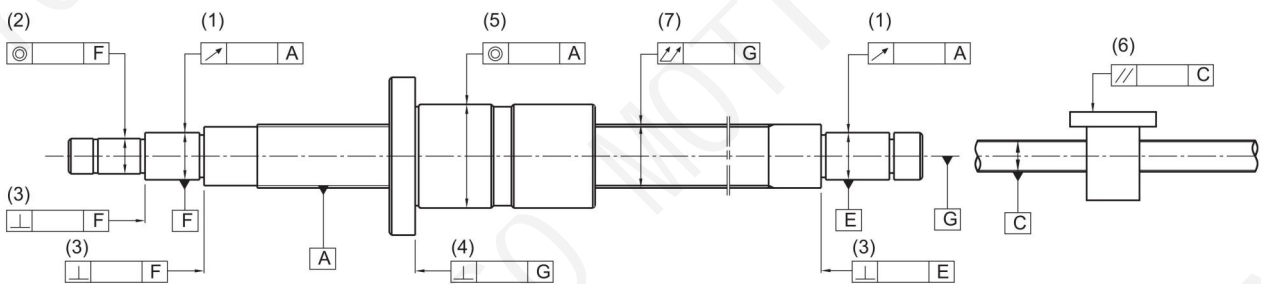

Fig 1.3.2 Mounting Accuracy and Tolerance

1-3-4 Preload Torque

As figure 1.3.3 shown in below, it specified all the type of preload torque generated by rotating a preloaded ball screw.

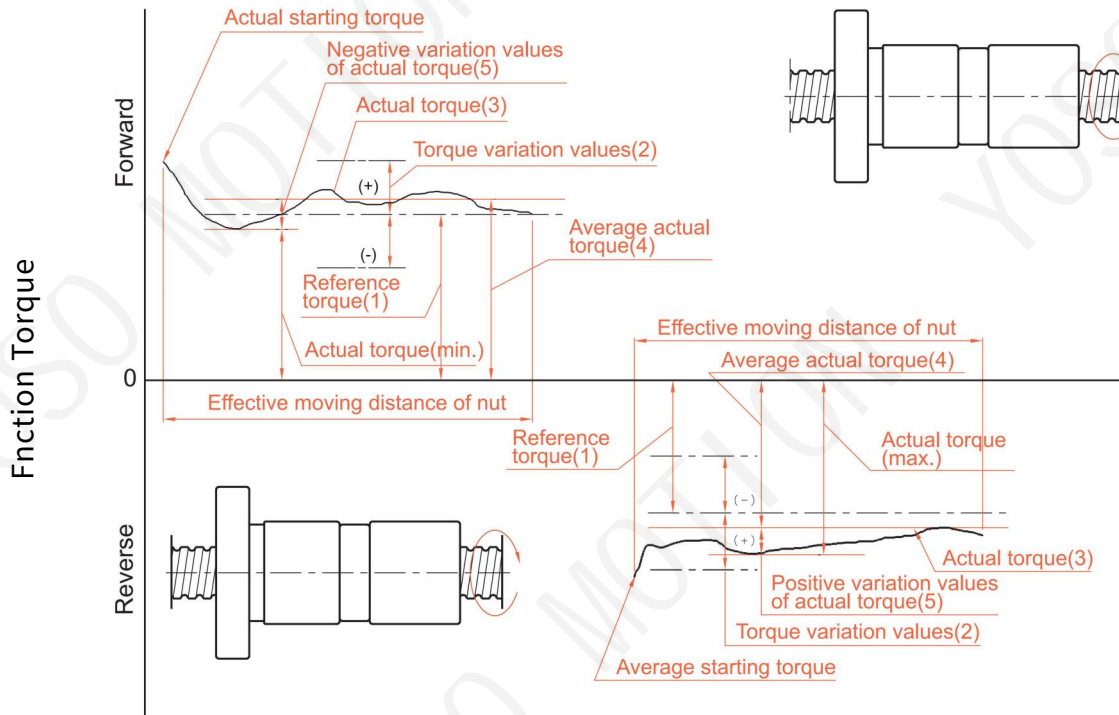

Fig 1.3.3 Descriptions of preload torque

Glossary

(1)Preload

To generate the inner force inside the ball screw to decrease the clearance and increase the rigidity, a set of one gage(approximately 2 μ) larger steel balls is filled inside the nut or two nuts which are executing mutual displacement in axial direction.

(2)Preload dynamic torque

The dynamic torque required for continuously rotating the screws shaft or the nuts under unload condition and the preload has applied to the ball screws.

(3)Reference torque

The targeted preload dynamic torque Fig 1.3.3-(1)

(4) Torque variation values

The variation values of the targeted preload torque variation rates are specified generally based on JIS standards as indicated in Fig 1.3.3.

(5)Torque variation rate

The variation ratio of reference torque

(6) Actual torque

The actual measured preload dynamic torque of the ball screws.

(7)Average actual torque

The arithmetic average of the maximal and minimal actual torque values measured when the nuts are doing reciprocating movements.

(8) Actual torque variation values

After the nut doing reciprocating movements on the effective length of the thread, the biggest variation tested will be the actual torque variation value, which is covered between the positive and negative minimum value relative to the actual torque.

(9)Actual torque variation rate

The rate of actual torque variation values in relation of the average actual torque.

1-3 Accuracy

Table 1.3.7 Permissible ranges of torque variation rates

Reference torque kgf·cm		Effective threading length mm										
		Below 4000								4000~10000		
		Slenderness 1 : below 40				Slenderness 1 : 40~1 : 60				-		
		Grade				Grade				Grade		
Over	Inc1	C0	C1	C2,C3	C5	C0	C1	C2,C3	C5	C1	C2,C3	C5
2	4	±35%	±40%	±45%	±55%	±45%	±45%	±55%	±65%	-	-	-
4	6	±25%	±30%	±35%	±45%	±38%	±38%	±45%	±50%	-	-	-
6	40	±20%	±25%	±30%	±35%	±30%	±30%	±35%	±40%	-	±40%	±45%
10	25	±15%	±20%	±25%	±30%	±25%	±25%	±30%	±35%	-	±35%	±40%
25	63	±10%	±15%	±20%	±25%	±20%	±20%	±25%	±30%	-	±30%	±35%
63	100	-	-	±15%	±20%	-	-	±20%	±25%	-	±25%	±30%

Remarks :1.Slenderness is the value of dividing the screws shaft outside diameter with the screws shaft threading length.
2.For reference torque less than 2 kgf cm,YOSO MOTION specifications will apply.

Calculation of Reference Torque T_p

The equation for computing reference torque of the ball screws is given in following:

$$T_p = 0.05 (\tan\beta)^{-0.5} \cdot \frac{F_{ao} \cdot \ell}{2\pi}$$

Where, F_{ao} = Preload (kgf)

β = Lead angle

ℓ = Lead (cm)

Measurement Conditions

The measure condition as indicated in Fig 1.3.4,the preload dynamic torque will be the multiplication of F (The force to make the nut stay still during rotating the screw)and L (The arm of force).

$$T_p = F \cdot L$$

Measure conditions

- (1)Measurement is executed under the condition of unattached with scraper.
- (2)The rotating speed during measurement maintains at 100 rpm.
- (3)According to JSK2001(industrial lubrication oil-viscosity standard),the ubrication oil use should be in compliance with Is0 VG68

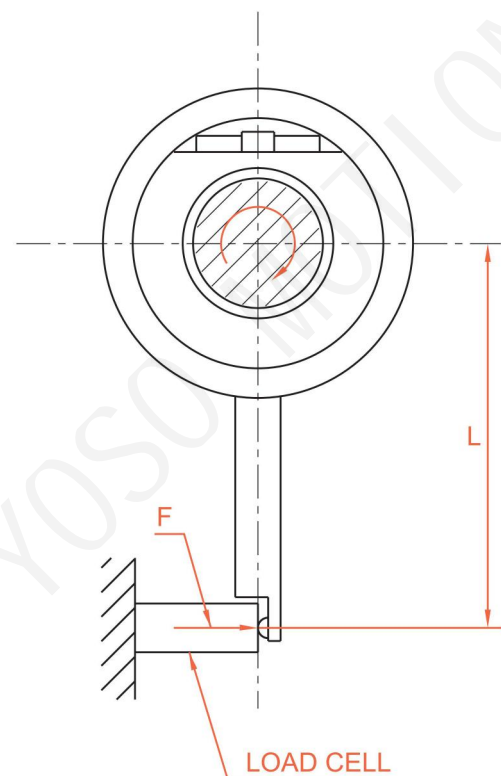

Fig 1.3.4 Preload dynamic torque measuring method

1-3 Screw Shaft Design

1-4-1 Mounting Methods

It's important to consider mounting method (Fig 1.4.1~1.4.8) during your selection of ball screwspecification. If you have special requirement related with mounting method, please consult YOSO MOTION.

(Mounting Screw and Nut)

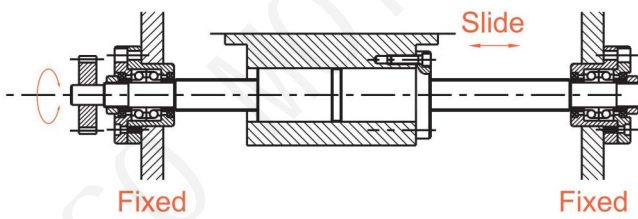

Fig 1.4.1

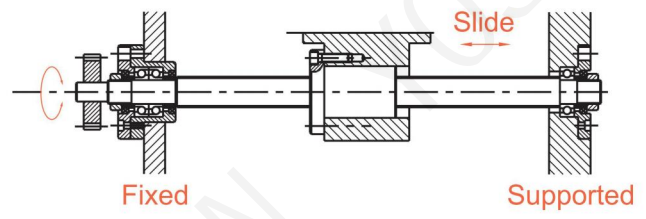

Fig 1.4.5

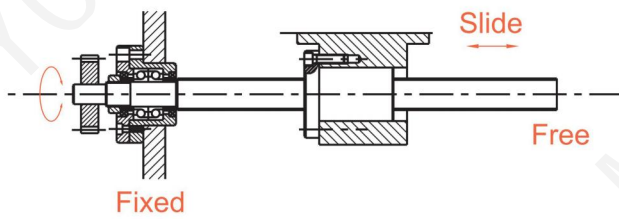

Fig 1.4.2

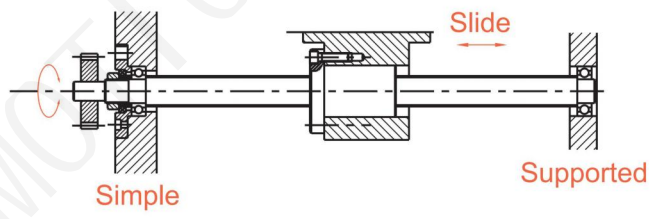

Fig 1.4.6

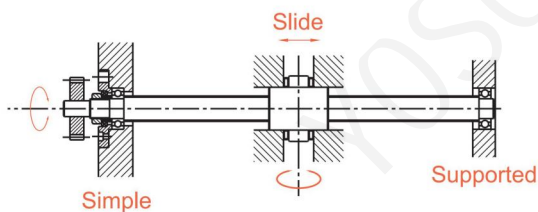

Fig 1.4.3

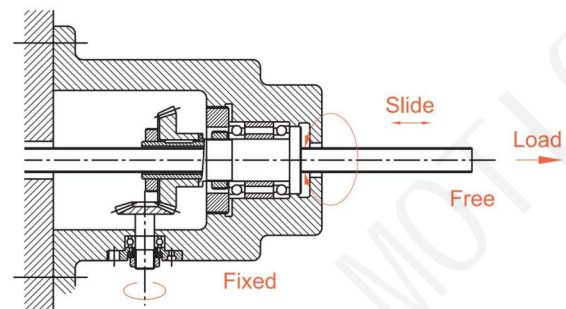

Fig 1.4.7

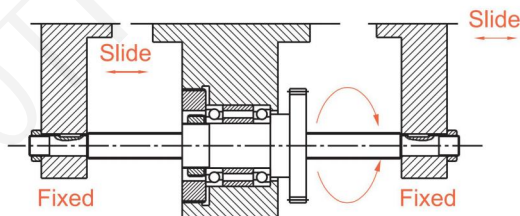

Fig 1.4.4

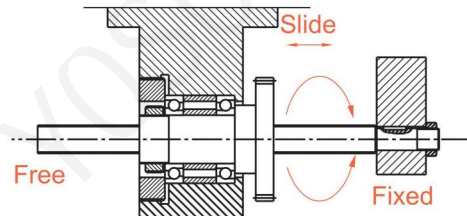

Fig 1.4.8

1-4 Screw Shaft Design

(The mounting method for common types of machinery.)

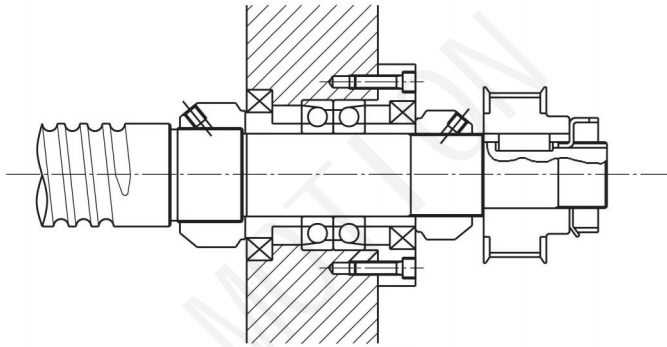

Fig 1.4.9

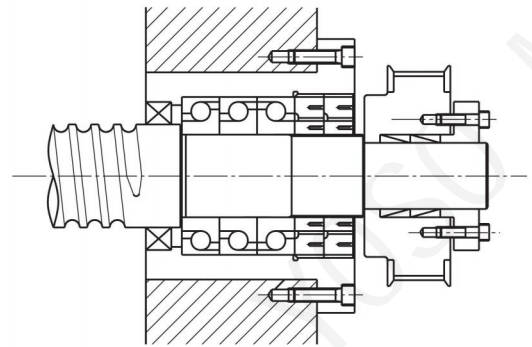

Fig 1.4.11

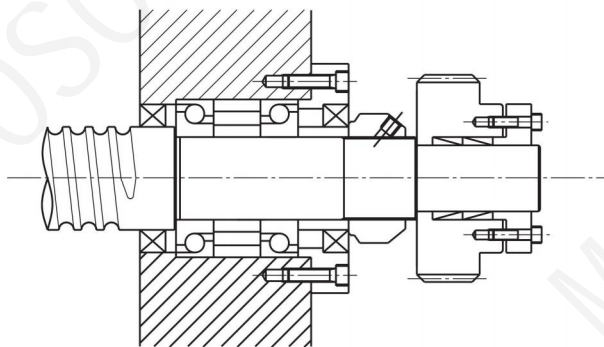

Fig 1.4.10

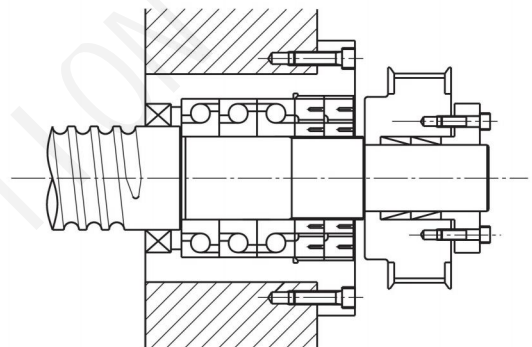

Fig 1.4.12

(The mounting method for bearing in a given pretension.)

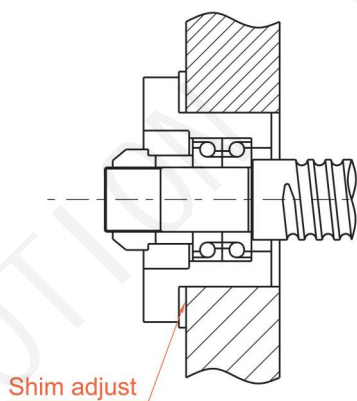

Fig 1.4.13

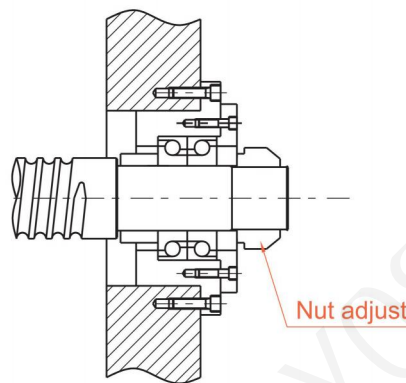

Fig 1.4.14

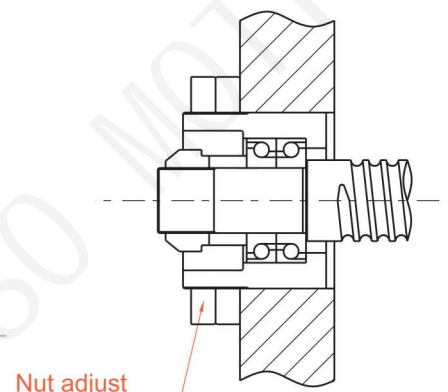

Fig 1.4.15

■ 1-4-2 Allowable Load of Axial Direction

(1) Buckling Load

The safety of the screw shaft against buckling needs to be checked when the shaft is expected to receive buckling loads. Fig 1.4.16 shows a diagram which summarizes the allowable compressive load for buckling for each nominal outside diameter of screw shaft. (Calculate with the equations shown in below when the nominal, outside diameter of the screw shaft exceeds 125mm)

Select the graduation of allowable axial load according to the method of ball screw support-method.

$$P = \alpha \cdot \frac{I \cdot N \cdot \pi^2 \cdot E}{L^2} = m \frac{dr^4}{L^2} \cdot 10^3$$

Where

α = Safety Factor ($\alpha = 0.5$)

E : Vertical elastic modulus ($E = 2.1 \cdot 10^4 \text{ kgf/mm}^2$)

I : Min. secondary moment of screw shaft sectional area

$$I = \frac{\pi}{64} dr^4 (\text{mm}^4)$$

dr : Screw shaft root diameter (mm)

L : Mounting distance (mm)

m · N : Coefficient determined from mounting method of ball screw

Floated-Floated m = 5.1 (N = 1)

Fixed-Floated m = 10.2 (N = 2)

Fixed-Fixed m = 20.3 (N = 4)

Fixed-Free m = 1.3 (N = 1/4)

(2) Allowable Tensile/Buckling Load

With shorter mounting distance, please calculate the two items describe in below

1. The allowable tensile/ buckling load which equals to the derating stress.

2. Allowable load of the screw's groove.

$$P = \sigma A = 11.8 dr^2 (\text{kgf})$$

Where.

P: Buckling load (kgf)

σ : Allowable tensile compressive stress (kgf/mm²)

A: Sectional area of screw shaft root bottom diameter (mm²)

dr : Screw shaft root diameter (mm)

1-4 Screw Shaft Design

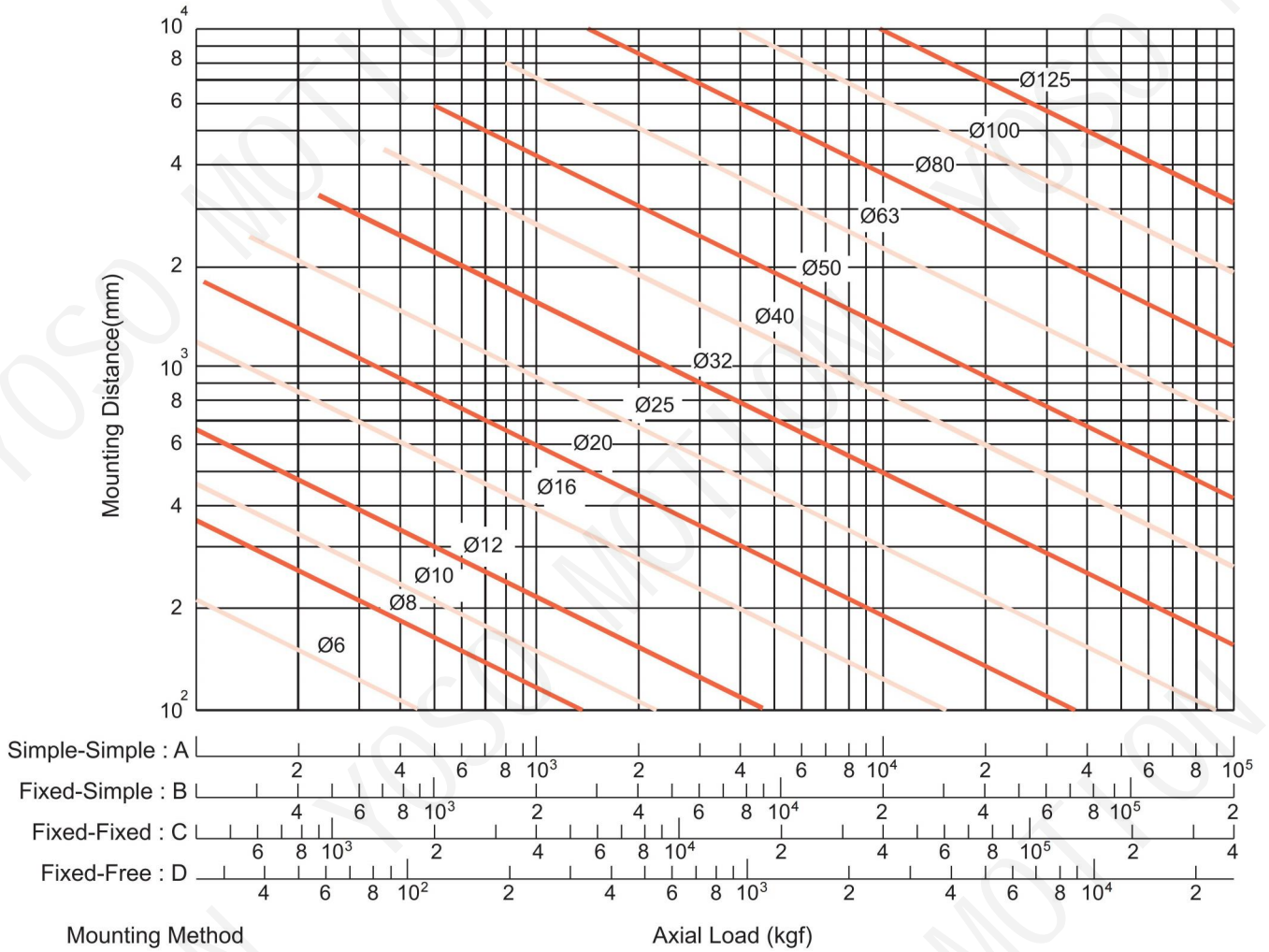

Fig 1.4.16 Buckling Load vs. Nominal Diameter and length

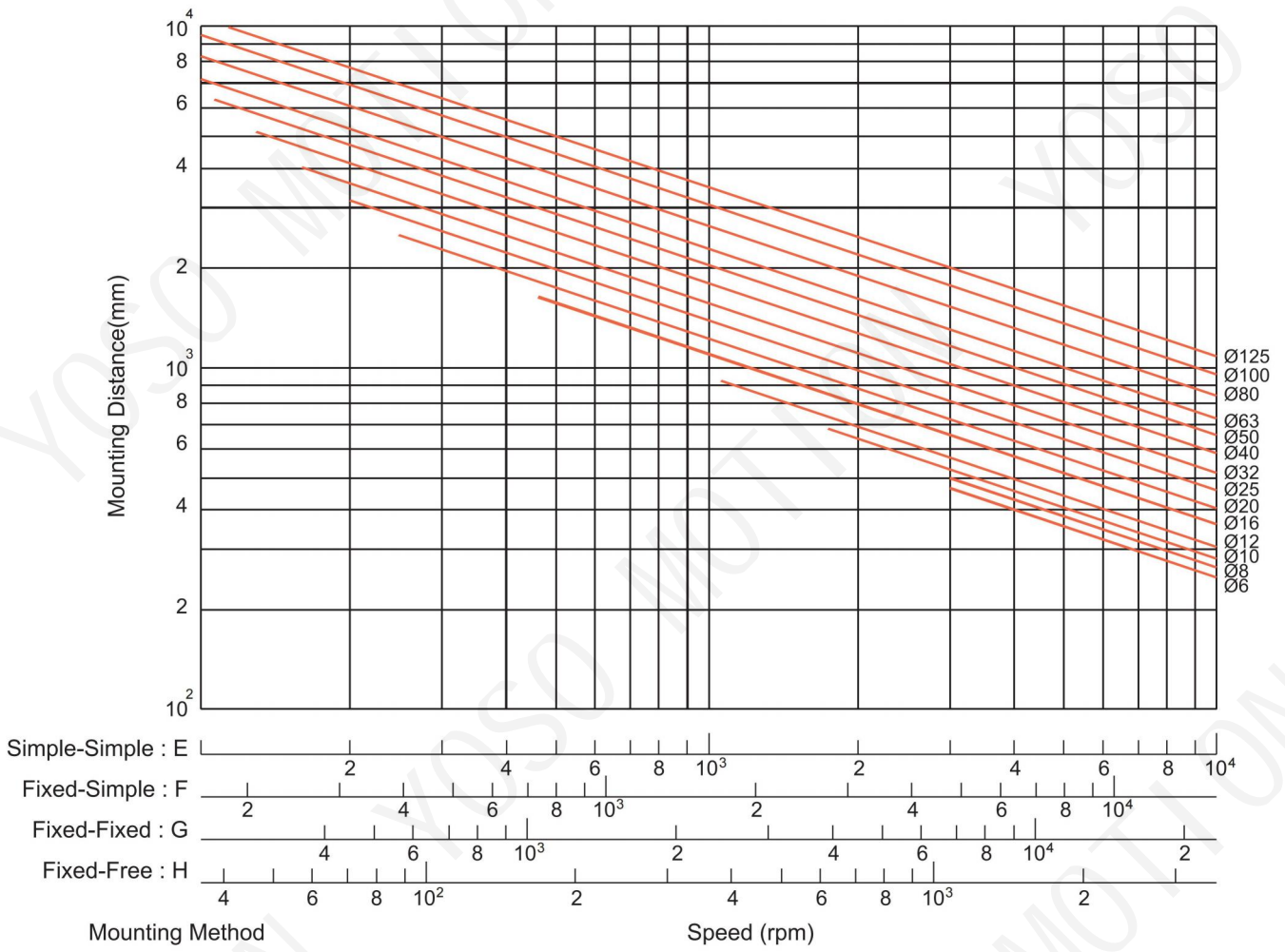

Fig 1.4.17 Buckling Load vs. Nominal Diameter and length

1-4 Screw Shaft Design

■ 1-4-3 Critical Speed

(1) Dangerous speed

To prevent the screw's natural frequency attain resonance which will occur critical speed, it's necessary to look into the ball screw allowable rotation speed (Below 80% of the Critical Speed). More detail of allowable rotation speed classified though screw diameter please refer to Fig 1.4.17.

(2) $d_m \cdot n$ value

The allowable rotation speed is regulated also by the $D_m \times N$ value (D_m : diameter of central circle of steel ball, N : Revolution speed, rpm) which expresses the peripheral speed.

Generally,

For precision

(accuracy grade C7 to C0)
 $D_m \times N \leq 70,000$

For general industry (C10)
 $D_m \times N \leq 50,000$

If your requirement about the product will exceed the limitation, please contact with YOSOMOTION to discuss the detailed solution for the idea product.

*When e , the ratio of screw length and shaft diameter has exceeded 70, please contact with YOSOMOTION to arrange the special arrangement for production.

$$n = \alpha \cdot \frac{60\lambda^2}{2\pi L^2} \sqrt{\frac{E I g}{\gamma A}} = f \frac{d_r}{L^2} \cdot 10^7 (\text{rpm})$$

Where

α : Safety factor ($\alpha = 0.8$)

E : Vertical elastic modulus ($E = 2.1 \cdot 10^4 \text{ kgf/mm}^2$)

I : Minimum secondary torque of axial section plane

$$I = \frac{\pi}{64} d_r^4 (\text{mm}^4)$$

d_r : Screw shaft root diameter (mm)

g : Acceleration of gravity ($g = 9.8 \cdot 10^3 \text{ mm/s}^2$)

γ : Density ($\gamma = 7.8 \cdot 10^{-6} \text{ kgf/mm}^3$)

A : Screw shaft sectional area ($A = \pi d_r^2 / 4 \text{ mm}^2$)

L : Mounting distance (mm)

f, λ : Coefficient determined from the ball screw mounting method

Floated-Floated $f = 9.7$ ($\lambda = \pi$)

Fixed-Floated $f = 15.1$ ($\lambda = 3.927$)

Fixed-Fixed $f = 21.9$ ($\lambda = 4.730$)

Fixed-Free $f = 3.4$ ($\lambda = 1.875$)

1-5 Driving Torque

1-5-1 Driving torque T_s of the transmission shaft

$T_s = T_P + T_D + T_F$ (in fixed speed)

$T_s = T_G + T_P + T_D + T_F$ (when accelerating)

T_G : Acceleration torque (1) T_P : Load torque (2)

T_D : Preload torque (3) T_F : Friction torque (4)

(1) Acceleration T_G

$$T_G = J\alpha (\text{kgf} \cdot \text{cm})$$

$$\alpha = \frac{2\pi n}{60\Delta t} (\text{rad/s}^2)$$

J : Moment of inertia ($\text{kgf} \cdot \text{cm} \cdot \text{s}^2$)

α : Angular acceleration (rad/s^2)

n : Revolutions (min^{-1})

Δt : Starting time (sec)

(3) Preload torque T_D

$$T_D = \frac{K \cdot P_{PL} \cdot \ell}{\sqrt{\tan \alpha} \cdot 2\pi} (\text{kgf} \cdot \text{cm})$$

K : Internal coefficient

(0.05 is usually adopted)

P_{PL} : Preload (kgf)

ℓ : Lead (cm)

α : Lead angle

(4) Friction torque T_F

$$T_F = T_B + T_O + T_J (\text{kgf} \cdot \text{cm})$$

T_B : Friction torque of bracing shaft

T_O : Friction torque of free shaft

T_J : Friction torque motor shaft

(2) Lead torque T_P

$$T_P = \frac{P \cdot \ell}{2\pi\eta_1} (\text{kgf} \cdot \text{cm})$$

$$P = F + \mu Mg$$

P : Axial load (kgf)

ℓ : Lead (cm)

η_1 : Positive efficiency

The efficiency when rotating motion is altered to linear motion

F : Cutting force (kgf)

μ : Friction

M : Mass of moving object (kg)

g : Acceleration of gravity (9.8 m/s^2)

$$T_P = \frac{P \cdot \ell \cdot \eta_2}{2\pi} (\text{kgf} \cdot \text{cm})$$

η_2 : Reverse efficiency

The efficiency when linear motion returns to rotating motion

The friction torque of the bracing shaft would be affected by the volume of lubrication oil. Besides be careful with the excessive tight end seal may lead to unexpected over friction torque or temperature rise.

【For reference】 Moment of inertia of load (refer to Table 1.5.1)

$$J = J_{BS} + J_{Cu} + J_W + J_M$$

J_{BS} : Moment of inertia Ball screws shaft

J_{Cy} : Moment of inertia Coupler

J_W : Moment of inertia Linear motion part

J_m : Moment of inertia Roller shaft part of motor shaft

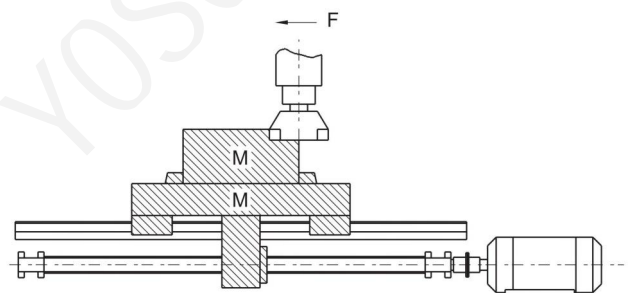

Fig 1.5.1 Moment of inertia of load

1-5 Driving Torque

Table 1.5.1 Conversion formula for moment of inertia of load

Formula	J
Moment of inertia converted from motor shaft	
Cylinder load	$\frac{\pi \rho L D^4}{32}$
Linearly moving object	$\frac{M}{4} \left(\frac{V \ell}{\pi \cdot N_M} \right)^2 = \frac{M}{4} \left(\frac{P}{\pi} \right)^2$
Unit	kg.m ²
Moment of inertia during deceleration	$J_M = \left(\frac{J_\ell}{N_M} \right)^2 J_\ell$

ρ : Density (kg/m³) $\rho = 7.8 \cdot 10^3$

L: Cylinder length (m)

D: Cylinder diameter (m)

M: Mass of the linear motion part (kg)

V: Velocity of the linear moving object (m/min)

N_M : Motor shaft revolutions (min⁻¹)

P: The moving magnitude of the linearly moving object per rotation of the motor (m)

N_ℓ : Rotations in longitudinal moving direction (min⁻¹)

J_ℓ : Moment of inertia in load direction

J_M : Moment of inertia in motor direction

1-6-1 Selection of Nut

(1) Series

When making selection of series, please take demanded accuracy, intended delivery time dimensions (the outside diameter of screw, ratio of lead/the outside diameter of screw) preload and etc into consideration.

(2) Circulation type

Selection of circulation type: Please consider the efficiency of screw nut's mounting space. The advantage of each circulation type will be specified in figure 1.6.1.

(3) Number of loop circuits

Performance and service life should be considered when selecting number of loop circuits.

(4) Shape of flanges (FLANGE)

Please make selection based on the available space for the installation of nuts.

(5) Oil hole

Oil holes are provided for the precision ball screws, please use them during machine assembly and regular furnishing.

1-6 Nut Design

Table 1.6.1 Circulation type

Circulation type	Model		Characteristic
	Single Nut	Double	
Internal circulation type	SFM SFNI SFK SFNU BSH	DFM	<ul style="list-style-type: none"> ● Delicated diameter of screw takes only little space. ● Applicable to those with smaller lead /the outside diameter of the screw
External circulation type	SFV XSV BSH	DFV	<ul style="list-style-type: none"> ● Economy ● Applicable to larger lead and diameter. ● Applicable for high loading purpose. (YOSOMOTION patent nut)
End-caps circulation type	SFY SFH SFA	DFS	<ul style="list-style-type: none"> ● Suitable for high speed positioning)

1-6-2 Nut Types

U,I,M-Type Nut

In these types of nuts, by using the internal circulator which makes the ball pass over the crest diagonally, the ball will return to the starting point. Normally, one roll of balls will fit with one circulation. As figure 1.6.1 specified, these types of nuts need at least one side which is completely tooth passing, which is applicable for smaller shaft diameter.

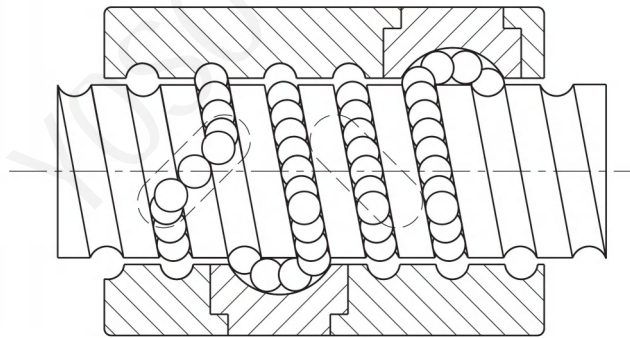

Fig 1.6.1 U,I,M-Type Nut

K-Type Nut

It applies the similar circulation as that of I-type, but circulation takes place in keyslots of identical angle for different circulation. (see Fig 1.6.2)

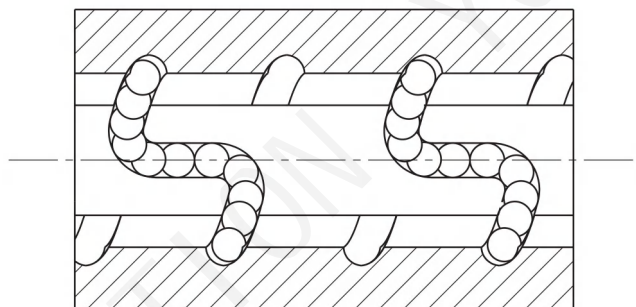

Fig 1.6.2 K-Type Nut

1-6 Nut Design

V-Type Nut

Using outer circulation, the special design of circulator allows the balls to roll along the thread direction. By so, the smoothness of circulation is increased and meanwhile decrease the mutual collision. It's a suitable type for high speed and heavy loading.

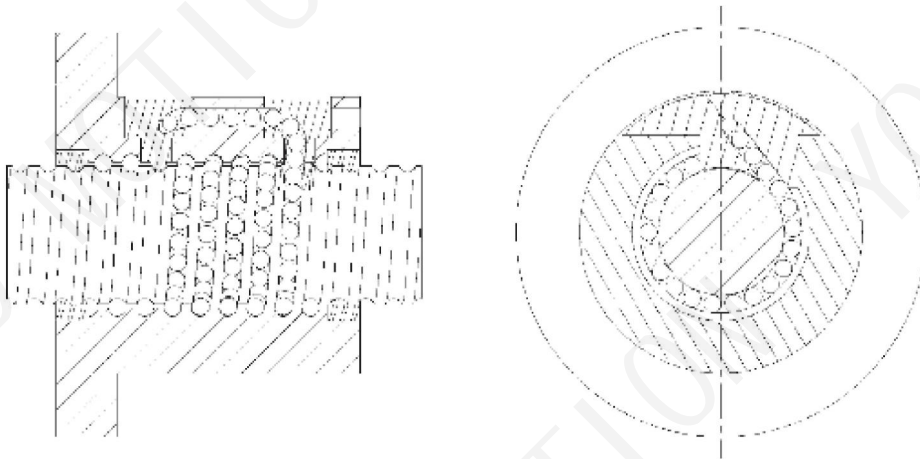

Fig 1.6.3 V-Type Nut

Y,H,A-Type Nut

By using thin and flexible dust cap on both side, the performance of wiping had been enhanced. Moreover, the enhancement of circulation structure increase both the function of high rigidity and speed.

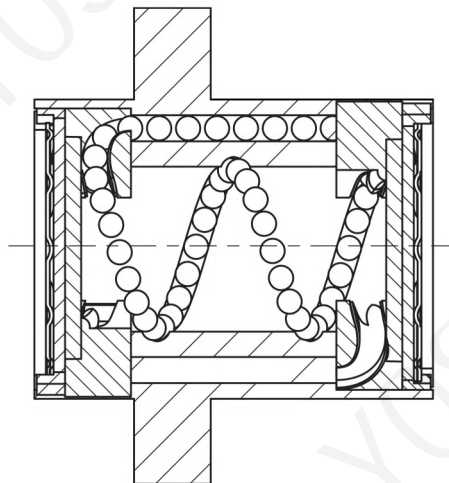

Fig 1.6.4 Y,H,A-type nut

1-7 Rigidity

Excessively weak rigidity of the screw's peripheral structure is one of the primary causes that result in lost motion. Therefore, in order to achieve excellent position accuracy for the precision machines such as NC working machines and etc, axial rigidity balance as well as torsional rigidity for the parts at various portions of the transmission screw have to be taken into consideration at time of designing.

Static Rigidity K

The axial elastic deformation and rigidity of the transmission screw system can be determined by the formula below.

$$K = \frac{P}{e} \text{ (kgf/mm)}$$

P: Axial load (kgf) borne by the transmission screw system

e: Axial flexural displacement (mm)

$$\frac{1}{K} = \frac{1}{K_S} + \frac{1}{K_N} + \frac{1}{K_B} + \frac{1}{K_H} \text{ (mm/kgf)}$$

K_S: Axial rigidity of screw shaft (1)

K_B: Axial rigidity of support shaft (3)

K_N: Axial rigidity of nut (2)

K_H: Axial rigidity of installation (4)

(1) Axial rigidity K_S and displacement δ_S

$$K_S = \frac{P}{\delta_c} \text{ (kgf/mm)}$$

P: Axial load (kgf)

For places of Fixed -Fixed installation

For places other than Fixed -Fixed installation

$$\delta_{SF} = \frac{PL}{4AE} \text{ (mm)}$$

$$\delta_{SS} = \frac{PL_0}{AE} \text{ (mm)}$$

$$\delta_{SS} = 4\delta_{SF}$$

δ_{SF}: Directional displacement at places of fixed-fixed

δ_{SS}: Directional displacement at places excluding fixed-fixed installation

A: Cross-sectional area of the screw shaft tooth root diameter (mm²)

E: Longitudinal elastic modulus (2.1 10⁴kgf/mm²)

L: Distance between installations (mm)

L₀: Distance between load applying points (mm)

1-7 Rigidity

(2) Axial rigidity K_N and displacement δ of nuts

$$K_N = \frac{P}{\delta_s} \text{ (kgf/mm)}$$

(a) In case of single nut

$$\delta_{NS} = \frac{K}{\sin\beta} \left[\frac{Q^2}{d} \right]^{\frac{1}{3}} \cdot \frac{1}{\zeta} \text{ (mm)}$$

$$Q = \frac{P}{n \cdot \sin\beta} \text{ (kgf)}$$

$$n = \frac{D_0 \pi m}{d} \text{ (each)}$$

Q : Load of one steel ball (kgf)

n : Amount of steel ball

k : Constant determined based on material, shape, dimensions

$$k \approx 5.7 \cdot 10^{-4}$$

β : Angle of contact (45°)

P : Axial load (kgf)

d : Steel ball diameter (mm)

ζ : Accuracy, internal structure coefficient

m : Effective amount of balls

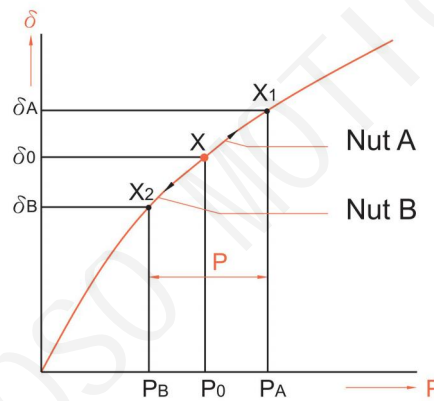

Fig 1.7.1

(b) In case of double nuts

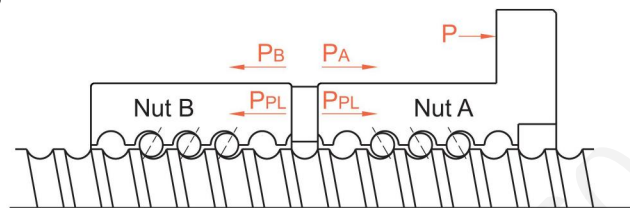

Fig 1.7.2 Preloaded for the double nuts

As bearing weight of preload (PPL) exert, there will be approximately three times of axial loading(P). To eliminate the preload of nut b, please set the bearing weight of preload (PPL) under $1/3$ of the maximum axial load weight. Take $0.25 C_a$ as maximum load weight of preload. Whethe the displacement under the preload which equals to three times of the bearing load of the axial direction, the value will be $1/2$ of single nut's displacement.

$$K_N = \frac{P}{\delta_{NW}} = \frac{3P_{PL}}{\delta_{NS/2}} = \frac{6P_{PL}}{\delta_{NS}} \text{ (kgf/mm)}$$

δ_{NS} : Displacement of single nut(mm)

δ_{NW} : Displacement of double nuts(mm)

(Explanation of the rigidity of double nuts)

As shown in Fig 1.7.1 and 1.7.2, when a preload PPL is applied on the nut A and B both nuts A, B would produce flexural deformations that will reach point X. If an external force P is exerted from here, nut A moves from point X to point X1, while nut B moves from X to X2.

Then, based on the computing formula for displacement δ_{NS} of the single nut, we can obtain :

$$\delta_0 = aP_{PL}^{\frac{2}{3}}$$

Since nut A and B have the displacement of $\delta_a = aP_{PL}^{\frac{2}{3}}$ while external force (P) gave the same displacement on nut A and B, we can obtain that $\delta_A - \delta_0 = \delta_0 - \delta_B$.

In other cases, if external force applied on nut A and B is P only, and cause the increase of PA, we will get the formula of $P_A - P_B = P$ $\delta_B = 0$

$$P_A - P_B = P$$

$$\delta_B = 0$$

For preventing the external force applied on nut B being absorbed by nut A thus decreasing, so when $\delta_B = 0$

$$aP_A^{\frac{2}{3}} - aP_{PL}^{\frac{2}{3}} = aP_{PL}^{\frac{2}{3}}$$

$$P_A^{\frac{2}{3}} = 2P_{PL}^{\frac{2}{3}}$$

$$P_A = \sqrt[3]{8} P_{PL} = 2P_{PL}$$

As Fig 1.7.3 shown in below, if the axial direction loading weight equals to three times of preload, the single nut's displacement will be cut into half and gain two times stronger of rigidity.

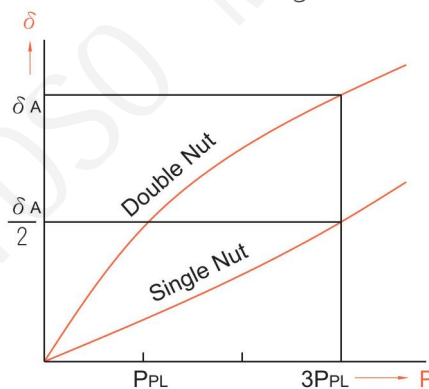

Fig 1.7.3

(3) Axial rigidity K_B and displacement δ_B of support shaft

$$K_B = \frac{P}{\delta_B} \text{ (kgf/mm)}$$

Being the support bearing of ball screw and meanwhile applying on precision machines, we can calculate the rigidity of bevel ball bearing through the formula below.

$$\delta_B = \frac{2}{\sin\beta} \left[\frac{Q^2}{d} \right]^{\frac{1}{3}} \text{ (mm)} \quad Q = \frac{P}{n \cdot \sin\beta} \text{ (kgf)}$$

Q : Load of one steel ball (kgf)

n : Amount of steel balls

β : Angle of contact (45°)

P : Axial load (kgf)

d : Steel ball diameter (mm)

a : Effective stroke

(4) Look into the nut and bearing mounting part's axial direction, the rigidity K_H and displacement δ_H should aware of the requirement of high rigidity on mounting portion during the initial machine development.

$$K_H = \frac{P}{\delta_H} \text{ (kgf/mm)}$$

1-8 Positioning Accuracy

Among the factors that cause feed accuracy errors, lead accuracy and feed system rigidity are the key points for review, while other factors such as heat deformation due to temperature rise as well as assembly accuracy for the guiding surface, etc. should also be considered.

1-8-1 Accuracy Selection

Table 1.8.1 shows the recommended application ranges for various ball screws accuracy classes based on different.

Table 1.8.1 Examples of ball screws accuracy classes for different uses

Application			Accuracy Grade						
			C0	C1	C2	C3	C5	C7	C10
NC Machine Tools	Lathe	X	○	○	○	○	○	○	
		Y				○	○	○	
	Milling Machine Boring Machine	XY		○	○	○	○	○	
		Z			○	○	○	○	
	Machine Center	XY		○	○	○	○		
		Z			○	○	○		
	Jig Borer	XY	○	○					
		Z	○	○					
	Drilling Machine	X				○	○	○	
		Z					○	○	
	Grinding Machine	X	○	○	○	○	○	○	
		Z		○	○	○	○	○	
	Electro-discharge Machine (EDM)	XY		○	○	○	○	○	
		(Z)			○	○	○	○	
	Wire Cut (EDM)	Y		○	○	○			
UV			○	○	○	○	○		
Punching Press	XY				○	○	○		
Laser Cutting Machine	XY				○	○			
	Z				○	○			
Wood Working Machine						○	○	○	○
Machines of General use and special Use					○	○	○	○	○
Semiconductor Machines	Explosure Equipments		○	○					
	Chemical Treatment					○	○	○	○
	Wire Bonder			○	○	○			
	Prober		○	○	○	○			
	Inserter				○	○	○	○	
	PCB Driller				○	○	○	○	
Industrial Robots	Orthogonal Type	As' sy			○	○	○	○	
		Others					○	○	○
	Muliti-joints Type	As' sy			○	○	○		
		Others				○	○	○	
SCARA Type					○	○	○	○	
Machines for Steel molding Injection Molding Machines							○	○	○
Three-Dimensional Measuring Machines			○	○	○				
Business Machines							○	○	
Pattern Image Machines			○	○					
Nuclear	Rod Control					○	○	○	
	Mechnaical Snubber							○	○
	Aircrafts					○	○		

■ 1-8-1 Accuracy Selection

Thermal displacement of the screw shaft results in deterioration of the position accuracy. The magnitude of the thermal displacement is calculated as follows :

$$\Delta l = \alpha \cdot \Delta t \cdot L$$

Δl : Thermal displacement

α : Coefficient of thermal expansion

Δt : Temperature rise (deg) at screw shaft

L: Effective length of screw thread

Namely, the screw shaft develops elongation of 12 μ m per 1m when the temperature rises by 1°C. The ball screw, which lead has been machined to high accuracy, may fail to meet high level requirements because of the thermal displacement due to temperature rise. As high speed is applied during ball screw usage, the heat will rise as well and cause more influence.

The thermal displacement countermeasures for ball screws include the following :

(1) Control of heat generation

- Optimization of preload
- Correct selection and supply of lubricant
- Increase in ball screw lead, with reduced rotation speed

(2) Forced cooling

- Hollow screw shaft to allow cooling fluid to flow through
- Cooling of screw shaft exterior with cooling oil or air

(3) Avoid influence of temperature rise

Warming up the machine through high speed to attain the stable temperature :

- Operates after the temperature become stable
- Pre-tension on screw shaft
- Preset a negative value on target value of the cumulative lead.
- Use the closed loop for positioning

1-9 Service Life Design

1-9-1 Service Life of Ball Screws

Even the ball screw is used under correct conditions, it would still fail after a period time of usage. From the beginning to the unusable condition of ball screw, this period of time is called service life of ball screw, which is generally classified into the fatigue life when delamination phenomenon occurs and the accuracy deterioration life caused by wear-out, etc.

1-9-2 Basic Static Load Rating C_{0a}

The basic load rating is an axial static load which will produce a permanent deformation at contact points of the steel balls to ball grooves equal to 0.01% of ball diameter.

1-9-3 Basic Dynamic Load Rating C_a

The basic dynamic load rating is an axial load which allow 90% of a group of identical ball screws (rotated under the same condition) to rotate without flaking for 10^6 revolutions. This basic dynamic load rating is shown in the table of dimensions.

Relation between load and service life $L \propto \left[\frac{1}{P}\right]^3$ h L : Service life P : Load

1-9-4 Fatigue Life

Average load P_e

(1) When axial load keeps changing, please calculate in order the average load for the equivalent fatigue life under different load condition changes. (see Table 1.9.1)

$$\left(P_e = \frac{P_1^3 n_1 t_1 + P_2^3 n_2 t_2 + \dots + P_n^3 n_n t_n}{n_1 t_1 + n_2 t_2 + \dots + n_n t_n}\right)^{\frac{1}{3}} \text{ (kgf)}$$

Axial Load (kgf)	Rotating Speed (min^{-1})	Time(%)
P_1	n_1	t_1
P_2	n_2	t_2
⋮	⋮	⋮
P_n	n_n	t_n

But, $t_1 + t_2 + t_3 + \dots + t_n = 100$

Table 1.9.1 Service Life in Different Application.

Usage	Life in hours (h)
Working machines	20000
General industrial machines	10000
Automatic control machines	15000
Measurement machines	15000

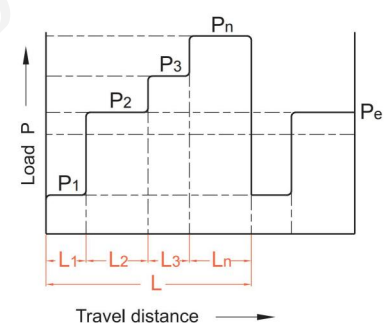

Fig 1.9.1

$$P_e = \frac{2P_{\max} + P_{\min}}{3} \text{ (kgf)}$$

P_{\max} : Maximal axial load (kgf)

P_{\min} : Minimal axial load (kgf)

(2) When load changes according to sine curve (see Fig 1.9.2)

$P_e \cong 0.65 P_{\max}$ (Fig A)

$P_e \cong 0.75 P_{\max}$ (Fig B)

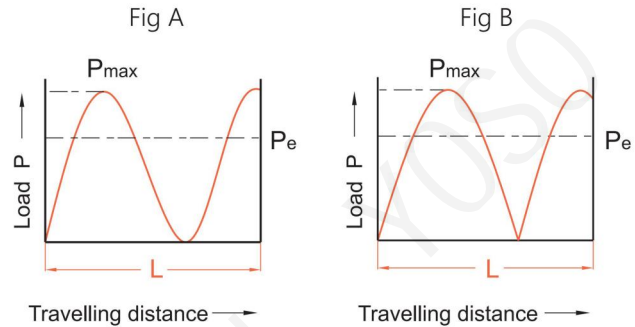

Fig 1.9.2

■ 1-9-5 Calculation of Service Life

The fatigue life is generally expressed by the total number of revolutions. The total rotation hours or total travel distance may also be used to express service life. The fatigue life is calculated as follow :

$$L = \left[\frac{C_a}{P_a \cdot f_w} \right]^3 \cdot 10^6$$

$$L_t = \frac{L}{60n}$$

$$L_s = \frac{L \cdot \ell}{10^6}$$

Where

L : Rated fatigue life (rev)

L_s : Life in travel distance (km)

P_a : Axial load (kgf)

f_w : Load Coefficient

(Required coefficient to operate)

L_t : Life in hours (h)

C_a : Basic dynamic load rating (kgf)

n : Rotating speed (rpm)

ℓ : Lead (mm)

Table 1.9.2 Load Factor (f_w)

Vibration and impact	Velocity (V)	f_w
Minor	$V \leq 0.25$ m/s Very Low	1~1.2
Little	$0.25 < V \leq 1$ m/s Low	1.2~1.5
Moderate	$1 < V \leq 2$ m/s Medium	1.5~2
Heavy	$V > 2$ m/s High	2~3.5

Table 1.9.3 Factor of Safety (f_s)

Usage	Operation	Minor
Machine tool	Normal operation	1.0 ~ 1.3
	Operation with impact and vibration	2.0 ~ 3.0
Industrial machine	Normal operation	1.0 ~ 1.5
	Operation with impact and vibration	2.5 ~ 7.0

Basic Dynamic Load Rating C_a

$$C_a = P_e \cdot f_s$$

Basic Static Load Rating C_{oa}

$$C_{oa} = P_{\max} \cdot f_s$$

1-9 Life Design

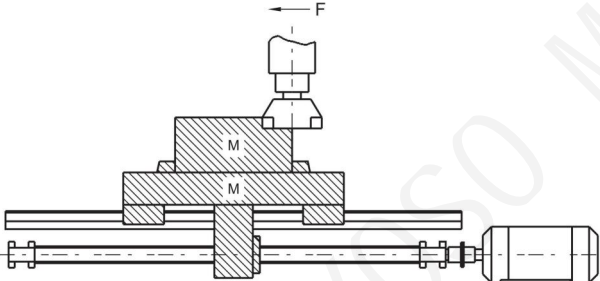
Key Points for Ball Screws Selection	Calculation for Ball Screws Selection																																																		
<p>To choose a perfect fit ball screw, users need to understand operating requirement, which is the fundamental principal of deciding the design. Besides, the main factors of selection include load weight, stroke, torque, positioning accuracy in a single time and repeatedly, rigidity, lead and nut's inner diameter. Among all the factors, any single factor's change will cause the change of other factors. Therefore, the balance between all factors is a must to pay attention to.</p>	<div style="text-align: center;">  </div> <p>Design conditions</p> <ol style="list-style-type: none"> 1. Working table weight 300 Kg 2. Working object weight 400 Kg 3. Max Stroke 700 mm 4. Feeding speed 10 m/min 5. Minimal disassembly ability 10μm/stroke 6. Driving motor DC motor (MAX 1000 min) 7. Guiding surface friction coefficient (μ= 0.05~0.1) 8. Running rate 60 % 9. Accuracy review items 10. Inertia generated during acceleration/deceleration can be neglected because the time periods involved are comparatively small. 																																																		
<p>1. Setting of operation conditions</p> <p>(a) Machine service life time reckoning of H (hr)</p> $H = \text{hours/day} \cdot \text{days/year} \cdot \text{life years} \cdot \text{running rate}$ <p>(b) Mechanical conditions</p> <table border="1" style="width: 100%; border-collapse: collapse;"> <thead> <tr> <th style="background-color: #f4a460;">Calculation Items Different Operations</th> <th style="background-color: #f4a460;">Speed/rotations</th> <th style="background-color: #f4a460;">Cutting resistance</th> <th style="background-color: #f4a460;">Sliding resistance</th> <th style="background-color: #f4a460;">Time used</th> </tr> </thead> <tbody> <tr> <td style="background-color: #f4a460;">Fast feed</td> <td style="background-color: #f4a460;">m/min/min⁻¹</td> <td style="background-color: #f4a460;">kgf</td> <td style="background-color: #f4a460;">kgf</td> <td style="background-color: #f4a460;">%</td> </tr> <tr> <td style="background-color: #f4a460;">Light cutting</td> <td style="background-color: #f4a460;">/</td> <td style="background-color: #f4a460;"></td> <td style="background-color: #f4a460;"></td> <td style="background-color: #f4a460;"></td> </tr> <tr> <td style="background-color: #f4a460;">Medium cutting</td> <td style="background-color: #f4a460;">/</td> <td style="background-color: #f4a460;"></td> <td style="background-color: #f4a460;"></td> <td style="background-color: #f4a460;"></td> </tr> <tr> <td style="background-color: #f4a460;">Heavy cutting</td> <td style="background-color: #f4a460;">/</td> <td style="background-color: #f4a460;"></td> <td style="background-color: #f4a460;"></td> <td style="background-color: #f4a460;"></td> </tr> </tbody> </table> <p>(c) Position determination accuracy</p> <p>Feed accuracy error factor includes load accuracy and system rigidity. Other factors which caused by temperature rise such as heat deformation and mounting accuracy of surface are needed to be considered.</p>	Calculation Items Different Operations	Speed/rotations	Cutting resistance	Sliding resistance	Time used	Fast feed	m/min/min ⁻¹	kgf	kgf	%	Light cutting	/				Medium cutting	/				Heavy cutting	/				<p>1. Setting of operation conditions</p> <p>(a) Machine service life time reckoning of H (hr)</p> $H = 12 \text{ hr} \cdot 250 \text{ days} \cdot 10 \text{ years} \cdot 0.6 \text{ Running rate} = 18000 \text{ hr}$ <p>(b) Mechanical conditions</p> <table border="1" style="width: 100%; border-collapse: collapse;"> <thead> <tr> <th style="background-color: #f4a460;">Calculation Items Different Operations</th> <th style="background-color: #f4a460;">Speed/rotations</th> <th style="background-color: #f4a460;">Cutting resistance</th> <th style="background-color: #f4a460;">Sliding resistance</th> <th style="background-color: #f4a460;">Time used</th> </tr> </thead> <tbody> <tr> <td style="background-color: #f4a460;">Fast feed</td> <td style="background-color: #f4a460;">10m/min/1000min⁻¹</td> <td style="background-color: #f4a460;">0 kgf</td> <td style="background-color: #f4a460;">70 kgf</td> <td style="background-color: #f4a460;">10 %</td> </tr> <tr> <td style="background-color: #f4a460;">Light cutting</td> <td style="background-color: #f4a460;">6/600</td> <td style="background-color: #f4a460;">100</td> <td style="background-color: #f4a460;">70</td> <td style="background-color: #f4a460;">50</td> </tr> <tr> <td style="background-color: #f4a460;">Medium cutting</td> <td style="background-color: #f4a460;">2/200</td> <td style="background-color: #f4a460;">200</td> <td style="background-color: #f4a460;">70</td> <td style="background-color: #f4a460;">30</td> </tr> <tr> <td style="background-color: #f4a460;">Heavy cutting</td> <td style="background-color: #f4a460;">1/100</td> <td style="background-color: #f4a460;">300</td> <td style="background-color: #f4a460;">70</td> <td style="background-color: #f4a460;">10</td> </tr> </tbody> </table> <p>Sliding resistance = (300 + 400)•0.1 = 70 kgf</p>	Calculation Items Different Operations	Speed/rotations	Cutting resistance	Sliding resistance	Time used	Fast feed	10m/min/1000min ⁻¹	0 kgf	70 kgf	10 %	Light cutting	6/600	100	70	50	Medium cutting	2/200	200	70	30	Heavy cutting	1/100	300	70	10
Calculation Items Different Operations	Speed/rotations	Cutting resistance	Sliding resistance	Time used																																															
Fast feed	m/min/min ⁻¹	kgf	kgf	%																																															
Light cutting	/																																																		
Medium cutting	/																																																		
Heavy cutting	/																																																		
Calculation Items Different Operations	Speed/rotations	Cutting resistance	Sliding resistance	Time used																																															
Fast feed	10m/min/1000min ⁻¹	0 kgf	70 kgf	10 %																																															
Light cutting	6/600	100	70	50																																															
Medium cutting	2/200	200	70	30																																															
Heavy cutting	1/100	300	70	10																																															

Key Points for Ball Screws Selection	Calculation for Ball Screws Selection
<p>2. Ball screw lead ℓ(mm)</p> $\ell = \frac{\text{Feeding speed (m/min)} \cdot 1000}{\text{Max. Rotating speed (min}^{-1}\text{) of motor}} \text{ (mm)}$	<p>2. Ball screw lead ℓ(mm)</p> $\ell = \frac{10000}{1000} = 10 \text{ (mm)}$ <p>Minimal disassembly = $\frac{10 \text{ mm}}{1000 \text{ stroke}}$ = 0.01 mm/stroke</p>
<p>3. Computation of average load P_e (kgf)</p> $P_e = \left[\frac{P_1^3 n_1 t_1 + P_2^3 n_2 t_2 + \dots + P_n^3 n_n t_n}{n_1 t_1 + n_2 t_2 + \dots + n_n t_n} \right]^{\frac{1}{3}}$ $P_e = \frac{2P_{\max} + P_{\min}}{3}$ $P_e \cong 0.65 P_{\max}$ $P_e \cong 0.75 P_{\max}$	<p>3. Computation of average load P_e (kgf)</p> $P_e = \left[\frac{70^3 \cdot 1000 \cdot 10 + 170^3 \cdot 600 \cdot 50 + 270^3 \cdot 200 \cdot 30 + 370^3 \cdot 100 \cdot 10}{1000 \cdot 10 + 600 \cdot 50 + 200 \cdot 30 + 100 \cdot 10} \right]^{\frac{1}{3}}$ $= \left[\frac{31.7 \cdot 10^{10}}{4.7 \cdot 10^4} \right]^{\frac{1}{3}}$ $\cong 189 \text{ kgf}$
<p>4. Average number of rotations n_m</p> $n_m = \frac{n_1 t_1 + n_2 t_2 + \dots + n_n t_n}{100}$	<p>4. Average number of rotations n_m</p> $n_m = \frac{1000 \cdot 10 + 600 \cdot 50 + 200 \cdot 30 + 100 \cdot 10}{100}$ $= \frac{4.7 \cdot 10^4}{100} = 470 \text{ min}^{-1}$
<p>5. Calculation of required dynamic rated load C_a</p> $C_a = P_e \cdot f_s$	<p>5. Calculation of required dynamic rated load C_a</p> $C_a = 189 \cdot 5 = 945 \text{ (kgf)}$
<p>6. Calculation of required static rated load C_{oa}</p> $C_{oa} = P_{\max} \cdot f_s$	<p>6. Calculation of required static rated load C_{oa}</p> $C_{oa} = 369 \cdot 5 = 1845 \text{ (kgf)}$
<p>7. Selection of nut type</p> <p>$C_a > 945$ $C_{oa} > 1845$</p> <p>Select the nut types with basic dynamic rated load and and basic static rated load as specified above.</p>	<p>7. Selection of nut type</p> <p>Choose SFNI 2510 on the catalogue</p> <p>$C_a = 2954 \text{ (kgf)}$</p> <p>$C_{oa} = 7295 \text{ (kgf)}$</p>

1-9 Life Design

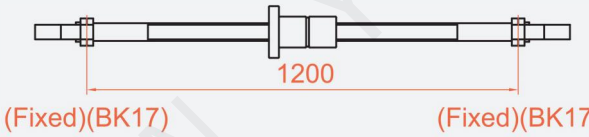
Key Points for Ball Screws Selection	Calculation for Ball Screws Selection
<p>8. Calculation of service life L_t (h)</p> $L_t = \frac{L}{60n} = \left(\frac{C_a}{P_e \cdot f_w} \right)^3 \cdot 10^6 \cdot \frac{1}{60n}$	<p>8. Calculation of service life L_t (h)</p> $L_t = \left(\frac{2954}{189 \cdot 2} \right)^3 \cdot 10^6 \cdot \frac{1}{60 \cdot 470} = 42544(\text{h})$
<p>9. Mounting distance between supporting bearings</p>	<p>9. Mounting distance between supporting bearings</p>  <p style="text-align: center;">(Fixed)(BK17) 1200 (Fixed)(BK17)</p>
<p>10. Determination of screw length</p> <p>Screw length = Maximal stroke + Nut length + Two reserved length at shaft end</p>	<p>10. Determination of screw length</p> <p>Screw length = 700 + 85 + 76 + 76 = 937 mm 937 mm < 1200 mm</p>
<p>11. Permissible axial load</p>	<p>11. Permissible axial load</p> <p>Omitted because of F-F support</p>
<p>12. Permissible revolution speed n and DN</p> $n = \alpha \cdot \frac{60\lambda^2}{2\pi L^2} \sqrt{\frac{E I g}{\gamma A}} = f \frac{d_r}{L^2} \cdot 10^7 (\text{rpm})$ <p>DN = Shaft dia • Maximal speed</p>	<p>12. Permissible revolution speed n and DN</p> $n = \frac{21.9 \cdot 21.86 \cdot 10^7}{1200^2} = 3324 \text{ min}^{-1} < n_{\text{max}}$ <p>DN = 25 • 1000 = 25000 < 50000</p>
<p>13. Countermeasure against thermal displacement</p> $\Delta \ell = \alpha \cdot \Delta t \cdot L$ <p>$\Delta \ell$: Thermal displacement α: Coefficient of thermal expansion Δt: Temperature rise (deg) at screw shaft L: Effective length of screw thread</p>	<p>13. Countermeasure against thermal displacement</p> <p>It is estimated there would be a temperature rise 2~5°C with the ball screws of the general machinery, take temperature rise of 2°C to compute the extension of ball screw.</p> $\Delta \ell = \alpha \cdot \Delta t \cdot L = 11.7 \cdot 10 \cdot 2 \cdot 700 \text{ mm}$ $\cong 0.016 \text{ mm}$ $F_p = \frac{E A \Delta \ell}{L}$ $= \frac{2.06 \cdot 10^4 \cdot \frac{\pi \cdot 21.86^2}{4} \cdot 0.016}{700}$ $\cong 177 (\text{kgf})$

Key Points for Ball Screws Selection	Calculation for Ball Screws Selection
<p>14. Rigidity</p> <p>(1) Axial rigidity K_s and displacement δ_s of screw shaft</p> $K_s = \frac{P}{\delta_s} \text{ (kgf/mm)}$ <p>P : Axial load (kgf)</p> $\delta_{SF} = \frac{PL}{4AE} \text{ (mm).....(with reference to page C21)}$ <p>(2) Axial rigidity K_N and displacement δ_s of nut</p> $\delta_{NS} = \frac{K}{\sin\beta} \left[\frac{Q^2}{d} \right]^{\frac{1}{3}} \cdot \frac{1}{\xi} \text{ (mm)}$ $Q = \frac{P}{n \cdot \sin\beta} \text{ (kgf)}$ $n = \frac{D_0 \pi m}{d} \text{ (each).....(with reference to page C22)}$ <p>(3) Axial rigidity K_B and displacement δ_B of bracing shaf</p> $K_B = \frac{P}{\delta_B} \text{ (kgf/mm).....(with reference to page C23)}$	<p>14. Rigidity</p> <p>Deviation can be corrected by estimating the temperature rise per extension of 0.016 mm, and taking into consideration of the pre-tension of 177 kgf.</p> <p>(1) Directional rigidity</p> $\delta_{SF} = \frac{PL}{4AE} = \frac{27 \cdot 1200}{4 \cdot \frac{\pi \cdot 21.86^2}{4} \cdot 2.06 \cdot 10^4}$ $= 0.00105 \text{ (mm)}$ $K_s = \frac{370}{0.00105} = 3.5 \cdot 10^5 \text{ kgf/mm}$ <p>(2) Rigidity of steel ball and nut groove</p> $n = \frac{26.62 \cdot \pi \cdot 4}{4.762} = 70$ $Q = \frac{370}{70 \sin 45^\circ} = 10$ $\delta_{NS} = \frac{0.00057}{\sin 45^\circ} \left(\frac{10^2}{4.762} \right)^{\frac{1}{3}} \cdot \frac{1}{0.7}$ $= 3.2 \cdot 10 \text{ mm}$ $K_N = \frac{370}{3.2 \cdot 10^{-3}} = 1.27 \cdot 10^5 \text{ kgf/mm}$ <p>(3) Rigidity of support bearings</p> <p>Where, nut rigidity 50 kgf/μm</p> $\delta_B = \frac{370}{51 \cdot 2} = 3.6 \mu\text{m}$ $K_B = \frac{370}{0.0036} = 1 \cdot 10^5 \text{ kgf/mm}$ <ul style="list-style-type: none"> $\delta_{TOTAL} = 1.05 + 3.2 + 3.6 = 7.85 \mu\text{m}$
<p>15. Confirmation of the ball screw life</p>	<p>15. Confirmation of the ball screw life</p> $L = 42544 \text{ (h)} > 18000 \text{ (h)}$

1-10 Cautions About Use of Ball Screws

Ball screw assemblies are delicate components. Therefore, extra care must be taken to prevent the ball track from damages that caused by edged component or tools. Meanwhile, to prevent steel ball fall out of the nut through the disassembly of screw and nut or over stroke, please be careful while operating. If the steel ball falls out, please contact with YOSO MOTION for further instruction. Do not attempt to reassemble, which might cause permanent damage to the ball screw.)

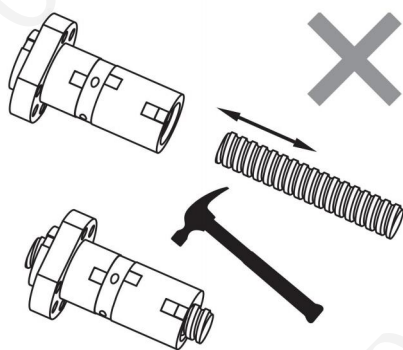

Fig 1.10.1 Error installation

If disassemble is required, please use a transfer pipe which has minor diameter than the screw diameter to transfer the nut to prevent falling out of the steel balls.

■ 1-10-1 Lubrication

Adequate lubrication must be provided when ball screw is used, insufficient lubrication will result in collision of metal, which leads to increase of friction and detrition, thus cause failure or shortening the service life.

Lubricants applied to ball screws can be divided into 2 types, namely lubricating oil and consistent grease. In general speaking, in respect of maintenance, consistent grease will lead to increase of dynamic friction torque linearly along with increase of rotating speed, hence oil lubrication is deemed the better way when speed exceeds 3-5 m/min; however, don't forget the fact that there have been examples that using grease has been capable of achieving speed of 10 m/min, with respect to the equipment.

In terms of equipments, there are some cheaper lubricant that can be used. In general, to fully utilize the function of ball screw, lubricating oil of 5m/minute is the best option to choose. In figure 1.10.1, we provide the standard of lubricating oil inspection and supplement interval. Before replenishing, please clean up the previous grease to continue.

Table 1.10.1 Inspection of lubrication and interval of refill

Method	Interval	Check Item	Replenish or Change Interval
Auto. Periodial oil supply	Weekly	Oil level, contamination	Add at each check, as required depending on tank level
Grease	Initially 2~3 months	Contamination on entry of chip	replenish yearly or according to the inspection result.
Oil bath	Daily	Oil level	To be determined according to consumption

■ 1-10-2 Dust Proof / Prevention

Any foreign matter or water, if entering to the ball screw, may increase friction and cause damage. For example, the entry of chips or cutting oil may be expected with machine tools according to the work environment. Where entry of foreign matter is anticipated, use a bellows or telescopic cover as shown in Fig 1.10.2, to cover the screw shaft completely.

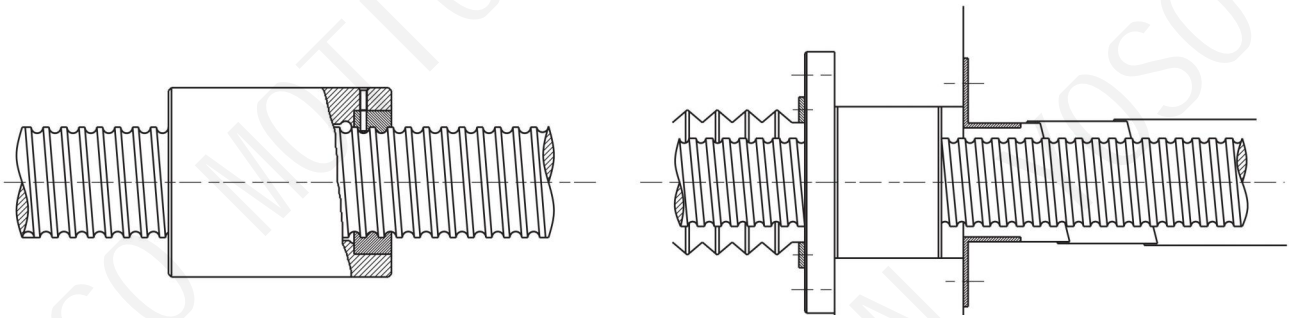

Fig 1.10.2 Dust proof Method by Telescopic Cover and Bellows

■ 1-10-3 Offset Load

When offset load phenomenon occurs, screw life and noise tend to be directly affected, which would usually be accompanied with hand feel of rough running. As the smoothness of single shaft and assembled ball screw might be different. In addition to single shaft's accuracy, the offset phenomenon was mostly occurred by failed assemble accuracy which is shown in Fig 1.10.3.

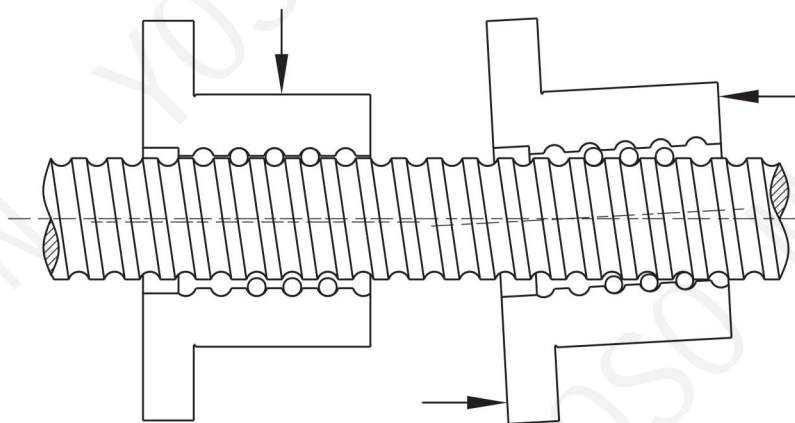

Fig 1.10.3 Offset Load

1-10 Cautions About Use of Ball Screws

■ 1-10-4 Assembling the Ball Screws

If rolled ball nut is shipped un-assembled please follow the procedure as below.

Table 1.10.2 Procedure

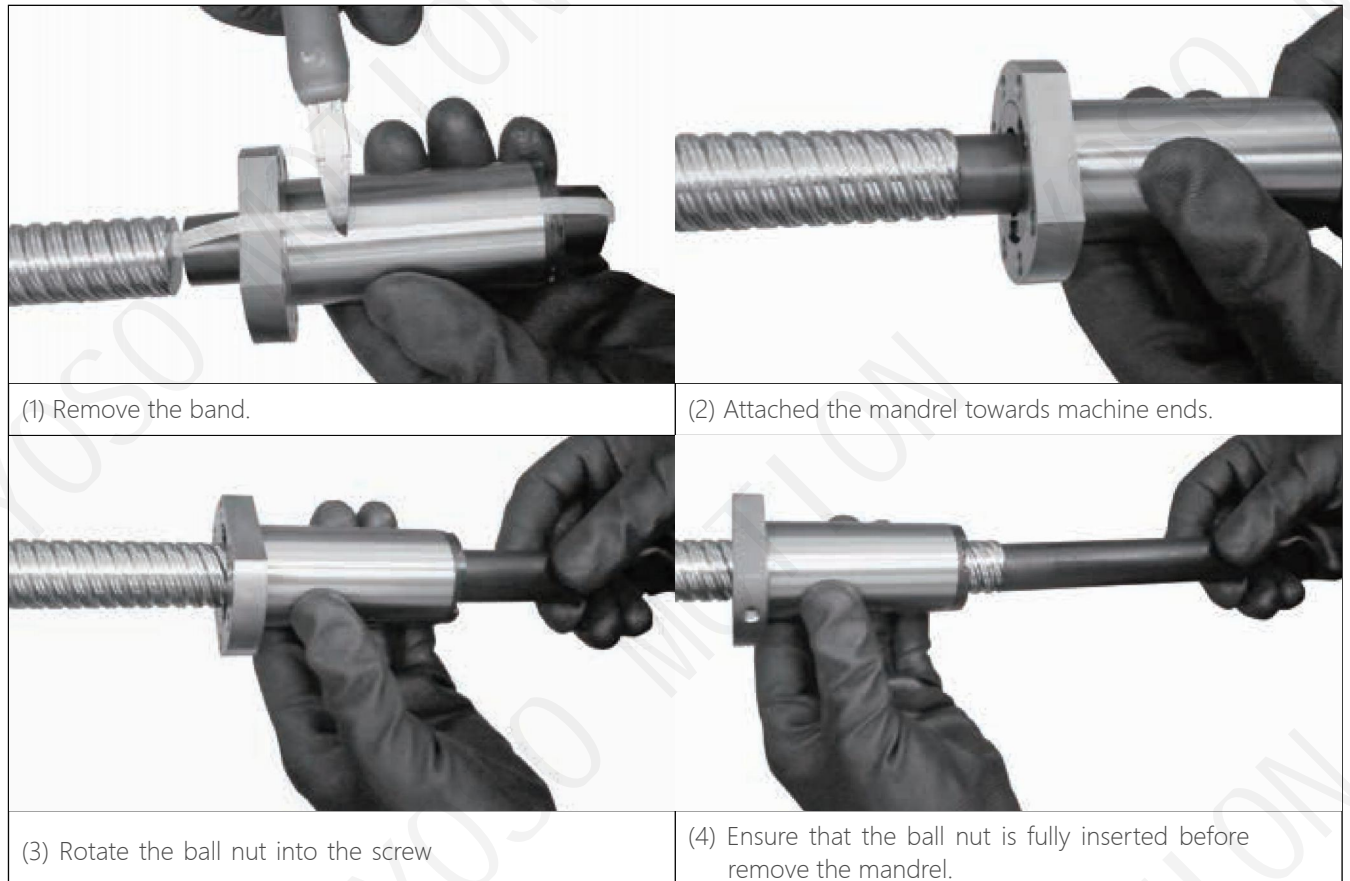

■ 1-10-5 Machining Specifications

(1) For the Ball Screws with internal or end cap type circulation ball nut, it is required to have at least one end with complete thread to the end of screw, it is also required to have the journal area is with diameter to be smaller than the diameter of thread root as Fig 1.10.4 shown.

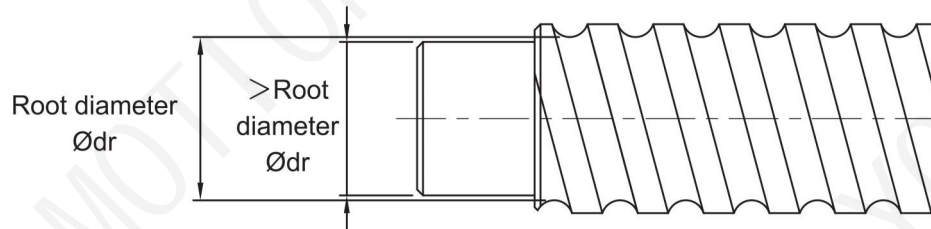

Fig 1.10.4 For Internal Circulation

(2) The thread on screw shaft are hardened by induction hardening. It shall cause about 10~20mm at both ends journal purpose. The unhardened area will be labeled.

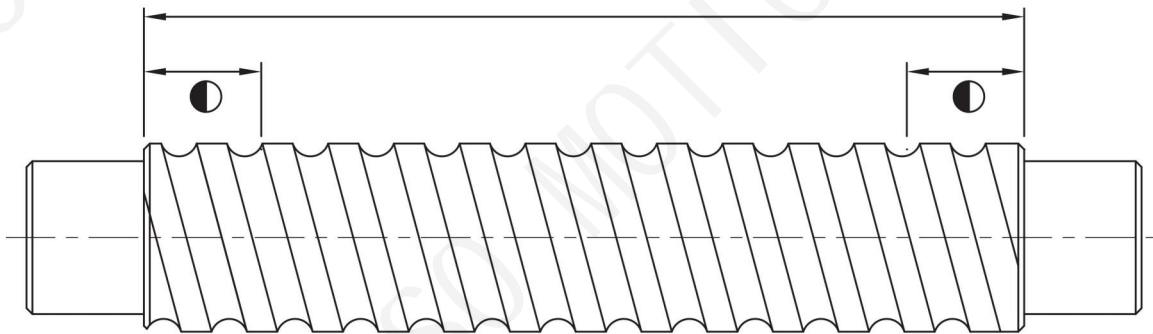

Fig 1.10.5 Harden Area

YOSO MOTION BALL SCREW

2-1 Nominal Model Code of Ball Screw

YS-SFU
R
025
05
T4
T
G
C5
-
600
-
P1
-
B2
+
N3
N3

①	②	⑤	⑦
Nominal Model	Threading Direction	Number of Turns (Turn•Row)	Product Code
S : Single nut	R : Right	Turn : T : 1	G : Ground
D : Double nut	L : Left	A : 1.5 (or 1.7/1.8)	F : Rolled
O : OFF set double nut		B : 2.5/2.8	
F : With flange	③	C : 3.5	⑧
C : Without flange	Nominal Diameter	D : 4.8	Accuracy Grade
NI : NI type nut	Unit : mm	ex : (2.5 x 2 = B2)	C0, C1, C2, C3, C5, C7, C10
NU : NU type nut			
H : H type nut	④	⑥	⑨
A : A type nut	Lead	Flange Type	Overall Length of Shaft
NH : NH nut (A solution for slide table)	Unit : mm	N : Not cutting	Unit : mm
Y : Y type nut		S : Single cutting	
V : V type nut		D : Double cutting	
U : DIN nut			
M : M type nut			
K : K type nut			

⑩	⑪
Axial Clearance and Preload Value	Number of Nut
P0, P1, P2, P3, P4	(Leave blank if only one nut is required) Ex : Install two nuts on a shaft B2

⑫	⑬
Nut Surface Treatment	Shaft Surface Treatment
S : Standard	S : Standard
B1 : Black Oxidation	B1 : Black Oxidation
N1 : Hard Chrome Plating	N1 : Hard Chrome Plating
P : Phosphating	P : Phosphating
N3 : Nickel Plating	N3 : Nickel Plating
N3 : Nickel Plating	N4 : Raydent
N5 : Chrome Plating	N5 : Chrome Plating

※ No symbol required when plating is not needed.

※ An inspection report is provided for ground ball screws with an accuracy higher than C5.

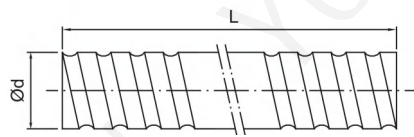

Fig 2.1.1 Screw Shaft Nominal Diameter

Table 2.1.1 Ground Ball Screw Specifications Ø4~32

Model No.			Accuracy Grade	Threading Direction R : Right L : Left	Number of Grooves	Standard Code of Shaft	Type of Nut
Ød	l	Da					
4	1	0.8	C7, C5, C3	R	1	SCR00401	K
6	1	0.8	C7, C5, C3	R	1	SCR00601	K
8	1	0.8	C7, C5, C3	R/L	1	SCR00801	K
	2	1.2	C7, C5, C3	R/L	1	SCR00802	K
	2.5	1.2	C7, C5, C3	R	1	SCR0082.5	K, BSH
10	2	1.2	C7, C5, C3	R/L	1	SCR01002	K, BSH
	4	2	C7, C5, C3	R	1	SCR01004	K, BSH
12	2	1.2	C7, C5, C3	R/L	1	SCR01202	K
	4	2.5	C7, C5, C3	R	1	SCR01204	U, BSH
	5	2.5	C7, C5, C3	R	1	SCR01205-A	V, U, BSH, H, A
	10	2.5	C7, C5, C3	R	2	SCR01210-B	V
14	2	1.2	C7, C5, C3	R/L	1	SCR01402	K
	4	2.5	C7, C5, C3	R	1	SCR01404	BSH
15	10	3.175	C7, C5, C3	R	1	SCR01510	V
	20	3.175	C7, C5, C3	R	1	SCR01520	V
16	2	1.2	C7, C5, C3	R/L	1	SCR01602	K
	4	2.381	C7, C5, C3	R	1	SCR01604(N)	V, I, U, BSH
	5	3.175	C7, C5, C3	R/L	1	SCR01605	V, NI, NU, BSH
	10	3.175	C7, C5, C3	R/L	2	SCR01610	V, NI, NU, BSH
	16	2.778	C7, C5, C3	R	2	SCR01616	Y
	32	2.778	C7, C5, C3	R	2	SCR01632	Y
20	2	1.2	C7, C5, C3	R	1	SCR02002	K
	4	2.381	C7, C5, C3	R	1	SCR02004(N)	V, I, U
	5	3.175	C7, C5, C3	R/L	1	SCR02005	V, NI, NU, BSH, H, A
	10	3.969	C7, C5, C3	R	1	SCR02010	V
	20	3.175	C7, C5, C3	R	2	SCR02020	V, Y, H, A
	40	3.175	C7, C5, C3	R	2	SCR02040	Y
25	2	1.2	C7, C5, C3	R	1	SCR02502	K
	4	2.381	C7, C5, C3	R	1	SCR02504(N)	I, U
	5	3.175	C7, C5, C3	R/L	1	SCR02505	V, NI, NU, BSH, H, A
	6	3.969	C7, C5, C3	R	1	SCR02506	V, U
	8	4.726	C7, C5, C3	R	1	SCR02508	V, U
	10	4.726	C7, C5, C3	R/L	1	SCR02510-A	NI, NU, BSH
	10	6.35	C7, C5, C3	R	1	SCR02510-B	V
	25	3.969	C7, C5, C3	R	2	SCR02525	Y
32	50	3.969	C7, C5, C3	R	2	SCR02550	Y
	4	2.381	C7, C5, C3	R	1	SCR03204(N)	V, I, U
	5	3.175	C7, C5, C3	R/L	1	SCR03205	V, NI, NU, M, H, A
	6	3.969	C7, C5, C3	R	1	SCR03206	V, U
	8	4.762	C7, C5, C3	R	1	SCR03208	V, U
	10	6.35	C7, C5, C3	R/L	1	SCR03210	V, NI, NU
	20	6.35	C7, C5, C3	R	1	SCR03220	V
	32	4.762	C7, C5, C3	R	2	SCR03232	Y
64	4.762	C7, C5, C3	R	2	SCR03264	Y	

YOSO MOTION BALL SCREW

2-1 Nominal Model Code of Ball Screw

Table 2.1.2 Standard Specifications Ø40~80

Model No.			Accuracy Grade	Threading Direction	Number of Grooves	Standard Code of Shaft	Type of Nut
Ød	l	Da		R : Right L : Left			
40	5	3.175	C7, C5, C3	R/L	1	SCR04005	V, NI, NU, H, A
	6	3.969	C7, C5, C3	R	1	SCR04006	V, NU
	8	4.762	C7, C5, C3	R	1	SCR04008	V, NU
	10	6.35	C7, C5, C3	R/L	1	SCR04010	V, NI, NU
	20	6.35	C7, C5, C3	R	2	SCR04020	V
	40	6.35	C7, C5, C3	R	2	SCR04040	Y
	80	6.35	C7, C5, C3	R	2	SCR04080	Y
50	5	3.175	C7, C5, C3	R	1	SCR05005	V, H, A
	10	6.35	C7, C5, C3	R/L	1	SCR05010	V, NI, NU
	20	9.525	C7, C5, C3	R	1	SCR05020	V
	50	7.938	C7, C5, C3	R	2	SCR05050	Y
	100	7.938	C7, C5, C3	R	2	SCR050100	Y
60	10	6.35	C7, C5, C3	R	1	SCR06310	V, NI, NU
	20	9.525	C7, C5, C3	R	1	SCR06320	V, NU
80	10	6.35	C7, C5, C3	R	1	SCR08010	V, NI, NU
	20	9.525	C7, C5, C3	R	1	SCR08020	V, NU

Table 2.1.3 H, A-type Specifications Ø16~50

Model No.			Accuracy Grade	Threading Direction	Number of Grooves	Standard Code of Shaft	Type of Nut
Ød	l	Da		R : Right L : Left			
12	10	2.5	C7, C5, C3	R	1	SSR01210	H, A
16	5	2.778	C7, C5, C3	R	1	SSR01605	H, A
	10	2.778	C7, C5, C3	R	1	SSR01610	H, A
	16	2.778	C7, C5, C3	R	1	SSR01616	H, A
	20	2.778	C7, C5, C3	R	1	SSR01620	H, A
20	10	3.175	C7, C5, C3	R	1	SSR02010	H, A
25	10	3.175	C7, C5, C3	R	1	SSR02510	H, A
	25	3.175	C7, C5, C3	R	1	SSR02525	H, A
32	10	3.969	C7, C5, C3	R	1	SSR03210	H, A
	20	3.969	C7, C5, C3	R	1	SSR03220	H, A
	32	6.35	C7, C5, C3	R	1	SSR03232	H, A
40	10	6.35	C7, C5, C3	R	1	SSR04010	H, A
	20	6.35	C7, C5, C3	R	1	SSR04020	H, A
	40	6.35	C7, C5, C3	R	1	SSR04040	H, A
50	10	6.35	C7, C5, C3	R	1	SSR05010	H, A
	20	6.35	C7, C5, C3	R	1	SSR05020	H, A
	50	6.35	C7, C5, C3	R	1	SSR05050	H, A

※The information is for specifications, if customized products are needed please contact Y O S O M O T I O N



2-2 Precision Ground Ball Screw Series

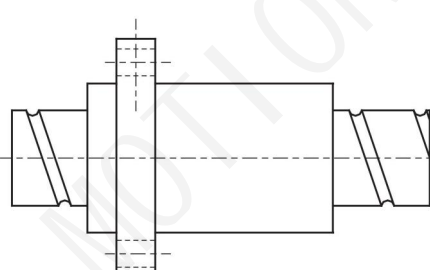
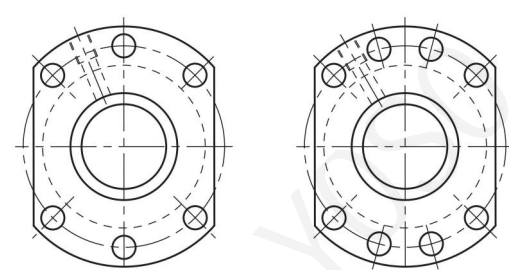
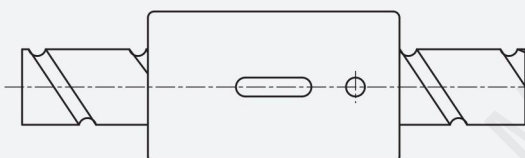
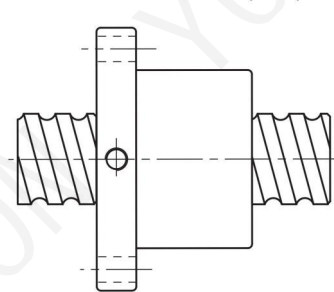
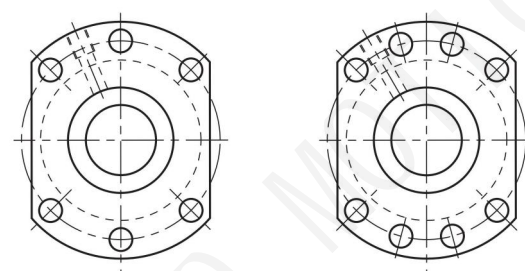
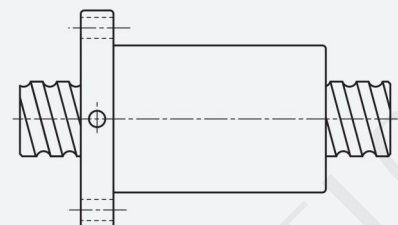
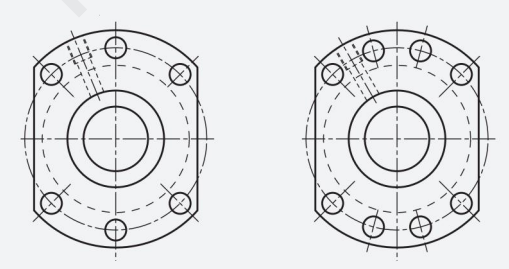

2-2-1 YOSO MOTION Nut of Precision Ground Ball Screw Type

	Nut Type	Flange Type
NH/HA (A solution for slide table/High Speed/Strong dust-proof type)	<p>YS-SFNH/SFH/SFA (DIN)</p>  <p>C44, 45</p>	 <p>$d \leq 32$ $d \geq 40$</p>
HC (A solution for slide table)	<p>YS-SCNH</p>  <p>C46</p>	No-Flange
NU (Strong dust-proof type)	<p>YS-SFNU/SFU (DIN)</p>  <p>C47</p>	 <p>$d \leq 32$ $d \geq 40$</p>
OFU/U (OFF set double nut)	<p>YS-OFU/DFU (DIN)</p>  <p>C48</p>	

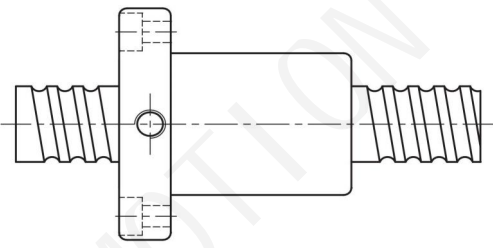
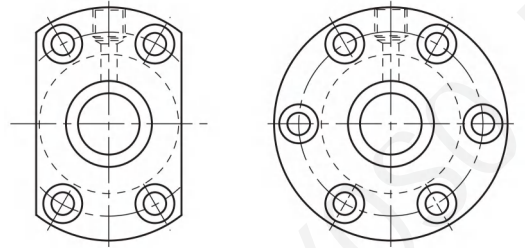
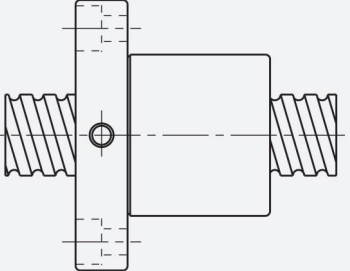
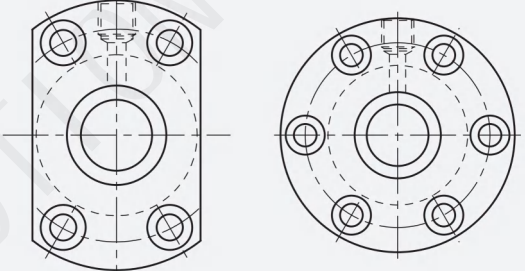
YOSO MOTION BALL SCREW

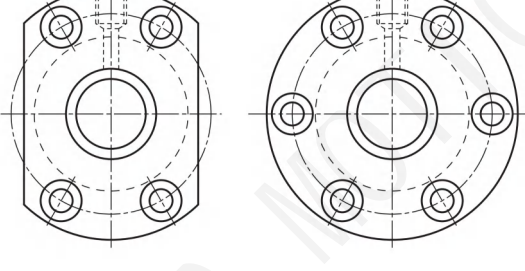
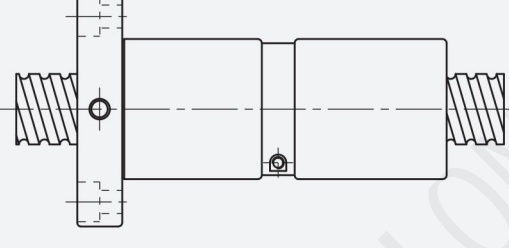
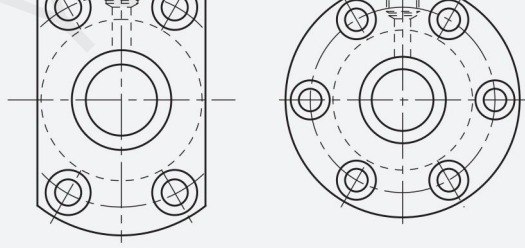
2-1 Precision Ground Ball Screw Series

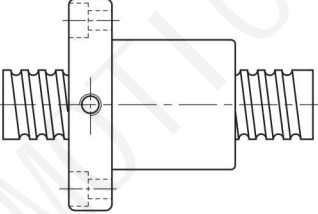
	Nut Type	Flange Type
\equiv (Strong dust-proof type)	YS-SFNI/SFI  C49	
\approx (Design for Milling)	YS-SFM  C49	
OFI/I (OFF set double nut)	YS-OFI/DFI  C50	
\approx (Design for Milling)	YS-DFM  C50	

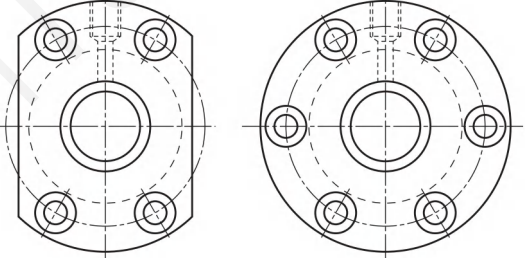
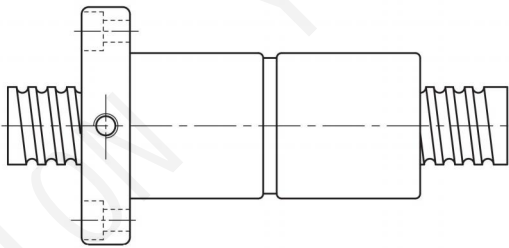
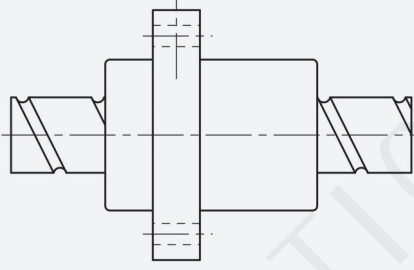
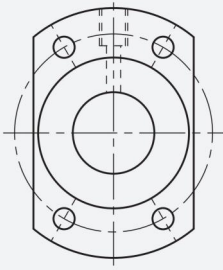
	Nut Type	Flange Type
<p>> (High Load External Circulation type)</p>	<p>YS-SFV</p>  <p>C51</p>	
<p>∇ (OFF set double nut)</p>	<p>YS-OFV</p>  <p>C52</p>	
<p>> (High Load External Circulation type)</p>	<p>YS-DFV</p>  <p>C52</p>	
<p>> (High DM-N Rating)</p>	<p>YS-SFY</p>  <p>C53</p>	

YOSO MOTION BALL SCREW

2-2 Precision Ground Ball Screw Series

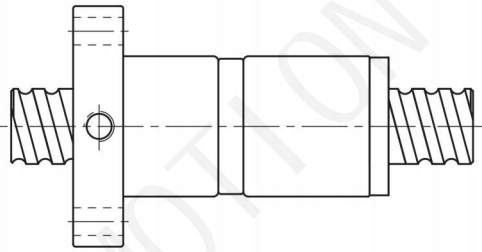
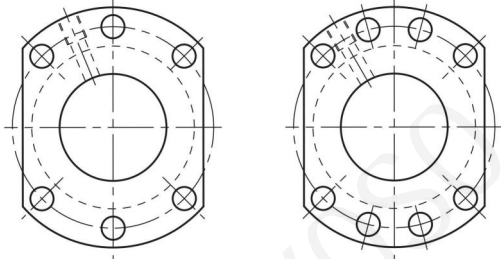
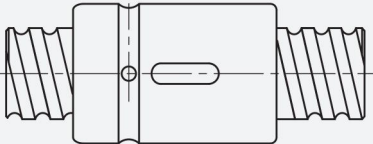
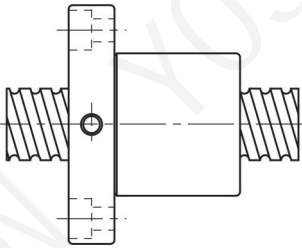
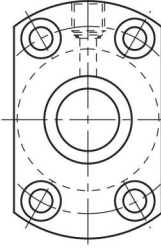
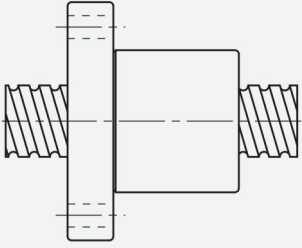
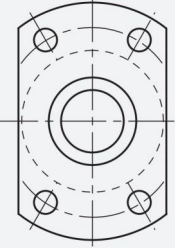
	Nut Type	Flange Type
∞ (High Speed / Low Noise type)	YS-DFS (DIN)  C54	 Model No. ≤ 3232 Model No. ≥ 4005
$\frac{1}{N}$ (Standard)	YS-SCNI/SCI  C55	No-Flange
κ (Miniature type)	YS-SFK  C56	 (SFK 01004) (SFK 02002) (SFK 02502)
	YS-SFK  C56	

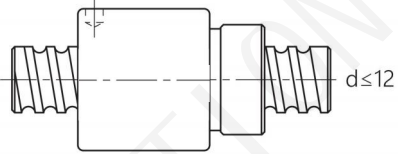
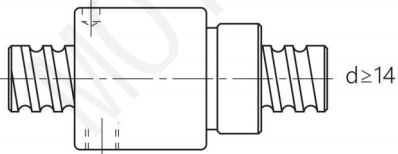
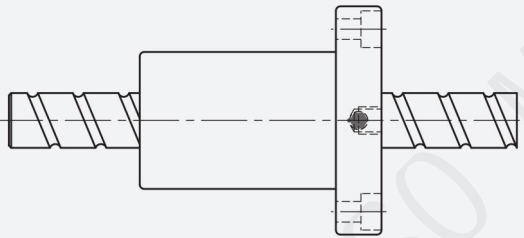
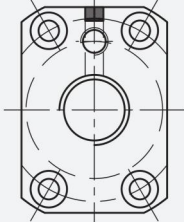
Nut Type		Flange Type
BSH	YS-BSH  $d \leq 12$	No-Flange
	 $d \geq 14$ C57	
XSV (Design for factory automation)	YS-XSV  $d \geq 14$ C58~62	

※The information is for specifications, if customized products is are needed please contact Y O S O M O T I O N

Table 2.2.1 Preload Chart

Preload	I, U, M-type	H, A-type	Y-type	V-type	BSH-type	K-type
P0						
P1	✓	✓	✓	✓	✓	✓
P2	✓	✓	✓	✓	✓	
P3	✓	✓	✓	✓	✓	
P4				✓		

YOSO MOTION BALL SCREW

2-2 Precision Ground Ball Screw Series

SFS Series Specifications

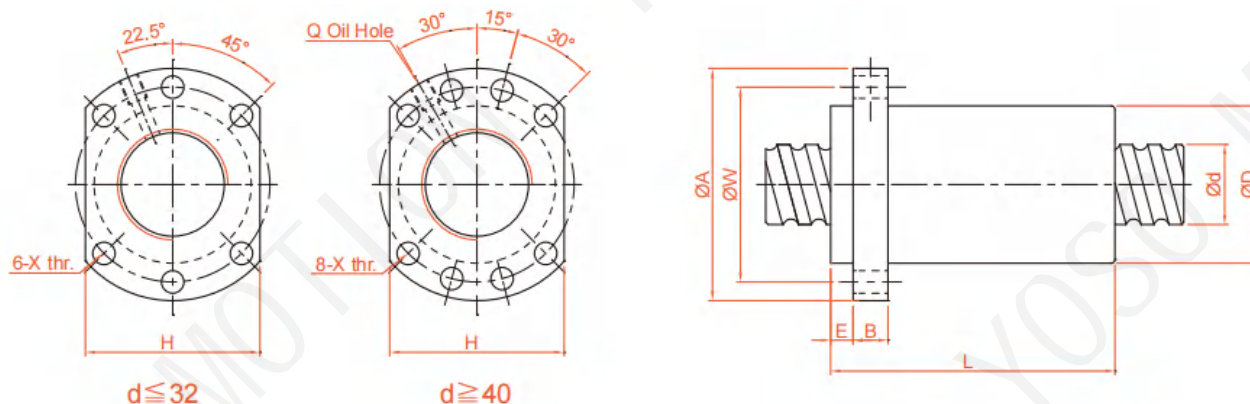

Unit : mm

Model No	d	l	Da	Dimension										Load Rating		K kgf/μm
				D	A	E	B	L	W	H	X	Q	n	Ca(kgf)	Coa(kgf)	
YS-SFS1205-2.8★	12	5	2.5	24	40	5	10	30	32	30	4.5		2.8×1	661	1316	19
YS-SFS1210-2.8★		10	2.5	24	40	5	10	42	32	30	4.5		2.8×1	642	1287	19
YS-SFS1605-3.8★	15	5	2.778	28	48	5	10	31	38	40	5.5	M6	3.8×1	1112	2507	30
YS-SFS1610-2.8★		10	2.778	28	48	5	10	42	38	40	5.5	M6	2.8×1	839	1821	23
YS-SFS1616-1.8★		16	2.778	28	48	5	10	43	38	40	5.5	M6	1.8×1	552	1137	14
YS-SFS1616-2.8★		16	2.778	28	48	5	10	59	38	40	5.5	M6	2.8×1	808	1769	22
YS-SFS1620-1.8★		20	2.778	28	48	5	10	50	38	40	5.5	M6	1.8×1	554	1170	14
YS-SFS1630-1.8★		30	2.778	28	48	7	10	70	38	40	5.5	M6	1.8×1	534	1195	14
YS-SFS2005-3.8★	20	5	3.175	36	58	7	10	33	47	44	6.6	M6	3.8×1	1484	3681	37
YS-SFS2010-3.8★		10	3.175	36	58	7	10	52	47	44	6.6	M6	3.8×1	1516	3833	40
YS-SFS2020-1.8★		20	3.175	36	58	7	10	52	47	44	6.6	M6	1.8×1	764	1758	19
YS-SFS2020-2.8★		20	3.175	36	58	7	10	72	47	44	6.6	M6	2.8×1	1118	2734	29
YS-SFS2505-3.8★	25	5	3.175	40	62	7	10	33	51	48	6.6	M6	3.8×1	1650	4658	43
YS-SFS2510-3.8★		10	3.175	40	62	7	12	52	51	48	6.6	M6	3.8×1	1638	4633	45
YS-SFS2525-1.8★		25	3.175	40	C	7	1	60	51	48	6.6	M6	1.8×1	843	2199	22
YS-SFS2525-2.8★		25	3.175	40	62	7	12	85	51	48	6.6	M6	2.8×1	1232	3421	34
YS-SFS3205-3.8	32	5	3.175	50	80	9	12	35	65	62	9	M6	3.8×1	1839	6026	51
YS-SFS3210-3.8		10	3.969	50	80	9	12	53	65	62	9	M6	3.8×1	2460	7255	55
YS-SFS3220-2.8		20	3.969	50	80	9	12	72	65	62	9	M6	2.8×1	1907	5482	43
YS-SFS3232-1.8		32	3.969	50	80	9	12	78	65	62	9	M6	1.8×1	1257	3426	27
YS-SFS3232-2.8		32	3.969	50	80	9	12	110	65	62	9	M6	2.8×1	1838	5329	42
YS-SFS4005-3.8	40	5	3.175	63	93	9	14	39	78	70	9	M8	3.8×1	2018	7589	60
YS-SFS4010-3.8		10	6.35	63	93	9	14	57	78	70	9	M8	3.8×1	5035	13943	67
YS-SFS4020-2.8		20	6.35	63	93	9	14	78	78	70	9	M8	2.8×1	3959	10715	54
YS-SFS4040-1.8		40	6.35	63	93	9	14	96	78	70	9	M8	1.8×1	2585	6648	34
YS-SFS4040-2.8		40	6.35	63	93	9	14	136	78	70	9	M8	2.8×1	3780	10341	52
YS-SFS5005-3.8		50	5	3.175	75	110	10.5	1L	42	93	85	11	M8	3.8×1	2207	9542
YS-SFS5010-3.8	10		6.35	75	110	10.5	18	57	93	85	11	M8	3.8×1	5638	17852	79
YS-SFS5020-3.8	20		6.35	75	110	10.5	18	98	93	85	11	M8	3.8×1	5749	18485	87
YS-SFS5050-1.8	50		6.35	75	110	10.5	18	117	93	85	11	M8	1.8×1	2946	8749	42
YS-SFS5050-2.8	50		6.35	75	110	10.5	18	167	93	85	11	M8	2.8×1	4308	13610	65

※ ★ Actuator type available.

※ Please contact YOSO MOTION if the marked types (●) are required.

YS-SFNH/SFH (DIN 69051 FORM B) Series Specifications

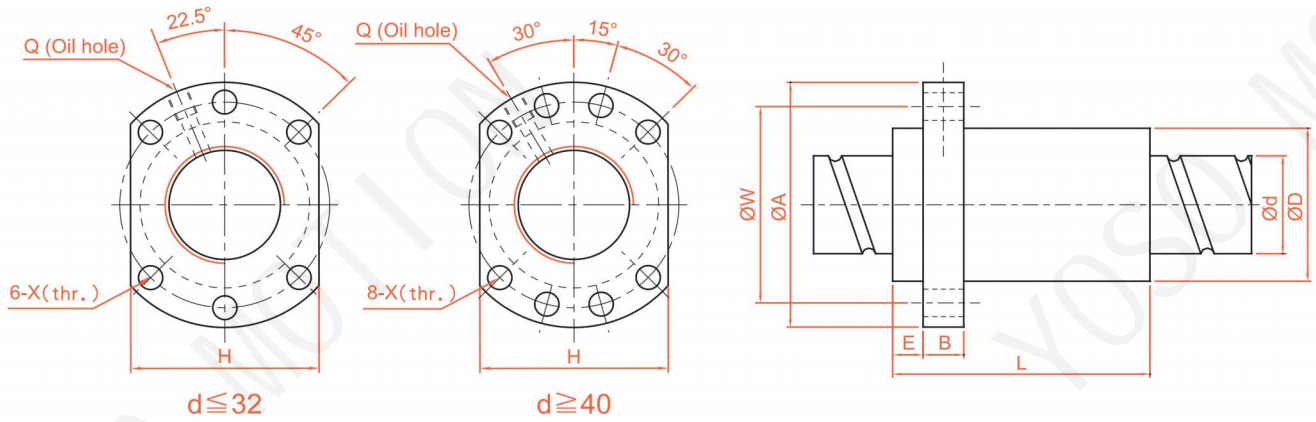

Model No.	d	l	Da	Dimension										Load Rating		K kgf/μm
				D	A	E	B	L	W	H	X	Q	n	Ca (kgf)	Coa (kgf)	
YS-SFH01205-2.8 ★	12	5	2.5	24	40	5	10	30	32	30	4.5		2.8x1	661	1316	19
YS-SFH01210-2.8 ★		10	2.5	24	40	5	10	45	32	30	4.5		2.8x1	642	1287	19
YS-SFH01605-3.8 ★	15	5	2.778	28	48	5	10	37	38	40	5.5	M6	3.8x1	1112	2507	30
YS-SFH01610-2.8 ★		10	2.778	28	48	5	10	45	38	40	5.5	M6	2.8x1	839	1821	23
YS-SFH01616-1.8		16	2.778	28	48	5	10	45	38	40	5.5	M6	1.8x1	552	1137	14
YS-SFH01616-2.8 ★		16	2.778	28	48	5	10	61	38	40	5.5	M6	2.8x1	808	1769	22
YS-SFH01620-1.8 ★		20	2.778	28	48	5	10	58	38	40	5.5	M6	1.8x1	554	1170	14
YS-SFH02005-3.8 ★		20	5	3.175	36	58	7	10	37	47	44	6.6	M6	3.8x1	1484	3681
YS-SFH02010-3.8 ★	10		3.175	36	58	7	10	55	47	44	6.6	M6	3.8x1	1516	3833	40
YS-SFH02020-1.8 ★	20		3.175	36	58	7	10	54	47	44	6.6	M6	1.8x1	764	1758	19
YS-SFH02020-2.8 ★	20		3.175	36	58	7	10	74	47	44	6.6	M6	2.8x1	1118	2734	29
YS-SFH02505-3.8 ★	25	5	3.175	40	62	7	10	37	51	48	6.6	M6	3.8x1	1650	4658	43
YS-SFH02510-3.8 ★		10	3.175	40	62	7	12	55	51	48	6.6	M6	3.8x1	1638	4633	45
YS-SFH02525-1.8 ★		25	3.175	40	62	7	12	64	51	48	6.6	M6	1.8x1	843	2199	22
YS-SFH02525-2.8 ★		25	3.175	40	62	7	12	89	51	48	6.6	M6	2.8x1	1232	3421	34
YS-SFH03205-3.8	32	5	3.175	50	80	9	12	37	65	62	9	M6	3.8x1	1839	6026	51
YS-SFH03210-3.8	31	10	3.969	50	80	9	12	57	65	62	9	M6	3.8x1	2460	7255	55
YS-SFH03220-2.8		10	3.969	50	80	9	12	76	65	62	9	M6	2.8x1	1907	5482	43
YS-SFH03232-1.8		32	3.969	50	80	9	12	80	65	62	9	M6	1.8x1	1257	3426	27
YS-SFH03232-2.8		32	3.969	50	80	9	12	112	65	62	9	M6	2.8x1	1838	5329	42
YS-SFH04005-3.8	40	5	3.175	63	93	9	15	42	78	70	9	M8	3.8x1	2018	7589	60
YS-SFH04010-3.8	38	10	6.35	63	93	9	14	60	78	70	9	M8	3.8x1	5035	13943	67
YS-SFH04020-2.8		20	6.35	63	93	9	14	80	78	70	9	M8	2.8x1	3959	10715	54
YS-SFH04040-1.8		40	6.35	63	93	9	14	98	78	70	9	M8	1.8x1	2585	6648	34
YS-SFH04040-2.8		40	6.35	63	93	9	14	138	78	70	9	M8	2.8x1	3780	10341	52
YS-SFH05005-3.8	50	5	3.175	75	110	10.5	15	42	93	85	11	M8	3.8x1	2207	9542	68
YS-SFH05010-3.8	48	10	6.35	75	110	10.5	18	60	93	85	11	M8	3.8x1	5638	17852	79
YS-SFH05020-3.8		20	6.35	75	110	10.5	18	100	93	85	11	M8	3.8x1	5749	18485	87
YS-SFH05050-1.8		50	6.35	75	110	10.5	18	120	93	85	11	M8	1.8x1	2946	8749	42
YS-SFH05050-2.8		50	6.35	75	110	10.5	18	170	93	85	11	M8	2.8x1	4308	13610	65

※ ★ Actuator type available (SFNH series).

YOSO MOTION BALL SCREW

2-2 Precision Ground Ball Screw Series

YS-SFA Series Specifications

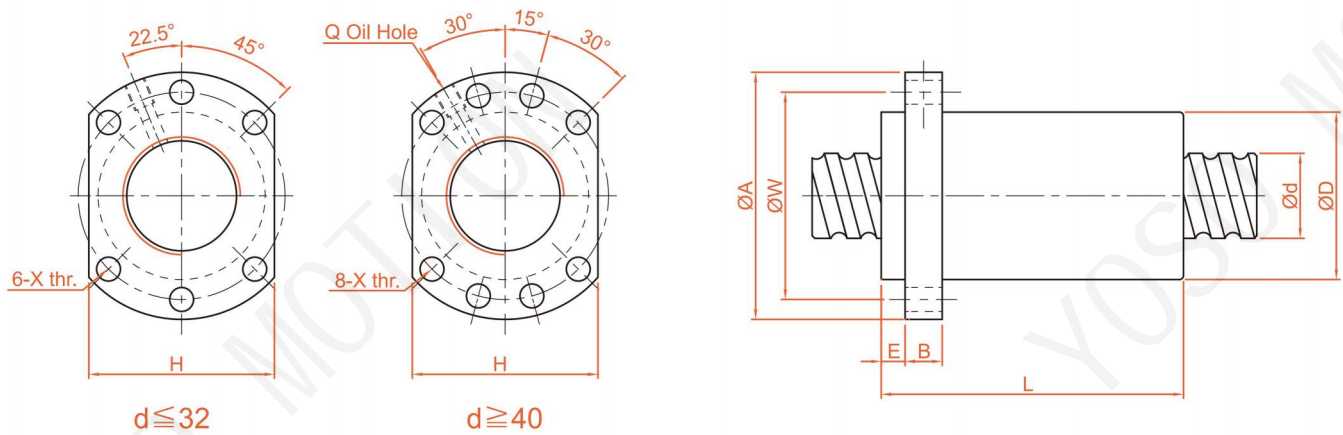

Model No.	d	l	Da	Dimension										Load Rating		K kgf/μm
				D	A	E	B	L	W	H	X	Q	n	Ca (kgf)	Coa (kgf)	
YS-SFA01205-2.8 ★	12	5	2.5	24	40	5	10	30	32	30	4.5		2.8x1	661	1316	19
YS-SFA01210-2.8 ★		10	2.5	24	40	5	10	45	32	30	4.5		2.8x1	642	1287	19
YS-SFA01605-3.8 ★	15	5	2.778	28	48	5	10	37	38	40	5.5	M6	3.8x1	1112	2507	30
YS-SFA01610-2.8 ★		10	2.778	28	48	5	10	45	38	40	5.5	M6	2.8x1	839	1821	23
YS-SFA01616-1.8		16	2.778	28	48	5	10	45	38	40	5.5	M6	1.8x1	552	1137	14
YS-SFA01616-2.8 ★		16	2.778	28	48	5	10	61	38	40	5.5	M6	2.8x1	808	1769	22
YS-SFA01620-1.8 ★		20	2.778	28	48	5	10	58	38	40	5.5	M6	1.8x1	554	1170	14
YS-SFA02005-3.8 ★	20	5	3.175	36	58	7	10	37	47	44	6.6	M6	3.8x1	1484	3681	37
YS-SFA02010-3.8 ★		10	3.175	36	58	7	10	55	47	44	6.6	M6	3.8x1	1516	3833	40
YS-SFA02020-1.8 ★		20	3.175	36	58	7	10	54	47	44	6.6	M6	1.8x1	764	1758	19
YS-SFA02020-2.8 ★		20	3.175	36	58	7	10	74	47	44	6.6	M6	2.8x1	1118	2734	29
YS-SFA02505-3.8 ★	25	5	3.175	40	62	7	10	37	51	48	6.6	M6	3.8x1	1650	4658	43
YS-SFA02510-3.8 ★		10	3.175	40	62	7	12	55	51	48	6.6	M6	3.8x1	1638	4633	45
YS-SFA02525-1.8 ★		25	3.175	40	62	7	12	64	51	48	6.6	M6	1.8x1	843	2199	22
YS-SFA02525-2.8 ★		25	3.175	40	62	7	12	89	51	48	6.6	M6	2.8x1	1232	3421	34
YS-SFA03205-3.8	32	5	3.175	50	80	9	12	37	65	62	9	M6	3.8x1	1839	6026	51
YS-SFA03210-3.8		10	3.969	50	80	9	12	57	65	62	9	M6	3.8x1	2460	7255	55
YS-SFA03220-2.8		10	3.969	50	80	9	12	76	65	62	9	M6	2.8x1	1907	5482	43
YS-SFA03232-1.8		32	3.969	50	80	9	12	80	65	62	9	M6	1.8x1	1257	3426	27
YS-SFA03232-2.8		32	3.969	50	80	9	12	112	65	62	9	M6	2.8x1	1838	5329	42
YS-SFA04005-3.8	40	5	3.175	63	93	9	15	42	78	70	9	M8	3.8x1	2018	7589	60
YS-SFA04010-3.8		10	6.35	63	93	9	14	60	78	70	9	M8	3.8x1	5035	13943	67
YS-SFA04020-2.8		20	6.35	63	93	9	14	80	78	70	9	M8	2.8x1	3959	10715	54
YS-SFA04040-1.8		40	6.35	63	93	9	14	98	78	70	9	M8	1.8x1	2585	6648	34
YS-SFA04040-2.8		40	6.35	63	93	9	14	138	78	70	9	M8	2.8x1	3780	10341	52
YS-SFA05005-3.8	50	5	3.175	75	110	10.5	15	42	93	85	11	M8	3.8x1	2207	9542	68
YS-SFA05010-3.8		10	6.35	75	110	10.5	18	60	93	85	11	M8	3.8x1	5638	17852	79
YS-SFA05020-3.8		20	6.35	75	110	10.5	18	100	93	85	11	M8	3.8x1	5749	18485	87
YS-SFA05050-1.8		50	6.35	75	110	10.5	18	120	93	85	11	M8	1.8x1	2946	8749	42
YS-SFA05050-2.8		50	6.35	75	110	10.5	18	170	93	85	11	M8	2.8x1	4308	13610	65

※ ★ Actuator type available.

YS-SCNH Series Specifications

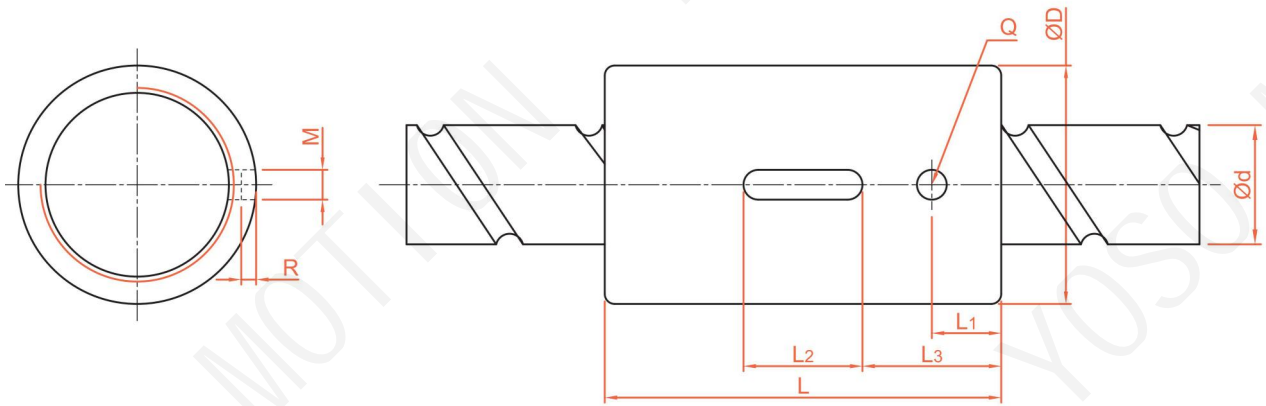

Unit : mm

Model No.	d	l	Da	Dimension									Load Rating		K kgf/μm
				D	L	L1	L2	L3	M	R	Q	n	Ca (kgf)	Coa (kgf)	
YS-SCNH01205-4.8	12	5	2.5	24	40	7	12	14	3	5	1.5	4.8x1	1011	2105	34
YS-SCNH01210-2.8		10	2.5	24	45	8	15	15	3	10	1.5	2.8x1	652	1287	19
YS-XCNH01210-1.8		10	2.5	24	40	10.5	12	14	3	10	1.5	1.8x1	439	827	33
YS-SCNH01605-5.8	15	5	2.778	28	45	7	20	12.5	5	5	3	5.8x1	1599	3827	49
YS-SCNH01610-2.8		10	2.778	28	45	7	20	12.5	5	10	3	2.8x1	839	1821	23
YS-SCNH01616-1.8		16	2.778	28	45	7	20	12.5	5	16	3	1.8x1	553	1137	18
YS-SCNH01620-1.8		20	2.778	28	58	10	20	19	5	20	3	1.8x1	554	1170	14
YS-SCNH02005-5.8	20	5	3.175	36	47	8	20	13.5	5	5	3	5.8x1	2134	5619	60
YS-SCNH02010-3.8		10	3.175	36	55	8	20	17.5	5	10	3	3.8x1	1516	3833	40
YS-SCNH02020-1.8		20	3.175	36	55	8	20	17.5	5	20	3	1.8x1	764	1758	19

YOSO MOTION BALL SCREW

2-2 Precision Ground Ball Screw Series

YS-SFNU/SFU (DIN 69051 FORM B) Series Specifications

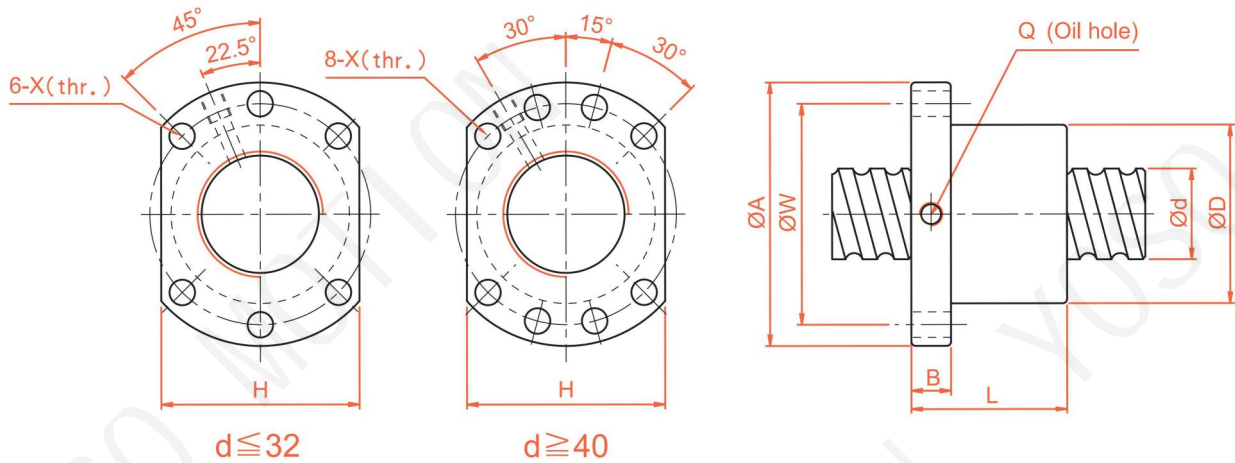

Model No.	d	l	Da	Dimension									Load Rating		K kgf/μm
				D	A	B	L	W	H	X	Q	n	Ca (kgf)	Coa (kgf)	
YS-SFNU01605-4*	16	5	3.175	28	48	10	45	38	40	5.5	M6	1x4	1380	3052	32
YS-SFNU01610-3*		10	3.175	28	48	10	57	38	40	5.5	M6	1x3	1103	2401	26
YS-SFNU02005-4*	20	5	3.175	36	58	10	51	47	44	6.6	M6	1x4	1551	3875	39
YS-SFNU02505-4*	25	5	3.175	40	62	10	51	51	48	6.6	M6	1x4	1724	4904	45
YS-SFNU02510-4*		10	4.762	40	62	12	80	51	48	6.6	M6	1x4	2954	7295	50
YS-SFNU03205-4*	32	5	3.175	50	80	12	52	65	62	9	M6	1x4	1922	6343	54
YS-SFNU03210-4*		10	6.35	50	80	12	85	65	62	9	M6	1x4	4805	12208	61
YS-SFNU04005-4*	40	5	3.175	63	93	14	55	78	70	9	M8	1x4	2110	7988	63
YS-SFNU04010-4*		10	6.35	63	93	14	88	78	70	9	M8	1x4	5399	15500	73
YS-SFNU05010-4*	50	10	6.35	75	110	16	88	93	85	11	M8	1x4	6004	19614	85
YS-SFNU05020-4		20	7.144	75	110	16	138	93	85	11	M8	1x4	7142	22588	94
YS-SFNU06310-4	63	10	6.35	90	125	18	93	108	95	11	M8	1x4	6719	25358	99
YS-SFNU06320-4		20	9.525	95	135	20	149	115	100	13.5	M8	1x4	11444	36653	112
YS-SFNU08010-4	80	10	6.35	105	145	20	93	125	110	13.5	M8	1x4	7346	31953	109
YS-SFNU08020-4		20	9.525	125	165	25	154	145	130	13.5	M8	1x4	12911	47747	138
YS-SFU01204-4	12	4	2.5	24	40	10	40	32	30	4.5		1x4	902	1884	26
YS-SFU01604-4	16	4	2.381	28	48	10	40	38	40	5.5	M6	1x4	973	2406	32
YS-SFU02004-4	20	4	2.381	36	58	10	42	47	44	6.6	M6	1x4	1066	2987	38
YS-SFU02504-4	25	4	2.381	40	62	10	42	51	48	6.6	M6	1x4	1180	3795	43
YS-SFU02506-4		6	3.969	40	62	10	54	51	48	6.6	M6	1x4	2318	6057	47
YS-SFU02508-4		8	4.762	40	62	10	63	51	48	6.6	M6	1x4	2963	7313	49
YS-SFU03204-4	32	4	2.381	50	80	12	44	65	62	9	M6	1x4	1296	4838	51
YS-SFU03206-4		6	3.969	50	80	12	57	65	62	9	M6	1x4	2632	7979	57
YS-SFU03208-4		8	4.762	50	80	12	65	65	62	9	M6	1x4	3387	9622	60
YS-SFU04006-4	40	6	3.969	63	93	14	60	78	70	9	M6	1x4	2873	9913	66
YS-SFU04008-4		8	4.762	63	93	14	67	78	70	9	M6	1x4	3712	11947	70
YS-SFU10020-4	100	20	9.525	150	202	30	180	170	155	17.5	M8	1x4	14303	60698	162

✕ ☆ Left helix available

2-2 Precision Ground Ball Screw Series

YS-OFU/DFU (DIN 69051 FORM B) Series Specifications

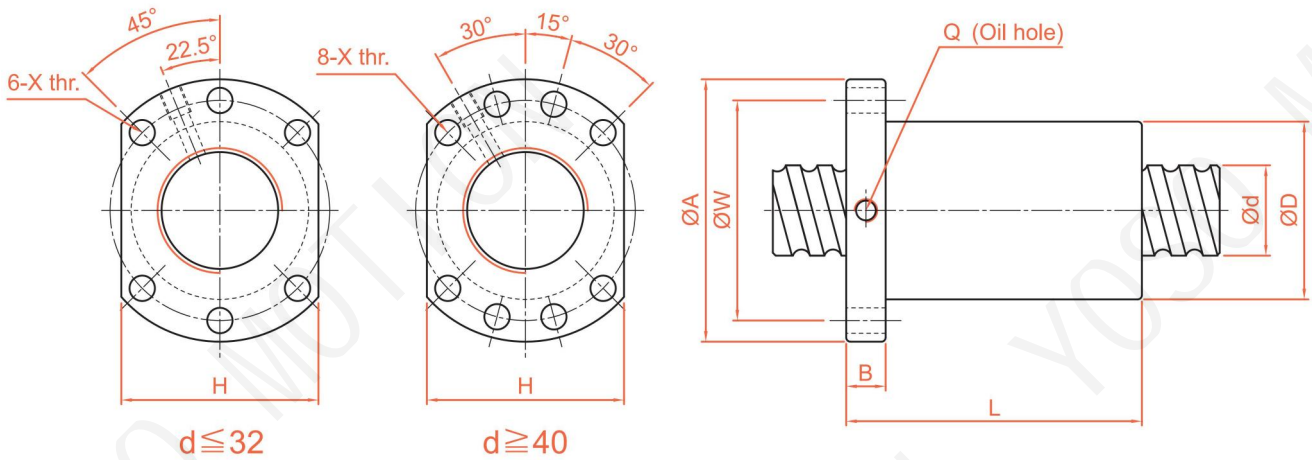

Model No.	d	l	Da	Dimension									Load Rating		K kgf/μm
				D	A	B	L	W	H	X	Q	n	Ca (kgf)	Coa (kgf)	
YS-OFU01605-4	16	5	3.175	28	48	10	45	38	40	5.5	M6	1x4	1380	3052	44
YS-OFU02005-4	20	5	3.175	36	58	10	51	47	44	6.6	M6	1x4	1551	3875	53
YS-OFU02505-4	25	5	3.175	40	62	10	51	51	48	6.6	M6	1x4	1724	4904	62
YS-OFU02510-4		10	4.762	40	62	12	80	51	48	6.6	M6	1x4	2954	7295	67
YS-OFU03205-4	32	5	3.175	50	80	12	52	65	62	9	M6	1x4	1922	6343	74
YS-OFU03210-4		10	6.35	50	80	12	85	65	62	9	M6	1x4	4805	12208	82
YS-OFU04005-4	40	5	3.175	63	93	14	55	78	70	9	M8	1x4	2110	7988	87
YS-OFU04010-4		10	6.35	63	93	14	88	78	70	9	M8	1x4	5399	15500	99
YS-OFU05010-4	50	10	6.35	75	110	16	88	93	85	11	M8	1x4	6004	19614	117
YS-OFU06310-4	63	10	6.35	90	125	18	93	108	95	11	M8	1x4	6719	25358	139
YS-OFU08010-4	80	10	6.35	105	145	20	93	125	110	13.5	M8	1x4	7346	31953	156

YOSO MOTION BALL SCREW

2-2 Precision Ground Ball Screw Series

Dimension Table of YS-DFU(DIN69051 Form B)Ball Screws

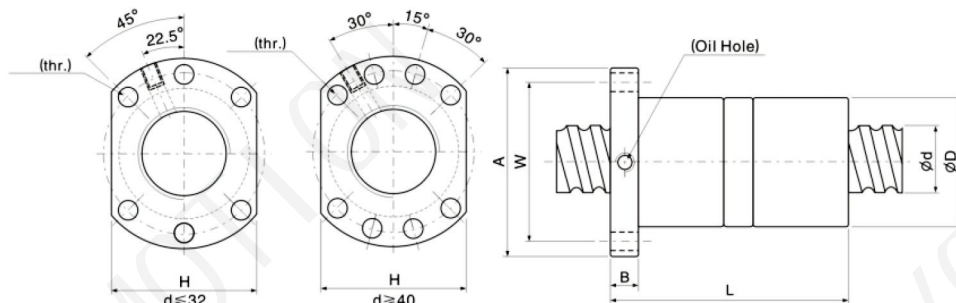

Unit : mm

Model No.	d	l	Da	Dimension											Load Rating		K kgf/μm
				D	A	B	L	W	H	X	Y	Z	Q	n	Ca (kgf)	Coa (kgf)	
YS-DFU 1604-4	16	4	2.381	28	48	10	80	38	40	5.5	-	-	M6	4	979	2412	24
YS-DFU 1605-4		5	3.175	28	48	10	100	38	40	5.5	-	-	M6	4	1386	3058	24
YS-DFU 1610-3		10	3.175	28	48	10	118	38	40	5.5	-	-	M6	3	1109	2407	19.5
YS-DFU 2004-4	20	4	2.381	36	58	10	80	47	44	6.6	-	-	M6	4	1072	2993	28.5
YS-DFU 2005-4		5	3.175	36	58	10	101	47	44	6.6	-	-	M6	4	1557	3881	29.25
YS-DFU 2504-4	25	4	2.381	40	62	10	80	51	48	6.6	-	-	M6	4	1188	3802	32.25
YS-DFU 2505-4		5	3.175	40	62	10	101	51	48	6.6	-	-	M6	4	1731	4911	33.75
YS-DFU 2506-4		6	3.969	40	62	10	105	51	48	6.6	-	-	M6	4	2318	6057	35.25
YS-DFU 2508-4		8	4.762	40	62	10	120	51	48	6.6	-	-	M6	4	2963	7313	36.75
YS-DFU 2510-4		10	4.762	40	62	12	145	51	48	6.6	-	-	M6	4	2961	7302	37.5
YS-DFU 3204-4	32	4	2.381	50	80	12	80	65	62	9	-	-	M6	4	1304	4846	38.25
YS-DFU 3205-4		5	3.175	50	80	12	102	65	62	9	-	-	M6	4	1930	6351	40.5
YS-DFU 3206-4		6	3.969	50	80	12	105	65	62	9	-	-	M6	4	2632	7979	42.75
YS-DFU 3208-4		8	4.762	50	80	12	122	65	62	9	-	-	M6	4	3387	9622	45
YS-DFU 3210-4		10	6.350	50	80	12	162	65	62	9	-	-	M6	4	4813	12216	45.75
YS-DFU 4005-4	40	5	3.175	63	93	14	105	78	70	9	-	-	M8	4	2118	7996	47.25
YS-DFU 4006-4		6	3.969	63	93	14	108	78	70	9	-	-	M6	4	2873	9913	49.5
YS-DFU 4008-4		8	4.762	63	93	14	132	78	70	9	-	-	M6	4	3712	11947	52.5
YS-DFU 4010-4		10	6.350	63	93	14	165	78	70	9	-	-	M8	4	5407	15508	54.75
YS-DFU 5010-4	50	10	6.350	75	110	16	171	93	85	11	-	-	M8	4	6012	19622	63.75
YS-DFU 5020-4		20	7.144	75	110	16	280	93	85	11	-	-	M8	4	7157	22603	70.5
YS-DFU 6310-4	63	10	6.350	90	125	18	182	108	95	11	-	-	M8	4	6728	25367	74.25
YS-DFU 6320-4		20	9.525	95	135	20	290	115	100	13.5	-	-	M8	4	11453	36662	84
YS-DFU 8010-4	80	10	6.350	105	145	20	182	125	110	13.5	-	-	M8	4	7356	31963	81.75
YS-DFU 8020-4		20	9.525	125	165	25	295	145	130	13.5	-	-	M8	4	12921	47757	103.5
YS-DFU10020-4	100	20	9.525	150	202	30	340	170	155	17.5	-	-	M8	4	14323	60718	121.5

YS-SFNI/SFI Series Specifications

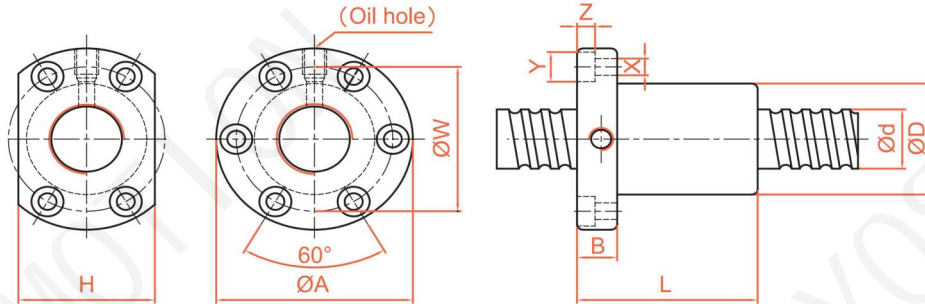

Unit : mm

Model No.	d	l	Da	Dimension											Load Rating		K kgf/μm
				D	A	B	L	W	H	X	Y	Z	Q	n	Ca (kgf)	Coa (kgf)	
YS-SFNI01605-4★	16	5	3.175	30	49	10	45	39	34	4.5	8	4.5	M6	1x4	1380	3052	33
YS-SFNI01610-3★		10	3.175	34	58	10	57	45	34	5.5	9.5	5.5	M6	1x3	1103	2401	27
YS-SFNI02005-4★	20	5	3.175	34	57	11	51	45	40	5.5	9.5	5.5	M6	1x4	1551	3875	39
YS-SFNI02505-4★	25	5	3.175	40	63	11	51	51	46	5.5	9.5	5.5	M8	1x4	1724	4904	45
YS-SFNI02510-4★		10	4.762	46	72	12	80	58	52	6.5	11	6.5	M6	1x4	2954	7295	51
YS-SFNI03205-4★	32	5	3.175	46	72	12	52	58	52	9	11	6.5	M8	1x4	1922	6343	52
YS-SFNI03210-4★		10	6.35	54	88	15	85	70	62	9	14	8.5	M8	1x4	4805	12208	62
YS-SFNI04005-4★	40	5	3.175	56	90	15	55	72	64	9	14	8.5	M8	1x4	2110	7988	59
YS-SFNI04010-4★		10	6.35	62	104	18	88	82	70	11	17.5	11	M8	1x4	5399	15500	72
YS-SFNI05010-4★	50	10	6.35	72	114	18	88	92	82	11	17.5	11	M8	1x4	6004	19614	83
YS-SFNI06310-4	63	10	6.35	85	131	22	93	107	95	14	20	13	M8	1x4	6719	25358	95
YS-SFNI08010-4	80	10	6.35	105	150	22	93	127	115	14	20	13	M8	1x4	7346	31953	109
YS-SFI01604-4	16	4	2.381	30	49	10	45	39	34	4.5	8	4.5	M6	1x4	973	2406	32
YS-SFI02004-4	20	4	2.381	34	57	11	46	45	40	5.5	9.5	5.5	M6	1x4	1066	2987	37
YS-SFI0205T-4		5.08	3.175	34	57	11	51	45	40	5.5	9.5	5.5	M6	1x4	1550	53875	39
YS-SFI02504-7★	25	4	2.381	40	63	11	46	51	46	5.5	9.5	5.5	M6	1x4	1180	3795	43
YS-SFI0255T-4		5.08	3.175	40	63	11	51	51	46	5.5	9.5	5.5	M8	1x4	1724	4903	45
YS-SFI03204-4	32	4	2.381	46	72	12	47	58	52	6.5	11	6.5	M6	1x4	1296	4838	49

SFM Series Specifications

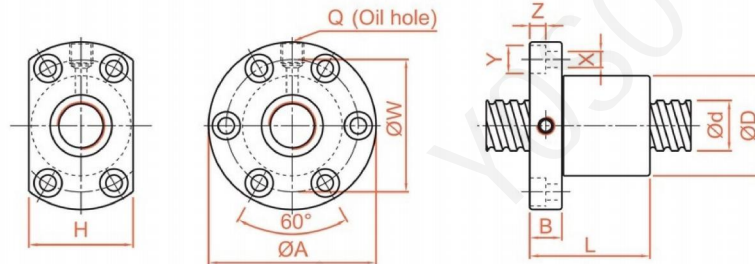

Unit : mm

Model No.	d	l	Da	Dimension											Load Rating		K kgf/μm
				D	A	B	L	W	H	X	Y	Z	Q	n	Ca (kgf)	Coa (kgf)	
YS-SFM03205-4★	32	5	3.175	48	74	12	52	60	60	6.5	11	6.5	M8	1x4	1922	6343	53
YS-SFM0325T-4★		5.08	3.175	48	74	12	53	60	60	6.5	11	6.5	M8	1x4	1922	6343	53

※ ☆ Left helix available

YOSO MOTION BALL SCREW

2-2 Precision Ground Ball Screw Series

YS-OFI/DFI Series Specifications

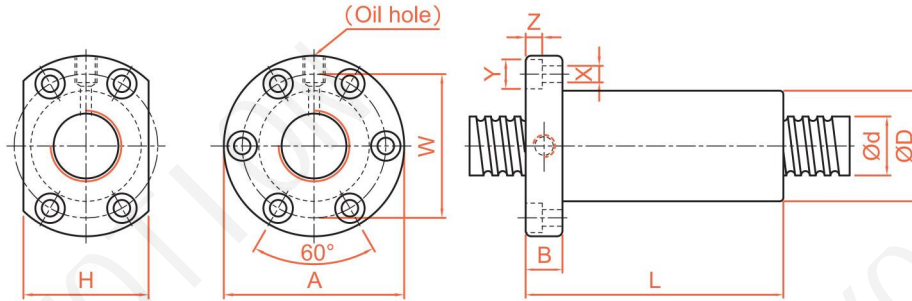

Unit : mm

Model No.	d	l	Da	Dimension										Load Rating		K kgf/μm	
				D	A	B	L	W	H	X	Y	Z	Q	n	Ca (kgf)		Coa (kgf)
YS-OFI01605-4	16	5	3.175	30	49	10	75	39	34	4.5	8	4.5	M6	1x8	1380	3052	44
YS-OFI02005-4	20	5	3.175	34	57	11	85	45	40	5.5	9.5	5.5	M6	1x8	1551	3875	52
YS-OFI02505-4	25	5	3.175	40	63	11	86	51	46	5.5	9.5	5.5	M8	1x8	1724	4904	62
YS-OFI02510-4		10	4.762	46	72	12	130	58	52	6.5	11	6.5	M6	1x8	2954	7295	68
YS-OFI03205-4	32	5	3.175	46	72	12	87	58	52	6.5	11	6.5	M8	1x8	1922	6343	72
YS-OFI03210-4		10	6.35	54	88	15	145	70	62	9	14	8.5	M8	1x8	4805	12208	83
YS-OFI04005-4	40	5	3.175	56	90	15	90	72	64	9	14	8.5	M8	1x8	2110	7988	84
YS-OFI04010-4		10	6.35	62	104	18	148	82	70	11	17.5	11	M8	1x8	5399	15500	99
YS-OFI05010-4	50	10	6.35	72	114	18	148	92	82	11	17.5	11	M8	1x8	6004	19614	115
YS-OFI06310-4	63	10	6.35	85	131	22	153	107	95	14	20	13	M8	1x8	6719	25358	135
YS-OFI08010-4	80	10	6.35	105	150	22	153	127	115	14	20	13	M8	1x8	7346	31953	156
YS-DFI01604-4	16	4	2.381	30	49	10	80	39	34	4.5	8	4.5	M6	1x4	973	2406	44
YS-DFI02004-4	20	4	2.381	34	57	11	80	45	40	5.5	9.5	5.5	M6	1x4	1066	2987	51
YS-DFI02504-4	25	4	2.381	40	63	11	80	51	46	5.5	9.5	5.5	M6	1x4	1180	3795	60
YS-DFI0255T-4		5.08	3.175	40	63	11	101	51	46	5.5	9.5	5.5	M8	1x4	1724	4903	62
YS-DFI03204-4	32	4	2.381	46	72	12	80	58	52	6.5	11	6.5	M6	1x4	1296	4838	69
YS-DFI03205T-4		5.08	3.175	46	72	12	102	58	52	6.5	11	6.5	M8	1x4	1922	6343	72

SFM Series Specifications

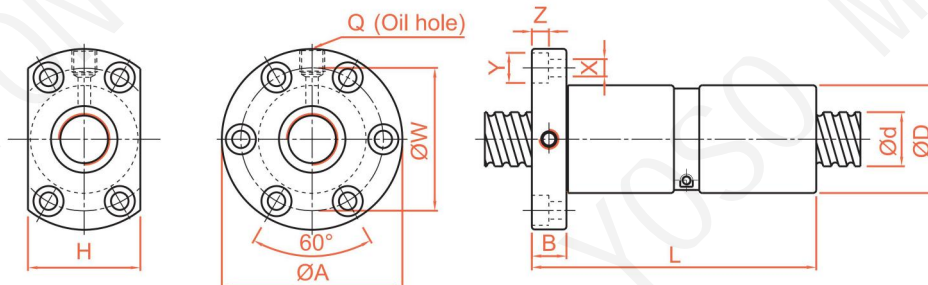

Unit : mm

Model No.	d	l	Da	Dimension										Load Rating		K kgf/μm	
				D	A	B	L	W	H	X	Y	Z	Q	n	Ca (kgf)		Coa (kgf)
YS-SFM03205-4★	32	5	3.175	48	74	12	102	60	60	6.5	11	6.5	M8	1x4	1922	6343	73
YS-SFM03205T-4★		5.08	3.175	48	74	12	102	60	60	6.5	11	6.5	M8	1x4	1922	6343	73

Note : For double ball screw nut order, please contact YOSO MOTION in advance.

※ ☆ Left helix available

YS-SFV Series Specifications

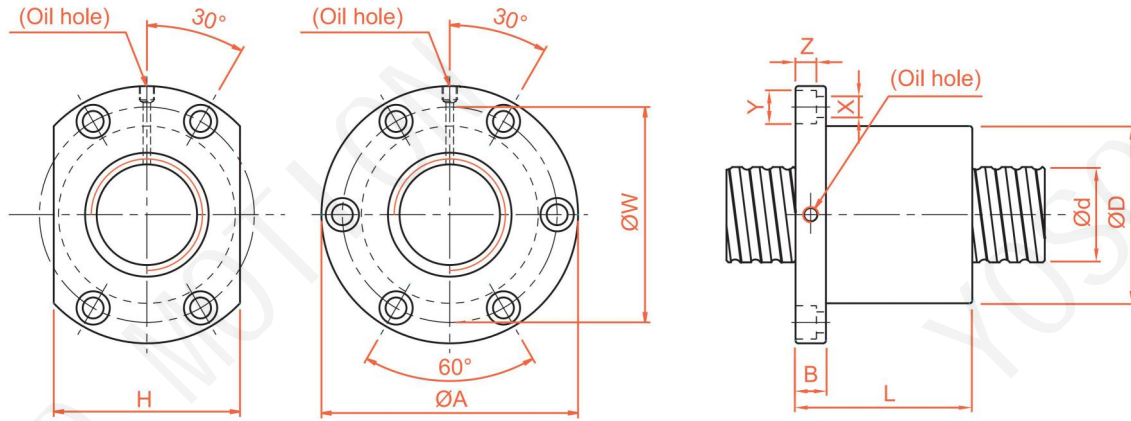

Unit : mm

Model No.	d	l	Da	Dimension										Load Rating		K kgf/μm	
				D	A	B	L	W	H	X	Y	Z	Q	n	Ca (kgf)		Coa (kgf)
YS-SFV01205-2.8	12	5	2.5	30	50	10	42	40	32	4.5	8	4.5	M6	2.8x1	661	1316	19
YS-SFV01210-2.7		10	2.5	30	50	10	53	40	32	4.5	8	4.5	M6	2.7x1	623	1241	18
YS-SFV01510-2.7	15	10	3.175	34	58	10	57	45	34	5.5	9.5	5.5	M6	2.7x1	972	2020	23
YS-SFV01604-3.8	15	4	2.381	34	57	11	45	45	34	5.5	9.5	5.5	M6	3.8x1	931	2285	31
YS-SFV01605-4.8		5	3.175	40	63	11	58	51	42	5.5	9.5	5.5	M6	4.8x1	1614	3662	40
YS-SFV01610-2.7		10	3.175	40	63	11	56	51	42	5.5	9.5	5.5	M6	2.7x1	1008	2161	24
YS-SFV02004-4.8	20	4	2.381	40	60	10	50	50	40	4.5	8	4	M6	4.8x1	1247	3584	45
YS-SFV02005-4.8		5	3.175	44	67	11	57	55	52	5.5	9.5	5.5	M6	4.8x1	1814	4650	47
YS-SFV02010-2.7		10	3.969	46	74	13	57	59	46	6.6	11	6.5	M6	2.7x1	1518	3398	30
YS-SFV02020-1.8		20	3.175	46	74	13	70	59	46	6.6	11	6.5	M6	1.8x1	764	1758	19
YS-SFV02505-4.8	25	5	3.175	50	73	11	55	61	52	5.5	9.5	5.5	M8	4.8x1	2017	5884	56
YS-SFV02506-4.8		6	3.969	53	76	11	62	64	58	5.5	9.5	5.5	M6	4.8x1	2711	7268	58
YS-SFV02508-4.8		8	4.762	56	85	13	70	71	64	6.5	11	6.5	M6	4.8x1	3466	8776	61
YS-SFV02510-2.7		10	6.35	68	102	15	70	84	82	9	14	8.5	M8	2.7x1	3040	6547	37
YS-SFV02525-1.8		25	3.175	50	73	13	83	61	52	5.5	9.5	5.5	M8	1.8x1	843	2199	22
YS-SFV03204-4.8	32	4	2.381	54	81	12	50	67	64	6.6	11	6.5	M6	4.8x1	1517	5806	62
YS-SFV03205-4.8		5	3.175	58	85	12	56	71	64	6.6	11	6.5	M8	4.8x1	2249	7612	66
YS-SFV03206-4.8		6	3.969	62	89	12	60	75	68	6.6	11	6.5	M8	4.8x1	3079	9575	70
YS-SFV03208-4.8		8	4.762	66	100	15	75	82	76	9	14	8.5	M8	4.8x1	3962	11547	74
YS-SFV03210-4.8		10	6.35	74	108	15	96	90	82	9	14	9	M8	4.8x1	5620	14649	76
YS-SFV03220-2.7		20	6.35	74	108	16	100	90	82	9	14	8.5	M8	2.7x1	3509	8644	46
YS-SFV04005-4.8	40	5	3.175	67	101	15	59	83	72	9	14	8.5	M8	4.8x1	2468	9586	76
YS-SFV04010-4.8		10	6.35	82	124	18	100	102	94	11	17.5	11	M8	4.8x1	6316	18600	90
YS-SFV04020-2.7		20	6.35	82	124	18	100	102	90	11	17.5	11	M8	2.7x1	3935	10893	56
YS-SFV05005-4.8	50	5	3.175	80	114	15	60	96	82	9	14	8.5	M8	4.8x1	2698	12053	87
YS-SFV05010-4.8		10	6.35	93	135	16	93	113	98	11	17.5	11	M8	4.8x1	7023	23537	106
YS-SFV05020-2.7		20	9.525	105	152	28	121	128	110	14	20	13	M8	2.7x1	7336	19700	68
YS-SFV06310-4.8	63	10	6.35	108	154	22	105	130	110	14	20	13	M8	4.8x1	7860	30430	126
YS-SFV06320-2.7		20	9.525	122	180	28	120	150	130	18	26	17.5	M8	2.7x1	8162	24741	80
YS-SFV08010-4.8	80	10	6.35	130	176	22	105	152	132	14	20	13	M8	4.8x1	8593	38344	145
YS-SFV08020-4.8		20	9.525	143	204	28	180	172	148	18	26	18	M8	4.8x1	15103	57296	168
YS-SFV08020-7.6		20	9.525	143	204	28	240	172	148	18	26	18	M8	3.8x2	22423	90719	260

YOSO MOTION BALL SCREW

2-2 Precision Ground Ball Screw Series

YS-OFV/DFV Series Specifications

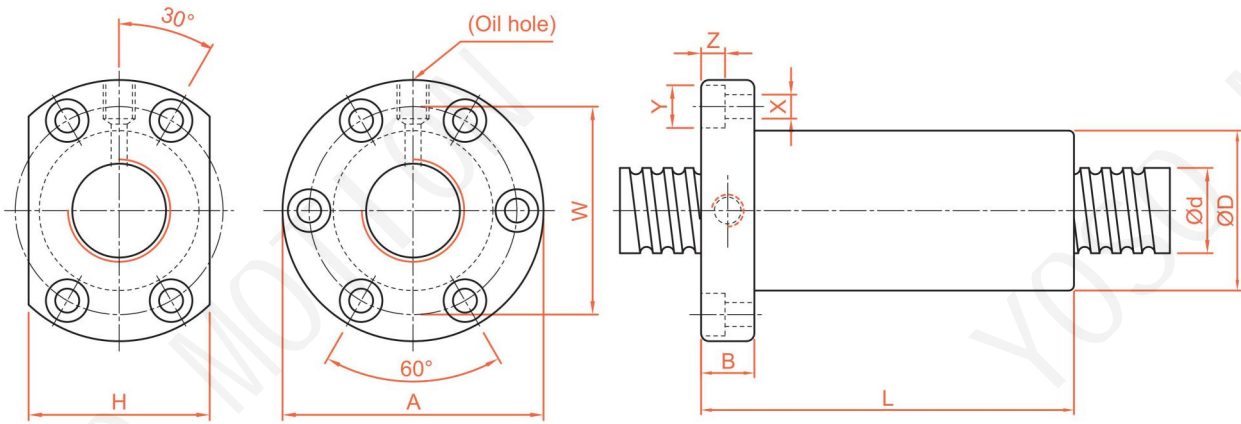

Model No.	d	l	Da	Dimension										Load Rating		K kgf/μm	
				D	A	B	L	W	H	X	Y	Z	Q	n	Ca (kgf)		Coa (kgf)
YS-OFV01605-4.8	16	5	3.175	40	63	11	100	51	42	5.5	9.5	5.5	M6	4.8x2	1614	3662	53
YS-OFV02005-4.8	20	5	3.175	44	67	11	102.5	55	52	5.5	9.5	5.5	M6	4.8x2	1814	4650	63
YS-OFV02505-4.8	25	5	3.175	50	73	11	96	61	52	5.5	9.5	5.5	M8	4.8x2	2017	5884	75
YS-OFV03205-4.8	32	5	3.175	58	85	12	98	71	64	6.6	11	6.5	M8	4.8x2	2249	7612	90
YS-OFV03210-4.8		10	6.35	74	108	15	166	90	82	9	14	9	M8	4.8x2	5620	14649	101
YS-OFV04005-4.8	40	5	3.175	67	101	15	100	83	72	9	14	8.5	M8	4.8x2	2468	9586	105
YS-OFV04010-4.8		10	6.35	82	124	18	174	102	94	11	17.5	11	M8	4.8x2	6316	18600	121
YS-OFV05010-4.8	50	10	6.35	93	135	16	167	113	98	11	17.5	11	M8	4.8x2	7023	23537	144
YS-OFV06310-4.8	63	10	6.35	108	154	22	177	130	110	14	20	13	M8	4.8x2	7860	30430	172
YS-OFV08010-4.8	80	10	6.35	130	176	22	178	152	132	14	20	13	M8	4.8x2	8593	38344	201
YS-DFV01510-2.7	15	10	3.175	34	58	10	107	45	34	5.5	9.5	5.5	M6	2.7x1	972	2020	30
YS-DFV01604-3.8	16	4	2.381	34	57	11	89	45	34	5.5	9.5	5.5	M6	3.8x1	931	2285	42
YS-DFV02004-4.8	20	4	2.381	40	60	10	94	50	40	4.5	8	4	M6	4.8x1	1247	3584	61
YS-DFV02010-2.7		10	3.969	46	74	13	117	59	46	6.6	11	6.5	M6	2.7x1	1518	3398	40
YS-DFV02506-4.8	25	6	3.969	53	76	11	116	64	58	5.5	9.5	5.5	M6	4.8x1	2711	7268	78
YS-DFV02508-4.8		8	4.762	56	85	13	134	71	64	6.5	11	6.5	M6	4.8x1	3466	8776	82
YS-DFV02510-2.7		10	6.35	68	102	15	130	84	82	9	14	8.5	M8	2.7x1	3040	6547	49
YS-DFV03204-4.8	32	4	2.381	54	81	12	94	67	64	6.6	11	6.5	M6	4.8x1	1517	5806	85
YS-DFV03206-4.8		6	3.969	62	89	12	114	75	68	6.6	11	6.5	M8	4.8x1	3079	9575	95
YS-DFV03208-4.8		8	4.762	66	100	15	139	82	76	9	14	8.5	M8	4.8x1	3962	11547	100
YS-DFV03220-2.7		20	6.35	74	108	16	200	90	82	9	14	8.5	M8	2.7x1	3509	8644	61
YS-DFV04020-2.7	40	20	6.35	82	124	18	200	102	90	11	17.5	11	M8	2.7x1	3935	10893	74
YS-DFV05005-4.8	50	5	3.175	80	114	15	115	96	82	9	14	8.5	M8	4.8x1	2698	12053	122
YS-DFV05020-2.7		20	9.525	105	152	28	221	128	110	14	20	13	M8	2.7x1	7336	19700	90
YS-DFV06320-2.7	63	20	9.525	122	180	28	220	150	130	18	26	17.5	M8	2.7x1	8162	24741	107
YS-DFV08020-4.8	80	20	9.525	143	204	28	340	172	148	18	26	18	M8	4.8x1	15103	57296	226
YS-DFV08020-7		20	9.525	143	204	28	460	172	148	18	26	18	M8	3.8x2	22423	90719	351

Note: For double ball screw nut order, please contact YOSO MOTION in advance.

YS-SFY Series Specifications

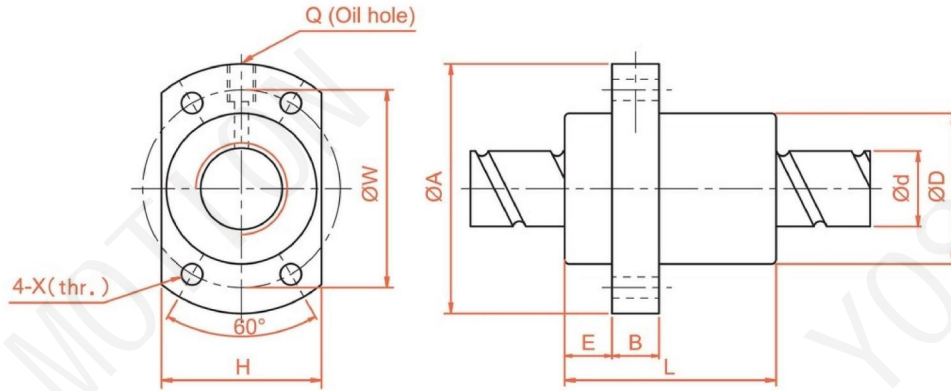

Unit : mm

Large Lead Model No.	d	l	Da	Dimension										Load Rating		K kgf/μm
				D	A	E	B	L	W	H	Xa	Q	n	Ca (kgf)	Coa (kgf)	
YS-SFY01616-3.6	16	16	2.778	32	53	10	10	45	42	34	4.5	M6	1.8x2	1073	2551	31
YS-SFY01616-5.6		16	2.778	32	53	10	10	61	42	34	4.5	M6	2.8x2	1568	3968	47
YS-SFY02020-3.6	20	20	3.175	39	62	13	10	54	50	41	5.5	M6	1.8x2	1387	3515	37
YS-SFY02020-5.6		20	3.175	39	62	13	10	72	50	41	5.5	M6	2.8x2	2029	5468	56
YS-SFY02525-3.6	25	25	3.969	47	74	15	12	64	60	49	6.6	M6	1.8x2	2074	5494	45
YS-SFY02525-5.6		25	3.969	47	74	15	12	89	60	49	6.6	M6	2.8x2	3032	8546	69
YS-SFY03232-3.6	32	32	4.762	58	92	17	12	80	74	60	9	M6	1.8x2	3021	8690	58
YS-SFY03232-5.6		32	4.762	58	92	17	12	110	74	60	9	M6	2.8x2	4417	13517	88
YS-SFY04040-3.6	40	40	6.35	73	114	19.5	15	99	93	75	11	M6	1.8x2	4831	14062	70
YS-SFY04040-5.6		40	6.35	73	114	19.5	15	139	93	75	11	M6	2.8x2	7065	21874	106
YS-SFY05050-3.6	50	50	7.938	90	135	21.5	20	117	112	92	14	M6	1.8x2	7220	21974	86
YS-SFY05050-5.6		50	7.938	90	135	21.5	20	167	112	92	14	M6	2.8x2	10558	34182	131
Twin Lead Model No.	d	l	Da	Dimension										Load Rating		K kgf/μm
				D	A	E	B	L	W	H	Xa	Q	n	Ca (kgf)	Coa (kgf)	
YS-SFY01632-1.6	16	32	2.778	32	53	10.1	10	42.5	42	34	4.5	M6	0.8x2	493	1116	11
YS-SFY01632-3.6		32	2.778	32	53	10.1	10	74.5	42	34	4.5	M6	1.8x2	989	2511	23
YS-SFY02040-1.6	20	40	3.175	39	62	13	10	48	50	41	5.5	M6	0.8x2	653	1597	15
YS-SFY02040-3.6		40	3.175	39	62	13	10	88	50	41	5.5	M6	1.8x2	1311	3592	30
YS-SFY02550-1.6	25	50	3.969	47	74	15	12	58	60	49	6.6	M6	0.8x2	976	2495	19
YS-SFY02550-3.6		50	3.969	47	74	15	12	108	60	49	6.6	M6	1.8x2	1960	5614	32
YS-SFY03264-1.6	32	64	4.762	58	92	17	12	71	74	60	9	M6	0.8x2	1374	3571	22
YS-SFY03264-3.6		64	4.762	58	92	17	12	135	74	60	9	M6	1.8x2	2759	8441	46
YS-SFY04080-1.6	40	80	6.35	73	114	19.5	15	90	93	75	11	M6	0.8x2	2273	6387	29
YS-SFY04080-3.6		80	6.35	73	114	19.5	15	170	93	75	11	M6	1.8x2	4566	14370	50
YS-SFY050100-1.6	50	100	7.938	90	135	21.5	20	111	112	92	14	M6	0.8x2	3398	9980	35
YS-SFY050100-3.6		100	7.938	90	135	21.5	20	211	112	92	14	M6	1.8x2	6824	22455	72

YOSO MOTION BALL SCREW

2-2 Precision Ground Ball Screw Series

YS-DFS (DIN 69051 FORM B) Series Specifications

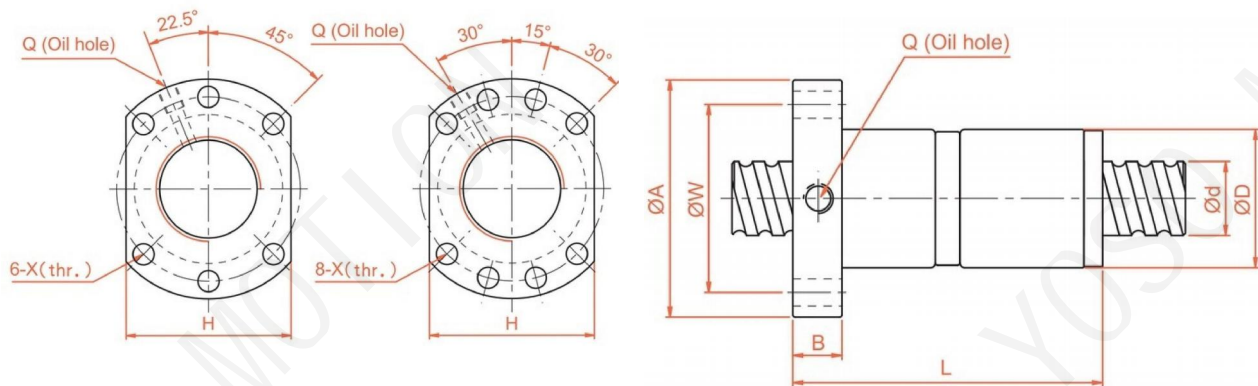

Unit : mm

Model No.	d	l	Da	Load Rating									Load Rating		K kgf/μm
				D	A	B	L	W	H	X	Q	n	Ca (kgf)	Coa (kgf)	
YS-DFS01605-3.8	15	5	2.778	28	48	10	73	38	40	5.5	M6	3.8x1	1112	2507	41
YS-DFS01610-2.8		10	2.778	28	48	10	97	38	40	5.5	M6	2.8x1	839	1821	31
YS-DFS02005-3.8	20	5	3.175	36	58	10	75	47	44	6.6	M6	3.8x1	1484	3681	50
YS-DFS02010-3.8		10	3.175	36	58	10	120	47	44	6.6	M6	3.8x1	1516	3833	53
YS-DFS02505-3.8	25	5	3.175	40	62	10	75	51	48	6.6	M6	3.8x1	1650	4658	59
YS-DFS02510-3.8		10	3.175	40	62	12	122	51	48	6.6	M6	3.8x1	1638	4633	61
YS-DFS03205-3.8	32	5	3.175	50	80	12	82	65	62	9	M6	3.8x1	1839	6026	71
YS-DFS03210-3.8	31	10	3.969	50	80	13	122	65	62	9	M6	3.8x1	2460	7255	75
YS-DFS03220-2.8		20	3.969	50	80	12	160	65	62	9	M6	2.8x1	1907	5482	58
YS-DFS04005-3.8	40	5	3.175	63	93	15	85	78	70	9	M8	3.8x1	2018	7589	83
YS-DFS04010-3.8	38	10	6.35	63	93	14	123	78	70	9	M8	3.8x1	5035	13943	91
YS-DFS04020-2.8		20	6.35	63	93	14	162	78	70	9	M8	2.8x1	3959	10715	73
YS-DFS05005-3.8	50	5	3.175	75	110	15	85	93	85	11	M8	3.8x1	2207	9542	96
YS-DFS05010-3.8	48	10	6.35	75	110	18	138	93	85	11	M8	3.8x1	5638	17852	109
YS-DFS05020-3.8		20	6.35	75	110	18	218	93	85	11	M8	3.8x1	5749	18485	116

Note: For double ball screw nut order, please contact YOSO MOTION in advance.

YS-SCNI/SCI Series Specifications

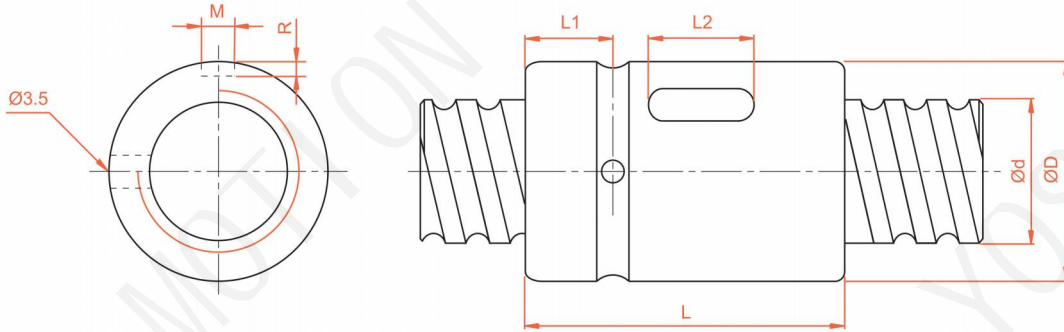

Unit : mm

Model No.	d	l	Da	Dimension							Load Rating		K kgf/μm
				D	L	L1	L2	M	R	n	Ca (kgf)	Coa (kgf)	
YS-SCNI 01605-4	16	5	3.175	30	45	9	20	5	3	1x4	1380	3052	33
YS-SCNI 02005-4	20	5	3.175	34	45	9	20	5	3	1x4	1551	3875	39
YS-SCNI 02505-4	25	5	3.175	40	45	9	20	5	3	1x4	1724	4904	45
YS-SCNI 02510-4		10	4.762	46	85	13	30	5	3	1x4	2954	7295	51
YS-SCNI 03205-4	32	5	3.175	46	45	9	20	5	3	1x4	1922	6343	52
YS-SCNI 03210-4		10	6.35	54	85	13	30	5	3	1x4	4805	12208	62
YS-SCNI 04005-4	40	5	3.175	56	45	9	20	5	3	1x4	2110	7988	59
YS-SCNI 04010-4		10	6.35	62	85	13	30	5	3	1x4	5399	15500	72
YS-SCNI 05010-4	50	10	6.35	72	85	13	30	5	3	1x4	6004	19614	83
YS-SCNI 06310-4	63	10	6.35	85	85	13	30	6	3.5	1x4	6719	25358	95
YS-SCNI 08010-4	80	10	6.35	105	85	13	30	8	4.5	1x4	7346	31953	109
YS-SCI 01604-4	16	4	2.381	30	40	9	15	3	1.5	1x4	973	2406	32
YS-SCI 02004-4	20	4	2.381	34	40	9	15	3	1.5	1x4	1066	2987	37
YS-SCI 02504-4	25	4	2.381	40	40	9	15	3	1.5	1x4	1180	3795	43
YS-SCI03204-4	32	4	2.381	46	40	9	15	3	1.5	1x4	1296	4838	49

Note: For double ball screw nut order, please contact YO SO MOTION in advance.

YOSO MOTION BALL SCREW

2-2 Precision Ground Ball Screw Series

YS-SFK Series Specifications

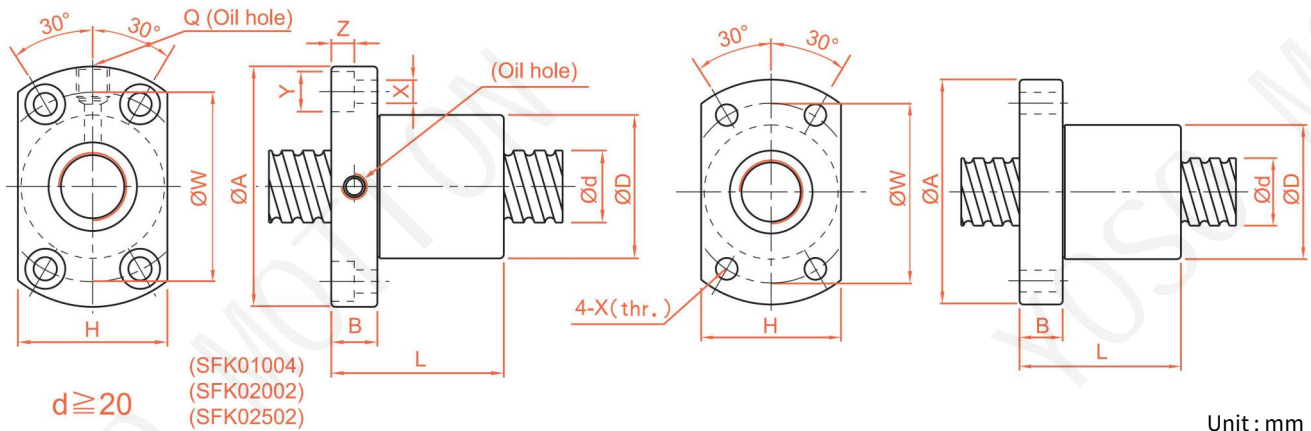

Unit : mm

Model No.	d	l	Da	Dimension											Ca (kgf)	Coa (kgf)	K kgf/ μ m
				D	A	B	L	W	H	X	Y	Z	Q	n			
YS-SFK00401	4	1	0.8	10	20	3	12	15	14	2.9	-	-	-	1x2	64	97	5
YS-SFK00601	6	1	0.8	12	24	3.5	15	18	16	3.4	-	-	-	1x3	111	224	9
YS-SFK00801★	8	1	0.8	14	27	4	16	21	18	3.4	-	-	-	1x4	161	403	14
YS-SFK00802★		2	1.2	14	27	4	16	21	18	3.4	-	-	-	1x3	222	458	13
YS-SFK0082.5		2.5	1.2	16	29	4	26	23	20	3.4	-	-	-	1x3	221	457	13
YS-SFK01002★	10	2	1.2	18	35	5	28	27	22	4.5	-	-	-	1x3	243	569	15
YS-SFK01004		4	2	26	46	10	34	36	28	4.5	8	4.5	M6	1x3	468	905	17
YS-SFK01202★	12	2	1.2	20	37	5	28	29	24	4.5	-	-	-	1x4	334	906	22
YS-SFK01402★	14	2	1.2	21	40	6	23	31	26	5.5	-	-	-	1x4	354	1053	24
YS-SFK01602★	16	2	1.2	25	43	10	40	35	29	5.5	-	-	M6	1x4	373	1200	26
YS-SFK02002	20	2	1.2	50	80	15	55	65	68	6.5	10.5	6	M6	1x6	581	2284	48
YS-SFK02502	25	2	1.2	50	80	13	43	65	68	6.5	10.5	6	M6	1x5	540	2381	46

※ ☆ Left helix available

Unit : mm

Model No.	d	l	Da	Dimension											Ca (kgf)	Coa (kgf)	K kgf/ μ m
				D	A	B	L	W	H	X	Y	Z	Q	n			
YS-XSUR01204T3D-02	12	4	2.5	24	40	6	28	32	25	3.5	-	-	-	1x3	704	1413	-
YS-XSUR01205T3D-00		5	2.5	22	37	8	39	29	24	4.5	-	-	-	1x3	702	1409	17

YS-BSHR Series Specifications

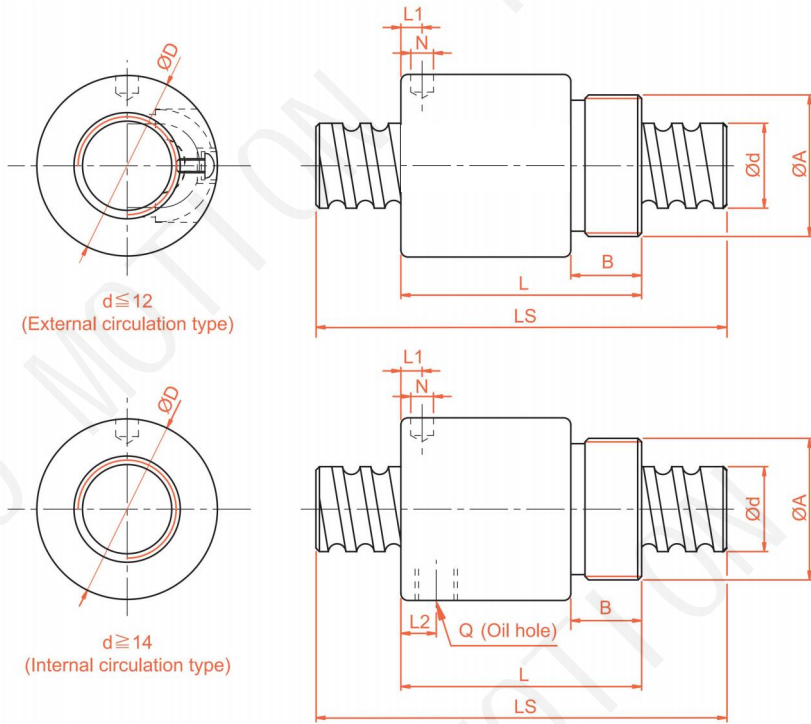

Unit : mm

Model No.	d	l	Da	Dimension								Ca (kgf)	Coa (kgf)	K (kgf/μm)	
				D	A	B	L	L1	N	L2	Q				n
YS-BSHR0082.5-2.5	8	2.5	1.2	17.5	M15x1P	7.5	23.5	10	3	-	-	2.5x1	189	381	11
YS-BSHR01002-3.5	10	2	1.2	19.5	M17x1P	7.5	22	3	3.2	-	-	3.5x1	277	664	17
YS-BSHR01004-2.5		4	2	25	M20x1P	10	34	3	3	-	-	2.5x1	400	754	14
YS-BSHR01204-3.5	12	4	2.5	25.5	M20x1P	10	34	13	3	-	-	3.5x1	804	1649	C
YS-BSHR01205-3.5		5	2.5	25.5	M20x1P	10	39	16.25	3	-	-	3.5x1	801	1644	24
YS-BSHR01404-3	14	4	2.5	32.1	M25x1.5P	10	35	11	3	-	-	1x3	748	1609	26
YS-BSHR01604-3	16	4	2.381	29	M22x1.5P	8	32	4	3.2	-	-	1x3	759	1804	24
YS-BSHR01605-3		5	3.175	32.5	M26x1.5P	12	42	19.25	3	-	-	1x3	1077	2289	25
YS-BSHR01610-2		10	3.175	32	M26x1.5P	12	50	3	4	3	M4	1x2	779	1601	14
YS-BSHR02005-3	20	5	3.175	38	M35x1.5P	15	45	20.3	3	-	-	1x3	1211	2906	30
YS-BSHR02505-4	25	5	3.175	43	M40x1.5P	19	69	32.11	3	8	M6	1x4	1724	4904	37
YS-BSHR02510-4		10	4.762	43	M40x1.5P	19	84	8	6	8	M6	1x4	2954	7295	41

※Standard ball nut from Ø8~Ø16 is assembled without wiper.

YOSO MOTION BALL SCREW

2-2 Precision Ground Ball Screw Series

YS-XSVR01210-01 Series Specifications (Finish Shaft Ends)

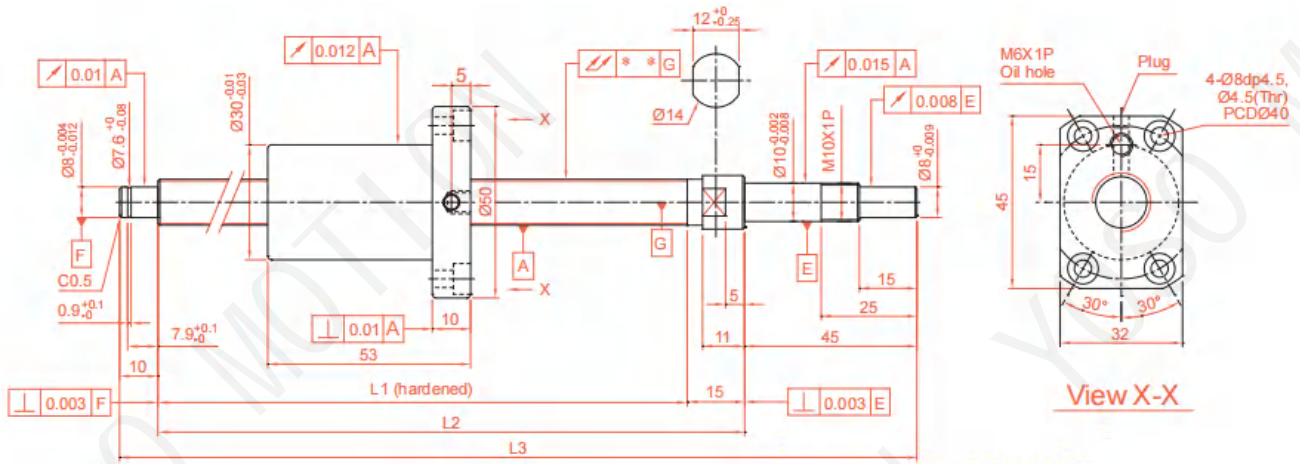

BCD	12.85
Ball Dia (mm)	2.5
Lead (mm)	10
No.of Turns	2.7x1
Lead Angle	13.91°
Threading Direction	R
Spring Force (kg)	0.1~0.2
Preload (kgf)	25
Dynamic Load Rating Ca (kgf)	411
Static Load Rating Coa (kgf)	638
Accuracy Grade	0.018

Unit : mm

Travel Length (mm)	Model No.	Shaft Length (mm)			Slant of Axle Center ↗
		L1	L2	L3	
100	XSVR01210B1DGC5-230-P1	160	175	230	0.035
150	XSVR01210B1DGC5-280-P1	210	225	280	0.035
250	XSVR01210B1DGC5-380-P1	310	325	380	0.050
350	XSVR01210B1DGC5-480-P1	410	425	480	0.060
450	XSVR01210B1DGC5-580-P1	510	525	580	0.075

YS-XSVR01510-00 Series Specifications (Finish Shaft Ends)

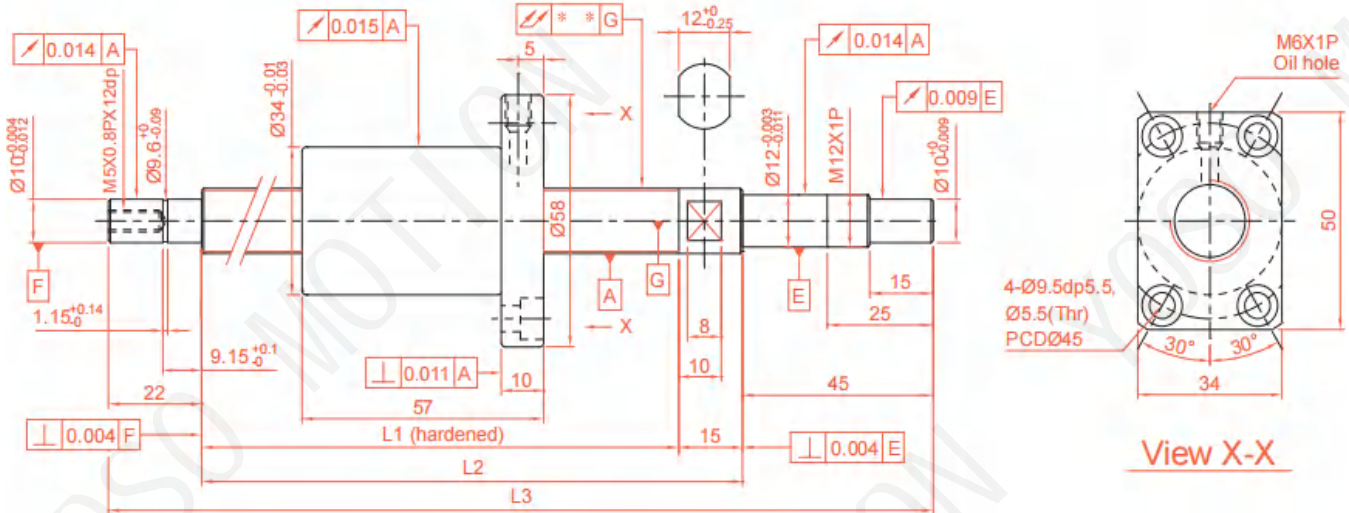

BCD	15.5
Ball Dia(mm)	3.175
Lead (mm)	10
No.of Turns	2.7x1
Lead Angle	11.6°
Threading Direction	R
Spring Force (kg)	0.1~0.3
Preload (kgf)	38
Dynamic Load Rating Ca(kgf)	611
Static Load Rating Coa(kgf)	950
Accuracy Grade	0.018

Unit : mm

Travel Length (mm)	Model No.	Shaft Length (mm)			Slant of Axle Center ∠
		L1	L2	L3	
100	XSVR01510B1DGC5-271-P1	189	204	271	0.025
150	XSVR01510B1DGC5-321-P1	239	254	321	0.035
200	XSVR01510B1DGC5-371-P1	289	304	371	0.035
250	XSVR01510B1DGC5-421-P1	339	354	421	0.040
300	XSVR01510B1DGC5-471-P1	389	404	471	0.040
350	XSVR01510B1DGC5-521-P1	439	454	521	0.050
400	XSVR01510B1DGC5-571-P1	489	504	571	0.050
450	XSVR01510B1DGC5-621-P1	539	554	621	0.050
500	XSVR01510B1DGC5-671-P1	589	604	671	0.065
550	XSVR01510B1DGC5-721-P1	639	654	721	0.065
600	XSVR01510B1DGC5-771-P1	689	704	771	0.065
700	XSVR01510B1DGC5-871-P1	789	804	871	0.085
800	XSVR01510B1DGC5-971-P1	889	904	971	0.085

YOSO MOTION BALL SCREW

2-2 Precision Ground Ball Screw Series

YS-XSVR01520-01 Series Specifications (Finish Shaft Ends)

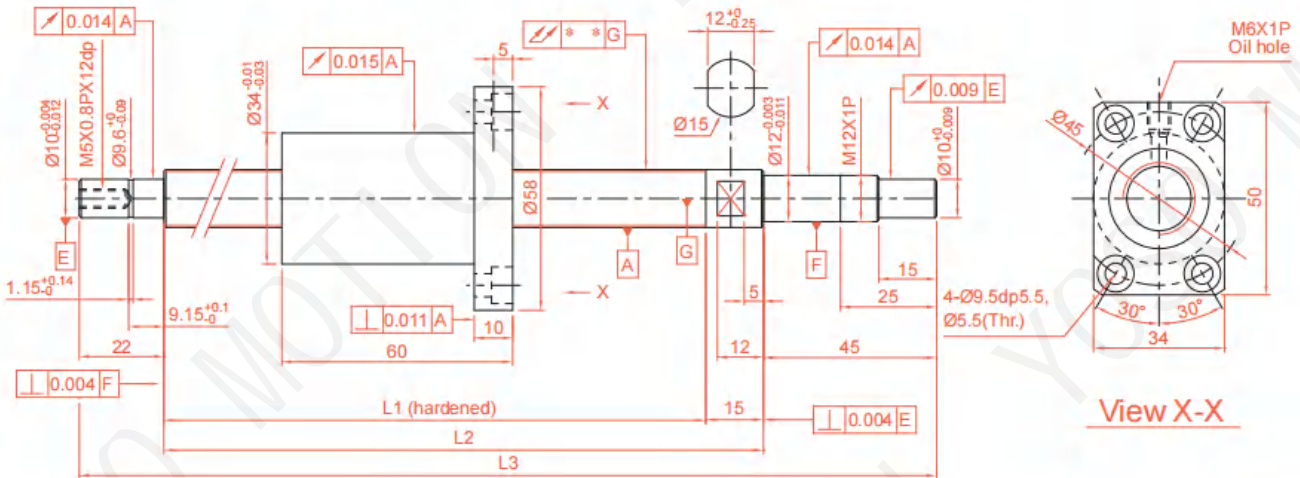

BCD	15.5
Ball Dia (mm)	3.175
Lead (mm)	20
No.of Turns	1.8x1
Lead Angle	22.33°
Threading Direction	R
Spring Force(kg)	0.1~0.3
Preload (kgf)	38
DynamicLoad Rating Ca (kgf)	580
Static Load Rating Coa(kgf)	875
Accuracy Grade	0.018

Unit : mm

Travel Length (mm)	Model No.	Shaft Length (mm)			Slant of Axle Center
		L1	L2	L3	\angle
100	XSVR01520A1DGC5-271-P1	189	204	271	0.025
150	XSVR01520A1DGC5-321-P1	239	254	321	0.035
200	XSVR01520A1DGC5-371-P1	289	304	371	0.035
250	XSVR01520A1DGC5-421-P1	339	354	421	0.040
300	XSVR01520A1DGC5-471-P1	389	404	471	0.040
350	XSVR01520A1DGC5-521-P1	439	454	521	0.050
400	XSVR01520A1DGC5-571-P1	489	504	571	0.050
450	XSVR01520A1DGC5-621-P1	539	554	621	0.050
500	XSVR01520A1DGC5-671-P1	589	604	671	0.065
550	XSVR01520A1DGC5-721-P1	639	654	721	0.065
600	XSVR01520A1DGC5-771-P1	689	704	771	0.065
700	XSVR01520A1DGC5-871-P1	789	804	871	0.085
800	XSVR01520A1DGC5-971-P1	889	904	971	0.085

YS-XSVR02010-00 Series Specifications (Finish Shaft Ends)

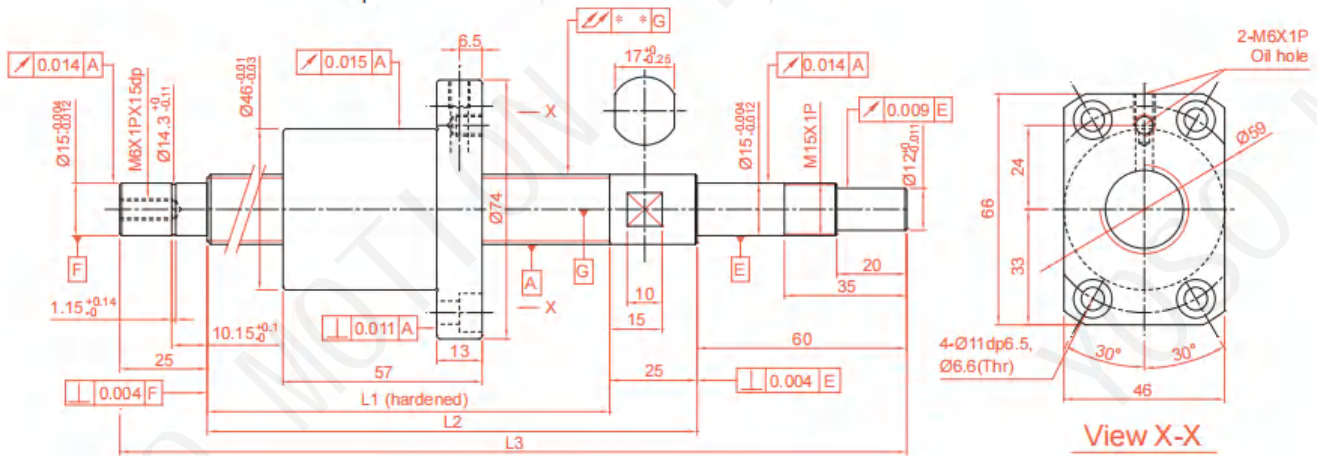

BCD	21.35
Ball Dia(mm)	3.969
Lead (mm)	10
No.of Turns	2.7x1
Lead Angle	8.48°
Threading Direction	R
Spring Force (kg)	0.1~0.3
Preload (kgf)	43
Dynamic Load Rating Ca(kgf)	977
Static Load Rating Coa(kgf)	1732
Accuracy Grade	0.018

Unit : mm

Travel Length (mm)	Model No.	Shaft Length (mm)			Slant of Axle Center ↗
		L1	L2	L3	
200	XSVR02010B1DGC5-399-P1	289	314	399	0.035
300	XSVR02010B1DGC5-499-P1	389	414	499	0.040
400	XSVR02010B1DGC5-599-P1	489	514	599	0.050
500	XSVR02010B1DGC5-699-P1	589	614	699	0.065
600	XSVR02010B1DGC5-799-P1	689	714	799	0.065
700	XSVR02010B1DGC5-899-P1	789	814	899	0.085
800	XSVR02010B1DGC5-999-P1	889	914	999	0.085
900	XSVR02010B1DGC5-1099-P1	989	1014	1099	0.110
1000	XSVR02010B1DGC5-1199-P1	1089	1114	1199	0.110

YOSO MOTION BALL SCREW

YS-XSVR02020-00 Series Specifications (Finish Shaft Ends)

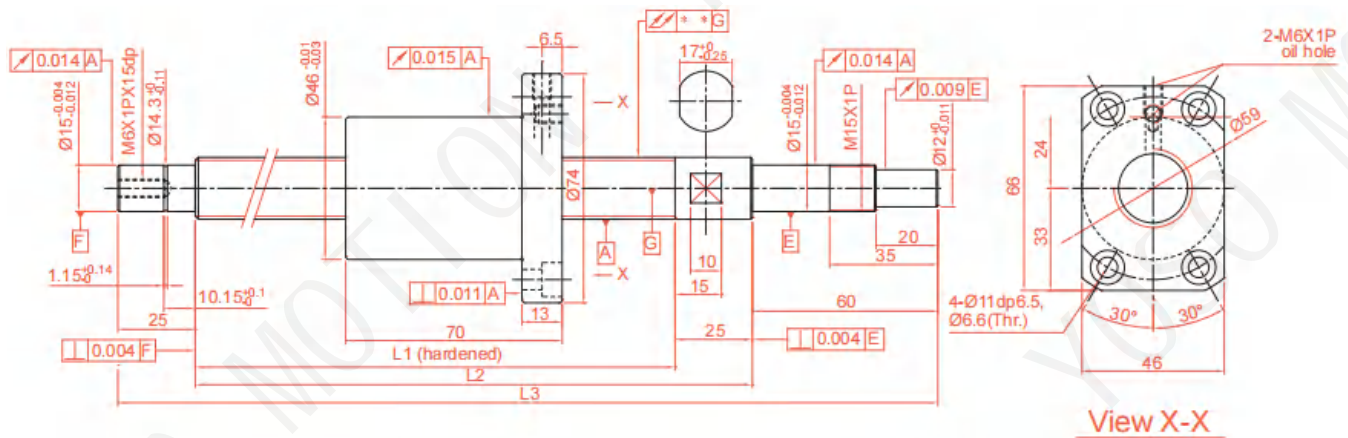

BCD	20.75
Ball Dia (mm)	3.175
Lead (mm)	20
No.of Turns	1.8x1
Lead Angle	17.05
Threading Direction	R
Spring Force (kg)	0.1~0.3
Preload (kgf)	31
Dynamic Load Rating Ca(kgf)	649
Static Load Rating Coa (kgf)	1134
Accuracy Grade	0.018

Unit : mm

Travel Length (mm)	Model No.	Shaft Length (mm)			Slant of Axle Center
		L1	L2	L3	\swarrow
200	XSVR02020A1DGC5-399-P1	289	314	399	0.035
300	XSVR02020A1DGC5-499-P1	389	414	499	0.040
400	XSVR02020A1DGC5-599-P1	489	514	599	0.050
500	XSVR02020A1DGC5-699-P1	589	614	699	0.065
600	XSVR02020A1DGC5-799-P1	689	714	799	0.065
700	XSVR02020A1DGC5-899-P1	789	814	899	0.085
800	XSVR02020A1DGC5-999-P1	889	914	999	0.085
900	XSVR02020A1DGC5-1099-P1	989	1014	1099	0.110
1000	XSVR02020A1DGC5-1199-P1	1089	1114	1199	0.110

2-3 Rolled Ball Screw

2-3-1 Rolled Screws

Rolled screws are made through thread roller. Generally rolled screw has a smoother operation while lowering friction and backlash. Therefore, it gradually replaced the traditional ACME screws and trapezoidal screws. Moreover, rolled screws can eliminate axial play by preloading nut with a cost effective pricing compare to ground screw.

2-3-2 The Features of YOSO MOTION Rolled Ball Screw

(1) Lead Accuracy Up to Grade C5

C7 and C10 Screws have been Standardized. C5 on request.

(2) Precision Ground Ball Nut

High Precision Ball Nut are interchangeable between ground and rolled screws.

(3) Available to ship separately

Ball screw and ball nuts can be shipped separated ensure shortest delivery time. The ball nuts are standardized with P0 preloaded, preload value can be adjusted through reballing.

2-3-3 Nominal Model Code of Rolled Ball Screws

Nominal Model Code of Shaft

YS-SC R 025 05 F C7 - 1000 + N3

①
②
③
④
⑤
⑥
⑦
⑧

①

Type of Screw Shaft

SC : standard

SS : For H, NH type nut

④

Lead

Unit : mm

⑦

Overall Length of Shaft

Unit : mm

②

Threading Direction

R : Right

B1 : Black Oxidation

⑤

Product Code

F : Rolled

⑧

Shaft Surface Treatment

: Standard

B1 : Black Oxidation

N1 : Hard Chrome Plating

P : Phosphating

N3 : Nickel Plating

N4 : Raydent

N5 : Chrome Plating

③

Nominal Diameter

Unit : mm

⑥

Accuracy Grade

C5, C7, C10

YOSO MOTION BALL SCREW

2-3 Rolled Ball Screw

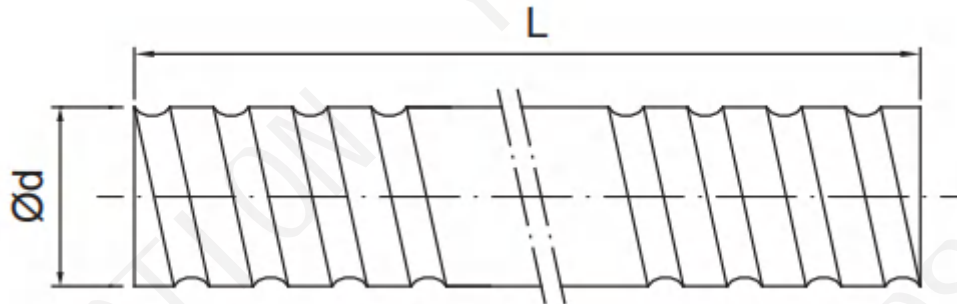

Fig 2.3.1 Screw Shaft Nominal Diameter

Table 2.3.1 Rolled Ball Screw Specifications $\varnothing 6\sim 32$

Unit : mm

Model No.			Accuracy Grade	Threading Direction R:Right L:Left	Number of Grooves	Standard Code of Shaft	Type of Nut	Overall Length of Shaft
d	l	Da						
6	1	0.8	C10,C7	R	1	SCR00601	K	1000
	1	0.8	C10,C7,C5	R	1	SCR00801	K	
8	2	1.2	C10,C7,C5	R	1	SCR00802	K	1000
	2.5	1.2	C10,C7,C5	R	1	SCR0082.5	K,BSH	
10	2	1.2	C10,C7,C5	R	1	SCR01002	K,BSH	3000
	4	2	C10,C7,C5	R	1	SCR01004	K,BSH	
12	2	1.2	C10,C7,C5	R	1	SCR01202	K	3000
	4	2.5	C10,C7,C5	R	1	SCR01204	U,BSH	
	5	2.5	C10,C7,C5	R	1	SCR01205-A	V,U,BSH,H,A	
	10	2.5	C10,C7,C5	R	2	SCR01210-B	V	
	20	2.5	C10,C7	R	4	SCR01220	Y	
14	2	1.2	C10,C7,C5	R	1	SCR01402	K	1800
	4	2.5	C10,C7	R	1	SCR01404	BSH	3000
16	4	2.381	C10,C7,C5	R	1	SCR01604(N)	V,I,U,BSH	3000
	5	3.175	C10,C7,C5	R/L	1	SCR01605	V,NI,NU,BSH	
	10	3.175	C10,C7,C5	R	2	SCR01610	V,NI,NU,BSH	
	16	2.778	C10,C7,C5	R	4	SCR01616	Y	
	32	2.778	C10,C7	R	8	SCR01632	Y	
20	4	2.381	C10,C7,C5	R	1	SCR02004(N)	V,I,U	3000
	5	3.175	C10,C7,C5	R/L	1	SCR02005	V,NI,NU,BSH,H,A	
	20	3.175	C10,C7,C5	R	4	SCR02020	V,Y,H,A	
	40	3.175	C10,C7	R	8	SCR02040	Y	
25	4	2.381	C10,C7	R	1	SCR02504(N)	I,U	6000
	5	3.175	C10,C7,C5	R/L	1	SCR02505	V,NI,NU,BSH,H,A	
	10	4.762	C10,C7,C5	R	1	SCR02510-A	NI,NU,BSH	
	10	6.35	C10,C7,C5	R	1	SCR02510-B	V	
	25	3.969	C10,C7,C5	R	4	SCR02525	Y	
	50	3.969	C10,C7	R	8	SCR02550	Y	
32	4	2.381	C10,C7,C5	R	1	SCR03204(N)	V,I,U	6000
	5	3.175	C10,C7,C5	R/L	1	SCR03205	V,NI,NU,M,H,A	
	10	6.35	C10,C7,C5	R/L	1	SCR03210	V,NI,NU	
	32	4.762	C10,C7	R	4	SCR03232	Y	
	64	4.762	C10,C7	R	8	SCR03264	Y	

Table2.3.2 Standard Specifications Ø40~80

Unit : mm

Model No.			Accuracy Grade	Threading Direction	Number of Grooves	Standard Code of Shaft	Type of Nut	Overall Length of Shaft
d	l	Da		R:Right L:Left				
40	5	3.175	C10,C7,C5	R/L	1	SCR04005	V,NI,NU,H,A	6000
	10	6.35	C10,C7	R/L	1	SCR04010	V,NI,NU	
	20	6.35	C10,C7	R	2	SCR04020	V	
	40	6.35	C10,C7	R	4	SCR04040	Y	
	80	6.35	C10,C7	R	8	SCR04080	Y	
50 [•]	5	3.175	C10,C7,C5	R	1	SCR05005	V,H,A	6000
	10	6.35	C10,C7,C5	R/L	1	SCR05010	V,NI,NU	
	20	9.525	C10,C7	R	1	SCR05020	V	
	50	7.938	C10,C7	R	4	SCR05050	Y	
	100	7.938	C10,C7	R	8	SCR050100	Y	
63 [•]	10	6.35	C10,C7,C5	R	1	SCR06310	V,NI,NU	7000
	20	9.525	C10,C7	R	1	SCR06320	V,NU	
80 [•]	10	6.35	C10,C7,C5	R	1	SCR08010	V,NI,NU	7000
	20	9.525	C10,C7	R	1	SCR08020	V,U	

Table2.3.3 H, A-Type Specifications Ø16~50

Model No.			Accuracy Grade	Threading Direction	Number of Grooves	Type-H Code of Shaft	Type of Nut	Overall Length of Shaft
d	l	Da		R:Right L:Left				
12	10	2.5	C10,C7,C5	R	2	SSR01210	H,A	3000
16	5	2.778	C10,C7,C5	R	1	SSR01605	H,A	3000
	10	2.778	C10,C7,C5	R	2	SSR01610	H,A	
	16	2.778	C10,C7,C5	R	4	SSR01616	H,A	
	20	2.778	C10,C7,C5	R	4	SSR01620	H,A	
20	10	3.175	C10,C7,C5	R	2	SSR02010	H,A	3000
25	10	3.175	C10,C7,C5	R	2	SSR02510	H,A	6000
	25	3.175	C10,C7	R	4	SSR02525	H,A	
32	10	3.969	C10,C7,C5	R	1	SSR03210	H,A	6000
	20	3.969	C10,C7	R	2	SSR03220	H,A	
	32	3.969	C10,C7	R	4	SSR03232	H,A	
40	10	6.35	C10,C7	R	1	SSR04010	H,A	6000
	20	6.35	C10,C7,C5	R	2	SSR04020	H,A	
	40	6.35	C10,C7	R	4	SSR04040	H,A	
50 [•]	10	6.35	C10,C7	R	1	SSR05010	H,A	6000
	20	6.35	C10,C7	R	2	SSR05020	H,A	
	50	6.35	C10,C7	R	4	SSR05050	H,A	

※The information is for standard production, if required accuracy grade C5 or other needs, please contact Y O S O M O T I O N .

※Please contact YOSO MOTION if the marked types (●) are required.

YOSO MOTION BALL SCREW

2-4 Rolled Ball Screw Series

Nominal Model Code of Nut

YS-G SFU R 025 05 T4 D + N3

① ② ③ ④ ⑤ ⑥ ⑦ ⑧

①

Product Code

②

Nominal Model

S	S : Single nut
	D : Double nut
	O : OFF set double nut
F	F : With flange
	C : Without flange
U	NI : NI type nut
	NU : NU type nut
	H : H type nut
	A : A type nut
	NH : NH nut (A solution for slide table)
	Y : Y type nut
	V : V type nut
	U : DIN nut
	M : M type nut
K : K type nut	

③

Threading Direction

R : Right
L : Left

④

Nominal Diameter

Unit : mm

⑤

Lead

Unit : mm

⑥

Number of Turns (Turn•Row)

Turn : T : 1
A : 1.5 (or 1.7/1.8)
B : 2.5/2.8
C : 3.5
D : 4.8
ex : (2.5 x 2 = B2)

⑦

Flange Type

N : Not cutting
S : Single cutting
D : Double cutting

⑧

Shaft Surface Treatment

: Standard
B1 : Black Oxidation
N1 : Hard Chrome Plating
P : Phosphating
N3 : Nickel Plating
N4 : Raydent
N5 : Chrome Plating

■ 2-3-4 Preload of Rolled Ball Screw

The standard preloading for Rolled Ball Screw is P0. If P1 preloading is required, please contact YOSO MOTION

Table2.3.4 Rolled screw accuracy

Unit : mm

Accuracy Grade	C5(DIN)	C7	C10
e300	23	50	210

2-4-1 YOSO MOTION Nut of Rolled Ball Screw Type

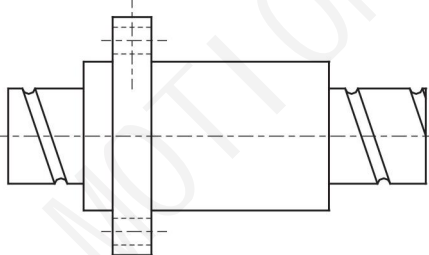
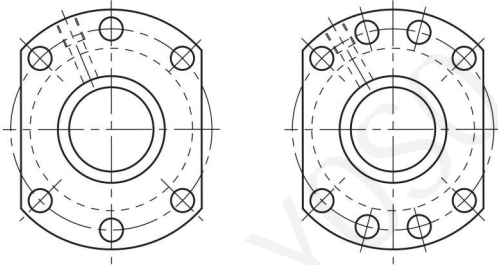
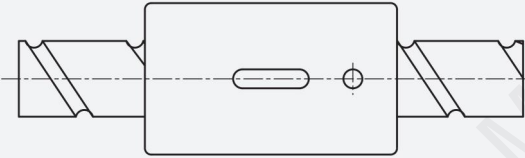
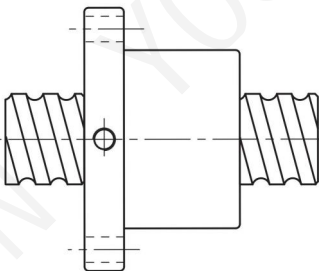
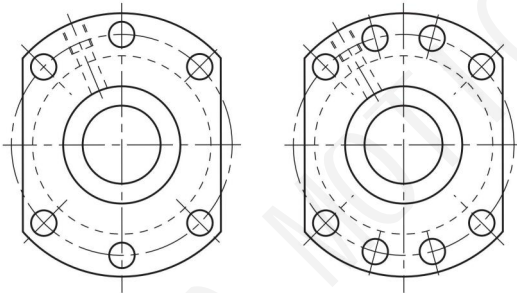
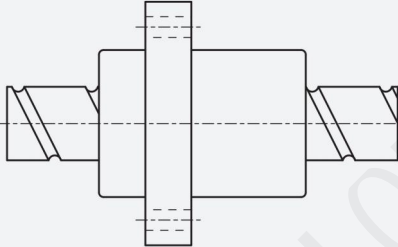
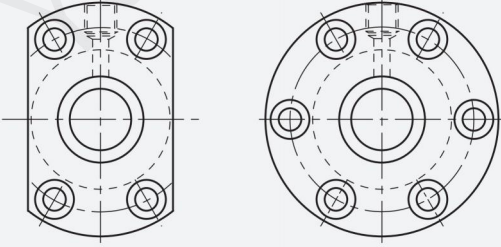
	Nut Type	Flange Type
<p>NH/H/A (A solution for slide table/High speed/Strong dust-proof type)</p>	<p>YS-SFNH/SFH/SFA(DIN)</p>  <p>C70, 71</p>	 <p>$d \leq 32$ $d \geq 40$</p>
<p>CNH (A solution for slide table)</p>	<p>YS-SCNH</p>  <p>C72</p>	<p>No-Flange</p>
<p>NU (Strong dust-proof type)</p>	<p>YS-SFNU/ SFU(DIN)</p>  <p>C73</p>	 <p>$d \leq 32$ $d \geq 40$</p>
<p>NI (Strong dust-proof type)</p>	<p>YS-SFNI/SFI</p>  <p>C74</p>	

YOSO MOTION BALL SCREW

2-4 Rolled Ball Screw Series

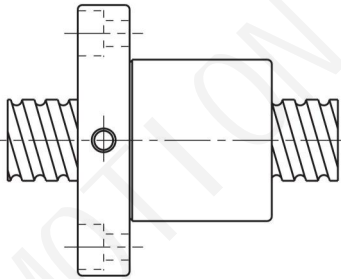
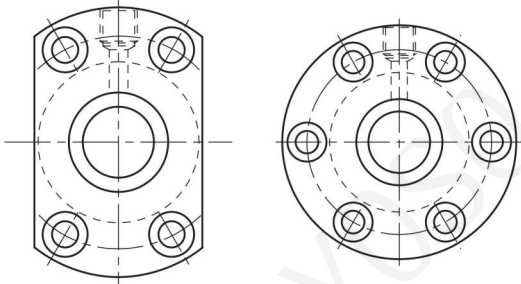
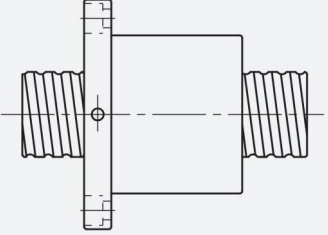
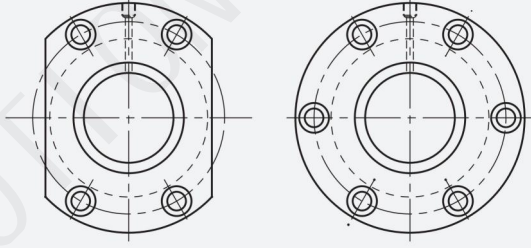
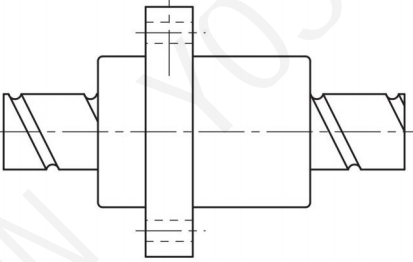
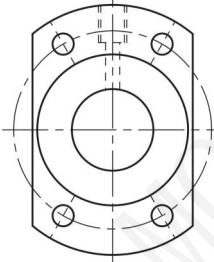
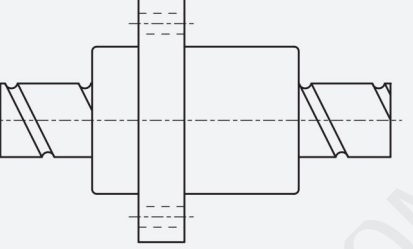
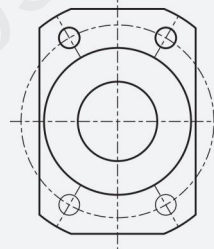
	Nut Type	Flange Type
Σ (Design for Milling)	YS-SFM  C74	
$\frac{H}{C}$ (High Load External Circulation type)	YS-SFV  C75	
\succ (High DM-N Rating)	YS-SFY  C76	
$\frac{X}{S}$ (Miniature type)	YS-XSY  C77	

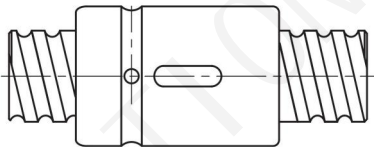
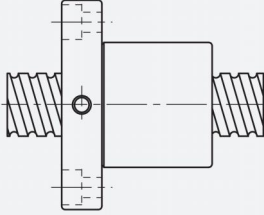
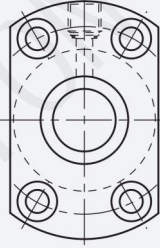
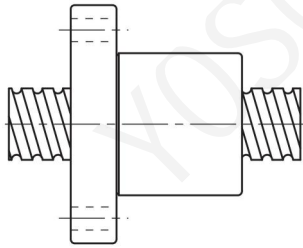
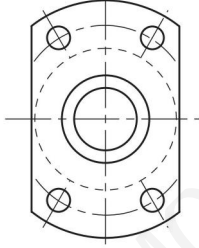
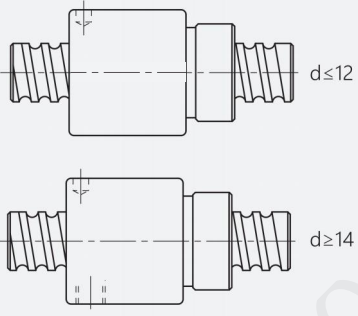
	Nut Type	Flange Type
CNI/I (Standard)	<p>YS-SCNI/SCI</p>  <p>C78</p>	No-Flange
K (Miniature type)	<p>YS-SFK</p>  <p>C79</p>	 <p>(SFK 01004) (SFK 02002) (SFK 02502)</p>
	<p>YS-SFK</p>  <p>C79</p>	
BSH	<p>YS-BSH</p>  <p>$d \leq 12$ $d \geq 14$</p> <p>C80</p>	No-Flange

※The information is for specifications, if customized products are needed please contact YOSOMOTION.

YOSO MOTION BALL SCREW

2-4 Rolled Ball Screw Series

SFS Series Specifications

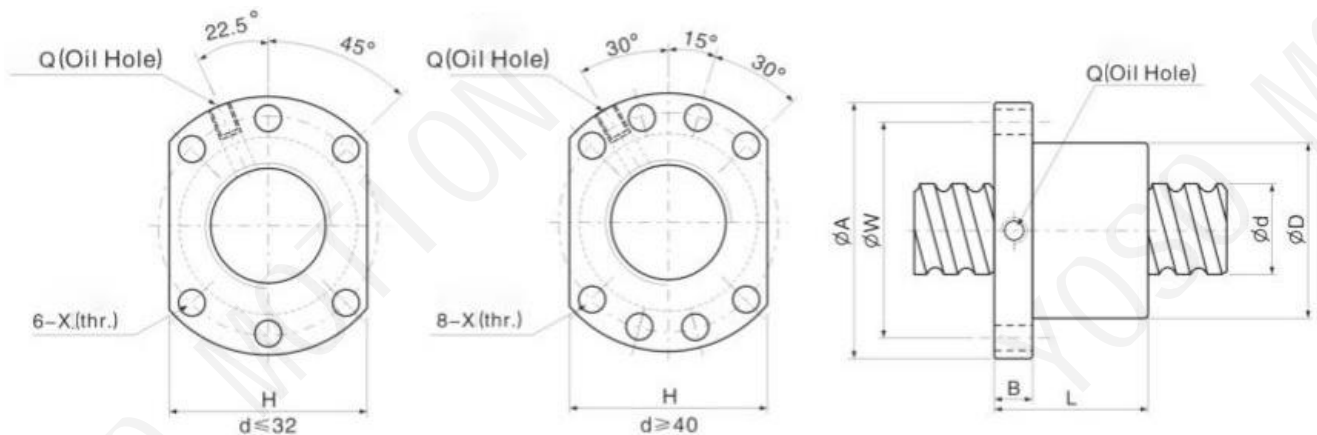

Unit : mm

Model No	d	l	Da	Dimension									Load Rating		K kgf/μm
				D	A	B	L	W	H	X	Q	n	Ca(kgf)	Coa(kgf)	
YS-SFS1205-2.8★	12	5	2.5	24	40	10	31	32	30	4.5	M6	2.8×1	477	866	14.25
YS-SFS1210-2.8★		10	2.5	24	40	10	48.5	32	30	4.5	M6	2.8×1	470	842	14.25
YS-SFS1605-3.8★	15	5	2.778	28	48	10	38	38	40	5.5	M6	3.8×1	785	1588	22.5
YS-SFS1610-2.8★		10	2.778	28	48	10	47	38	40	5.5	M6	2.8×1	596	1170	17.25
YS-SFS1616-1.8★		16	2.778	28	48	10	45	38	40	5.5	M6	1.8×1	417	800	10.5
YS-SFS1616-2.8★		16	2.778	28	48	10	61	38	40	5.5	M6	2.8×1	609	1245	16.5
YS-SFS1620-1.8★	20	2.778	28	48	10	57	38	40	5.5	M6	1.8×1	410	801	10.5	
YS-SFS2005-3.8★	20	5	3.175	36	58	10	40	47	44	6.6	M6	3.8×1	1093	2510	27.75
YS-SFS2010-3.8★		10	3.175	36	58	10	60	47	44	6.6	M6	3.8×1	1088	2512	30
YS-SFS2020-1.8★		20	3.175	36	58	10	57	47	44	6.6	M6	1.8×1	575	1231	14.25
YS-SFS2020-2.8★		20	3.175	36	58	10	77	47	44	6.6	M6	2.8×1	841	1951	21.75
YS-SFS2505-3.8★	25	5	3.175	40	62	10	40	51	48	6.6	M6	3.8×1	1153	2935	32.25
YS-SFS2510-3.8★		10	3.175	40	62	12	62	51	48	6.6	M6	3.8×1	1150	2938	33.75
YS-SFS2525-1.8★		25	3.175	40	62	12	70	51	48	6.6	M6	1.8×1	627	1523	16.5
YS-SFS2525-2.8★		25	3.175	40	62	12	95	51	48	6.6	M6	2.8×1	917	2369	25.5
YS-SFS3205-3.8	32	5	3.175	50	80	12	42	65	62	9	M6	3.8×1	1370	4178	38.25
YS-SFS3210-3.8		10	3.969	50	80	13	62	65	62	9	M6	3.8×1	1818	4967	41.25
YS-SFS3220-2.8		20	3.969	50	80	12	80	65	62	9	M6	2.8×1	1386	3664	32.25
YS-SFS3232-1.8		32	3.969	50	80	13	84	65	62	9	M6	1.8×1	933	2361	20.25
YS-SFS3232-2.8	32	3.969	50	80	13	116	65	62	9	M6	2.8×1	1364	3673	31.5	
YS-SFS4005-3.8	40	5	3.175	63	93	15	45	78	70	9	M8	3.8×1	1510	5291	45
YS-SFS4010-3.8		10	6.35	63	93	14	63	78	70	9	M8	3.8×1	3672	9311	50.25
YS-SFS4020-2.8		20	6.35	63	93	14	82	78	70	9	M8	2.8×1	2808	6868	40.5
YS-SFS4040-1.8		40	6.35	63	93	15	105	78	70	9	M8	1.8×1	1881	4433	25.5
YS-SFS4040-2.8	40	6.35	63	93	15	145	78	70	9	M8	2.8×1	2751	6895	39	
YS-SFS5005-3.8	50	5	3.175	75	110	15	45	93	85	11	M8	3.8×1	1656	6685	51
YS-SFS5010-3.8		10	6.35	75	110	18	68	93	85	11	M8	3.8×1	4176	12265	59.25
YS-SFS5020-3.8		20	6.35	75	110	18	108	93	85	11	M8	3.8×1	4162	12272	65.25
YS-SFS5050-1.8		50	6.35	75	110	18	125	93	85	11	M8	1.8×1	2139	5832	31.5
YS-SFS5050-2.8	50	6.35	75	110	18	175	93	85	11	M8	2.8×1	3127	9073	48.75	

※ ★ Actuator type available.

※ Please contact YOSO MOTION if the marked types (●) are required.

SFNH/SFH (DIN 69051 FORM B) Series Specifications

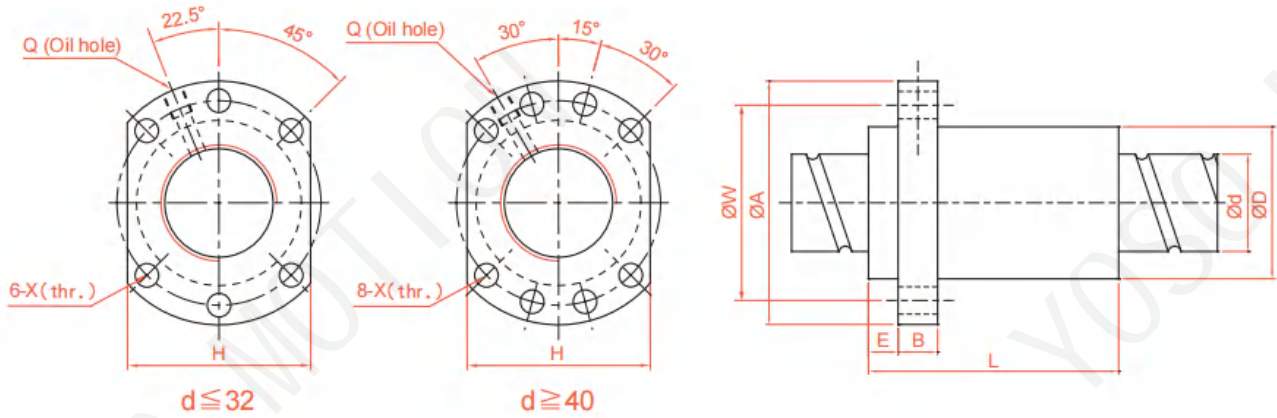

Unit : mm

Model No.	d	l	Da	Dimension										Load Rating		K
				D	A	E	B	L	W	H	X	Q	n	Ca(kgf)	Coa(kgf)	kgf/μm
YS-SFH01205-2.8★	12	5	2.5	24	40	5	10	30	32	30	4.5		2.8x1	661	1316	19
YS-SFH01210-2.8★		10	2.5	24	40	5	10	45	32	30	4.5		2.8x1	642	1287	19
YS-SFH01605-3.8★	15	5	2.778	28	48	5	10	37	38	40	5.5	M6	3.8x1	1112	2507	30
YS-SFH01610-2.8★		10	2.778	28	48	5	10	45	38	40	5.5	M6	2.8x1	839	1821	23
YS-SFH01616-1.8★		16	2.778	28	48	5		45	38	40	5.5	M6	1.8x1	552	1137	14
YS-SFH01616-2.8★		16	2.778	28	48	5	10	61	38	40	5.5	M6	2.8x1	808	1769	22
YS-SFH01620-1.8★		20	2.778	28	48	7	10	58	38	40	5.5	M6	1.8x1	554	1170	14
YS-SFH02005-3.8★	20	5	3.175	36	58	7	10	37	47	44	6.6	M6	3.8x1	1484	3681	37
YS-SFH02010-3.8★		10	3.175	36	58	7	10	55	47	44	6.6	M6	3.8x1	1516	3833	40
YS-SFH02020-1.8★		20	3.175	36	58	7	10	54	47	44	6.6	M6	1.8x1	764	1758	19
YS-SFH02020-2.8★		20	3.175	36	58	7	10	74	47	44	6.6	M6	2.8x1	1118	2734	29
YS-SFH02505-3.8★	25	5	3.175	40	62	7	10	37	51	48	6.6	M6	3.8x1	1650	4658	43
YS-SFH02510-3.8★		10	3.175	40	62	7	12	55	51	48	6.6	M6	3.8x1	1638	4633	45
YS-SFH02525-1.8★		25	3.175	40	62	7	12	64	51	48	6.6	M6	1.8x1	843	2199	22
YS-SFH02525-2.8★		25	3.175	40	62	7	12	89	51	48	6.6	M6	2.8x1	1232	3421	34
YS-SFH03205-3.8	32		3.175	50	80	9	12	37	65	62	9	M6	3.8x1	1839	6026	51
YS-SFH03210-3.8	31	10	3.969	50	80	9	1	57	65	62	9	M6	3.8x1	2460	7255	55
YS-SFH03220-2.8		20	3.969	0	80	9	12	76	65	62	9	M6	2.8x1	1907	5482	43
YS-SFH03232-1.8		32	3.969	50	80	9	12	80	65	62	9	M6	1.8x1	1257	3426	27
YS-SFH03232-2.8		32	3.969	50	80	9	12	112	65	62	9	M6	2.8x1	1838	5329	42
YS-SFH04005-3.8	40	5	3.175	63	93	9	15	42	78	70	9	M8	3.8x1	2018	7589	60
YS-SFH04010-3.8	38	10	6.35	63	93	9	14	60	78	70	9	M8	3.8x1	5035	13943	67
YS-SFH04020-2.8		20	6.35	63	93	9	14	80	78	70	9	M8	2.8x1	3959	10715	54
YS-SFH04040-1.8		40	6.35	63	93	9	14	98	78	70	9	M8	1.8x1	2585	6648	34
YS-SFH04040-2.8		40	6.35	63	93	9	14	138	78	70	9	M8	2.8x1	3780	10341	52
YS-SFH05005-3.8●	50	5	3.175	75	110	10.5	15	42	93	85	11	M8	3.8x1	2207	9542	68
YS-SFH05010-3.8●	48	10	6.35	75	110	10.5	18	60	93	85	11	M8	3.8x1	5638	17852	79
YS-SFH05020-3.8●		20	6.35	75	110	10.5	18	100	93	85	11	M8	3.8x1	5749	18485	87
YS-SFH05050-1.8●		50	6.35	75	110	10.5	18	120	93	85	11	M8	1.8x1	2946	8749	42
YS-SFH05050-2.8●		50	6.35	75	110	10.5	18	170	93	85	11	M8	2.8x1	4308	13610	65

※ ★ Actuator type available.

※ Please contact YOSO MOTION if the marked types (●) are required.

YOSO MOTION BALL SCREW

2-4 Rolled Ball Screw Series

SFA Series Specifications

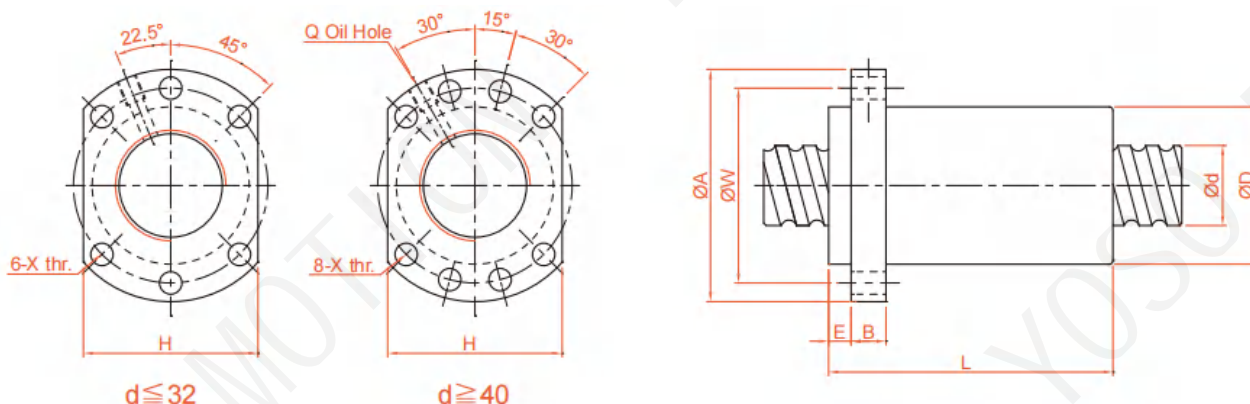

Unit : mm

Model No	d	l	Da	Dimension										Load Rating		K kgf/μm	
				D	A	E	B	L	W	H	X	Q	n	Ca(kgf)	Coa(kgf)		
YS-SFA1205-2.8★	12	5	2.5	24	40	5	10	30	32	30	4.5		2.8×1	661	1316	19	
YS-SFA1210-2.8★		10	2.5	24	40	5	10	42	32	30	4.5		2.8×1	642	1287	19	
YS-SFA1605-3.8★	15	5	2.778	28	48	5	10	31	38	40	5.5	M6	3.8×1	1112	2507	30	
YS-SFA1610-2.8★		10	2.778	28	48	5	10	42	38	40	5.5	M6	2.8×1	839	1821	23	
YS-SFA1616-1.8★		16	2.778	28	48	5	10	43	38	40	5.5	M6	1.8×1	552	1137	14	
YS-SFA1616-2.8★		16	2.778	28	48	5	10	59	38	40	5.5	M6	2.8×1	808	1769	22	
YS-SFA1620-1.8★	20	20	2.778	28	48	5	10	50	38	40	5.5	M6	1.8×1	554	1170	14	
YS-SFA1630-1.8★		30	2.778	28	48	7	10	70	38	40	5.5	M6	1.8×1	534	1195	14	
YS-SFA2005-3.8★		5	3.175	36	58	7	10	33	47	44	6.6	M6	3.8×1	1484	3681	37	
YS-SFA2010-3.8★		10	3.175	36	58	7	10	52	47	44	6.6	M6	3.8×1	1516	3833	40	
YS-SFA2020-1.8★	25	20	3.175	36	58	7	10	52	47	44	6.6	M6	1.8×1	764	1758	19	
YS-SFA2020-2.8★		20	3.175	36	58	7	10	72	47	44	6.6	M6	2.8×1	1118	2734	29	
YS-SFA2505-3.8★		5	3.175	40	62	7	10	33	51	48	6.6	M6	3.8×1	1650	4658	43	
YS-SFA2510-3.8★		10	3.175	40	62	7	12	52	51	48	6.6	M6	3.8×1	1638	4633	45	
YS-SFA2525-1.8★	32	25	3.175	40	62	7	12	60	51	48	6.6	M6	1.8×1	843	2199	22	
YS-SFA2525-2.8★		25	3.175	40	62	7	12	85	51	48	6.6	M6	2.8×1	1232	3421	34	
YS-SFA3205-3.8	31	5	3.175	50	80	9	12	35	65	62	9	M6	3.8×1	1839	6026	51	
YS-SFA3210-3.8		10	3.969	50	80	9	12	53	65	62	9	M6	3.8×1	2460	7255	55	
YS-SFA3220-2.8		20	3.969	50	80	9	12	72	65	62	9	M6	2.8×1	1907	5482	43	
YS-SFA3232-1.8		32	3.969	50	80	9	12	78	65	62	9	M6	1.8×1	1257	3426	27	
YS-SFA3232-2.8		32	3.969	50	80	9	12	110	65	62	9	M6	2.8×1	1838	5329	42	
YS-SFA4005-3.8	38	40	5	3.175	63	93	9	14	39	78	70	9	M8	3.8×1	2018	7589	60
YS-SFA4010-3.8		10	6.35	63	93	9	14	57	78	70	9	M8	3.8×1	5035	13943	67	
YS-SFA4020-2.8		20	6.35	63	93	9	14	78	78	70	9	M8	2.8×1	3959	10715	54	
YS-SFA4040-1.8		40	6.35	63	93	9	14	96	78	70	9	M8	1.8×1	2585	6648	34	
YS-SFA4040-2.8		40	6.35	63	93	9	14	136	78	70	9	M8	2.8×1	3780	10341	52	
YS-SFA5005-3.8●	48	50	5	3.175	75	110	10.5	15	42	93	85	11	M8	3.8×1	2207	9542	68
YS-SFA5010-3.8●		10	6.35	75	110	10.5	18	57	93	85	11	M8	3.8×1	5638	17852	79	
YS-SFA5020-3.8●		20	6.35	75	110	10.5	18	98	93	85	11	M8	3.8×1	5749	18485	87	
YS-SFA5050-1.8●		50	6.35	75	110	10.5	18	117	93	85	11	M8	1.8×1	2946	8749	42	
YS-SFA5050-2.8●		50	6.35	75	110	10.5	18	167	93	85	11	M8	2.8×1	4308	13610	65	

※ ★ Actuator type available.

※ Please contact YOSO MOTION if the marked types (●) are required.

YS-SCNH Series Specifications

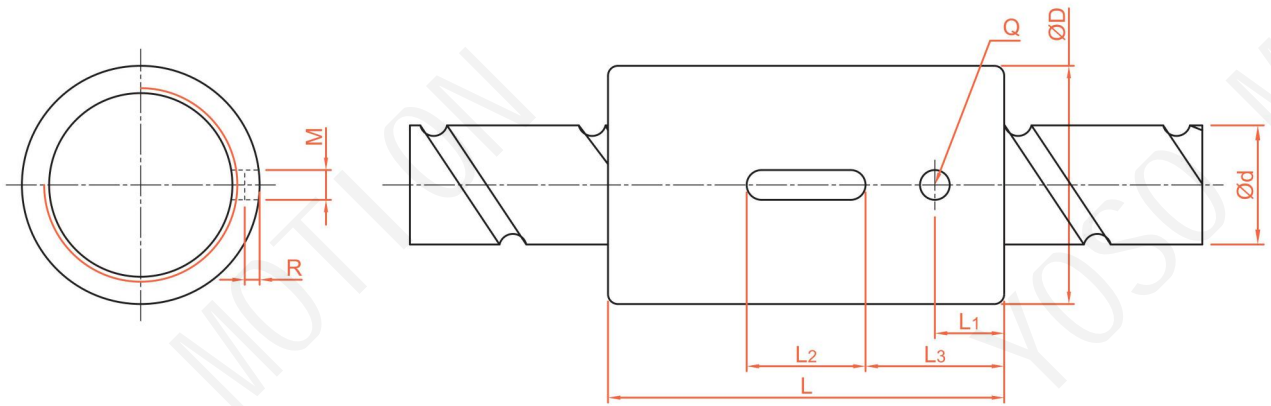

Unit : mm

Model No.	d	l	Da	Dimension									Load Rating		K kgf/μm
				D	L	L1	L2	L3	M	R	Q	n	Ca(kgf)	Coa (kgf)	
YS-SCNH01205-4.8	12	5	2.5	24	40	7	12	14	3	1.5	3	4.8x1	1051	2255	34
YS-SCNH01210-2.8		10	2.5	24	45	8	15	15	3	1.5	3	2.8x1	642	1287	19
YS-XCNH01210-1.8		10	2.5	24	40	10.5	12	14	3	1.5	3	1.8x1	439	827	33
YS-SCNH01605-5.8	15	5	2.778	28	45	7	20	12.5	5	3	3	5.8x1	1599	3827	49
YS-SCNH01610-2.8		10	2.778	28	45	7	20	12.5	5	3	3	2.8x1	839	1821	23
YS-SCNH01616-1.8		16	2.778	28	A	7	20	12.5	5	3	3	1.8x1	552	1137	18
YS-SCNH01620-1.8		20	2.778	28	58	10	20	19	5	3	3	1.8x1	554	1170	14
YS-SCNH02005-5.8	20	5	3.175	36	47	8	20	13.5	5	3	3	5.8x1	2134	5619	60
YS-SCNH02010-3.8		10	3.175	36	55	8	20	17.5	5	3	3	3.8x1	1516	3833	40
YS-SCNH02020-1.8		20	3.175	36	55	8	20	17.5	5	3	3	1.8x1	764	1758	19

YOSO MOTION BALL SCREW

2-4 Rolled Ball Screw Series

YS-SFNU/SFU (DIN 69051 FORM B) Series Specifications

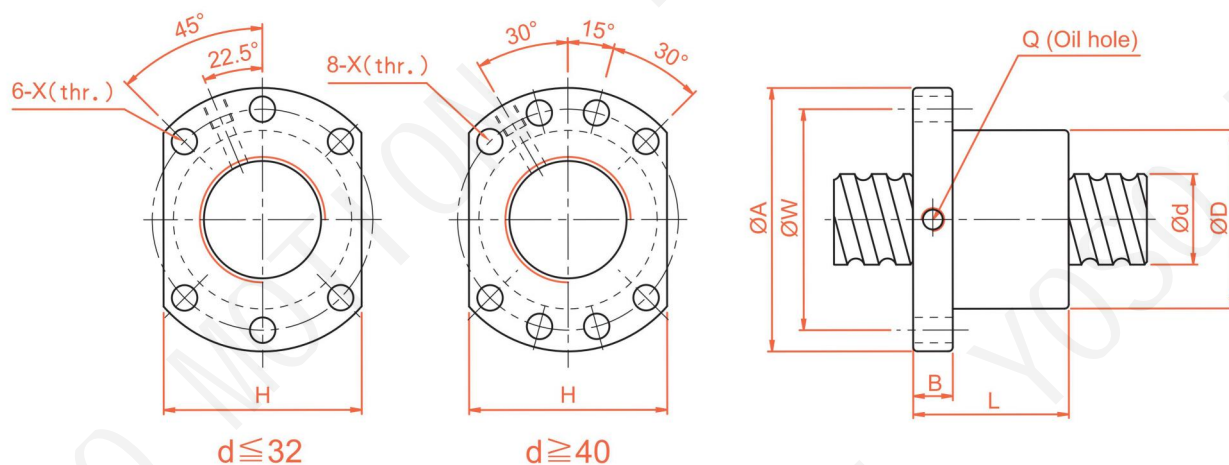

Unit : mm

Model No.	d	l	Da	Dimension									Load Rating		K kgf/ µm
				D	A	B	L	W	H	X	Q	n	Ca (kgf)	Coa (kgf)	
YS-SFNU01605-4★	16	5	3.175	28	48	10	45	38	40	5.5	M6	1x4	1380	3052	32
YS-SFNU01610-3		10	3.175	28	48	10	57	38	40	5.5	M6	1x3	1103	2401	26
YS-SFNU02005-4★	20	5	3.175	36	58	10	51	47	44	6.6	M6	1x4	1551	3875	39
YS-SFNU02505-4★	25	5	3.175	40	62	10	51	51	48	6.6	M6	1x4	1724	4904	45
YS-SFNU02510-4		10	4.762	40	62	12	80	51	48	6.6	M6	1x4	2954	7295	50
YS-SFNU03205-4★	32	5	3.175	50	80	12	52	65	62	9	M6	1x4	1922	6343	54
YS-SFNU03210-4★		10	6.35	50	80	12	85	65	62	9	M6	1x4	4805	12208	61
YS-SFNU04005-4★	40	5	3.175	63	93	14	55	78	70	9	M8	1x4	2110	7988	63
YS-SFNU04010-4★		10	6.35	63	93	14	88	78	70	9	M8	1x4	5399	15500	73
YS-SFNU05010-4★●	50	10	6.35	75	110	16	88	93	85	11	M8	1x4	6004	19614	85
YS-SFNU06310-4●	63	10	6.35	90	125	18	93	108	95	11	M8	1x4	6719	25358	99
YS-SFNU08010-4●	80	10	6.35	105	145	20	93	125	110	13.5	M8	1x4	7346	31953	109
YS-SFU01204-4	12	4	2.5	24	40	10	40	32	30	4.5		1x4	902	1884	26
YS-SFU01604-4	16	4	2.381	28	48	10	40	38	40	5.5	M6	1x4	973	2406	32
YS-SFU02004-4	20	4	2.381	36	58	10	42	47	44	6.6	M6	1x4	1066	2987	38
YS-SFU02504-4	25	4	2.381	40	62	10	42	51	48	6.6	M6	1x4	1180	3795	43
YS-SFU02506-4		6	3.969	40	62	10	54	51	48	6.6	M6	1x4	2318	6057	47
YS-SFU02508-4		8	4.762	40	62	10	63	51	48	6.6	M6	1x4	2963	7313	49
YS-SFU03204-4	32	4	2.381	50	80	12	44	65	62	9	M6	1x4	1296	4838	51
YS-SFU03206-4		6	3.969	50	80	12	57	65	62	9	M6	1x4	2632	7979	57
YS-SFU03208-4		8	4.762	50	80	12	65	65	62	9	M6	1x4	3387	9622	60
YS-SFU04006-4	40	6	3.969	63	93	14	60	78	70	9	M6	1x4	2873	9913	66
YS-SFU04008-4		8	4.762	63	93	14	67	78	70	9	M6	1x4	3712	11947	70
YS-SFU05020-4●	50	20	7.144	75	110	16	138	93	85	11	M8	1x4	7142	22588	94
YS-SFU06320-4●	63	20	9.525	95	135	20	149	115	100	13.5	M8	1x4	11444	36653	112
YS-SFU08020-4●	80	20	9.525	125	165	25	154	145	130	13.5	M8	1x4	12911	47747	138
YS-SFU10020-4●	100	20	9.525	150	202	30	180	170	155	17.5	M8	1x4	14303	60698	162

※ Left helix available

※ Please contact YOSO MOTION if the marked types (●) are required.

YS-SFNI/SFI Series Specifications

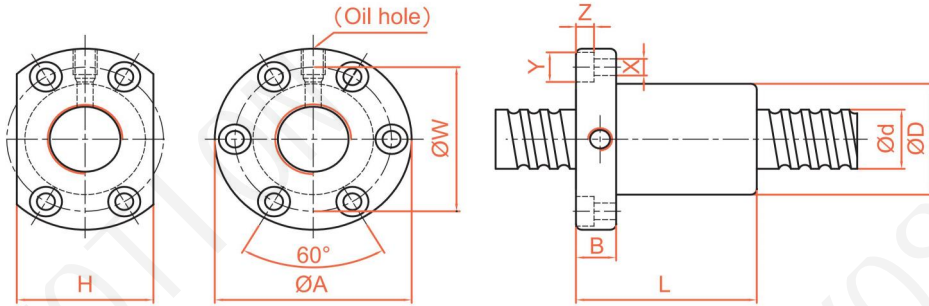

Unit : mm

Model No.	d	l	Da	Dimension											Load Rating		K kgf/μm
				D	A	B	L	W	H	X	Y	Z	Q	n	Ca (kgf)	Coa (kgf)	
YS-SFNI01605-4★	16	5	3.175	30	49	10	45	39	34	4.5	8	4.5	M6	1x4	1380	3052	33
YS-SFNI01610-3		10	3.175	34	58	10	57	AD	34	5.5	9.5	5.5	M6	1x3	1103	2401	27
YS-SFNI02005-4★	20	5	3.175	34	57	11	51	45	40	5.5	9.5	5.5	M6	1x4	1551	3875	39
YS-SFNI02505-4★	25	5	3.175	40	63	11	51	51	46	5.5	9.5	5.5	M8	1x4	1724	4904	45
YS-SFNI02510-4		10	4.762	46	72	12	80	58	52	6.5	11	6.5	M6	1x4	2954	7295	51
YS-SFNI03205-4★	32	5	3.175	46	72	12	52	58	52	6.5	11	6.5	M8	1x4	1922	6343	52
YS-SFNI03210-4★		10	6.35	54	88	15	85	70	62	9	14	8.5	M8	1x4	4805	12208	62
YS-SFNI04005-4★	40	5	3.175	56	90	15	55	72	64	9	14	8.5	M8	1x4	2110	7988	59
YS-SFNI04010-4★		10	6.35	62	104	18	88	82	70	11	17.5	11	M8	1x4	5399	15500	72
YS-SFNI05010-4★	50	10	6.35	72	114	18	88	92	82	11	17.5	11	M8	1x4	6004	19614	83
YS-SFNI06310-4	63	10	6.35	85	131	22	93	107	95	14	20	13	M8	1x4	6719	25358	95
YS-SFNI08010-4	80	10	6.35	105	150	22	93	127	115	14	20	13	M8	1x4	7346	31953	109
YS-SFI01604-4	16	4	2.381	30	49	10	45	39	34	4.5	8	4.5	M6	1x4	973	2406	32
YS-SFI02004-4	20	4	2.381	34	57	11	46	45	40	5.5	9.5	5.5	M6	1x4	1066	2987	37
YS-SFI0205T-4		5.08	3.175	34	57	11	51	45	40	5.5	9.5	5.5	M6	1x4	1550	3875	39
YS-SFI02504-4	25	4	2.381	40	63	11	46	51	46	5.5	9.5	5.5	M6	1x4	1180	3795	43
YS-SFI0255T-4		5.08	3.175	40	63	11	51	51	46	5.5	9.5	5.5	M8	1x4	1724	4903	45
YS-SFI03204-4	32	4	2.381	46	72	12	47	0	52	6.5	11	6.5	M6	1x4	1296	4838	49

※Please contact YOSO MOTION if the marked types (●) are required.

SFM Series Specifications (Design for Milling)

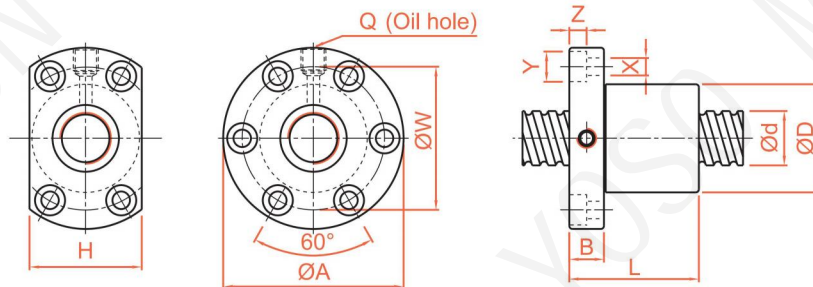

Model No.	d	l	Da	Dimension											Load Rating		K gf/μm
				D	A	B	L	W	H	X	Y	Z	Q	n	Ca (kgf)	Coa (kgf)	
YS-SFM03205-4★	32	5	3.175	48	74	12	52	60	60	6.5	11	6.5	M8	1x4	1922	6343	53
YS-SFM0325T-4★		5.08	3.175	48	74	12	53	60	60	6.5	11	6.5	M8	1x4	1922	6343	53

※ ☆ Left helix available

YOSO MOTION BALL SCREW

2-4 Rolled Ball Screw Series

YS-SFV Series Specifications

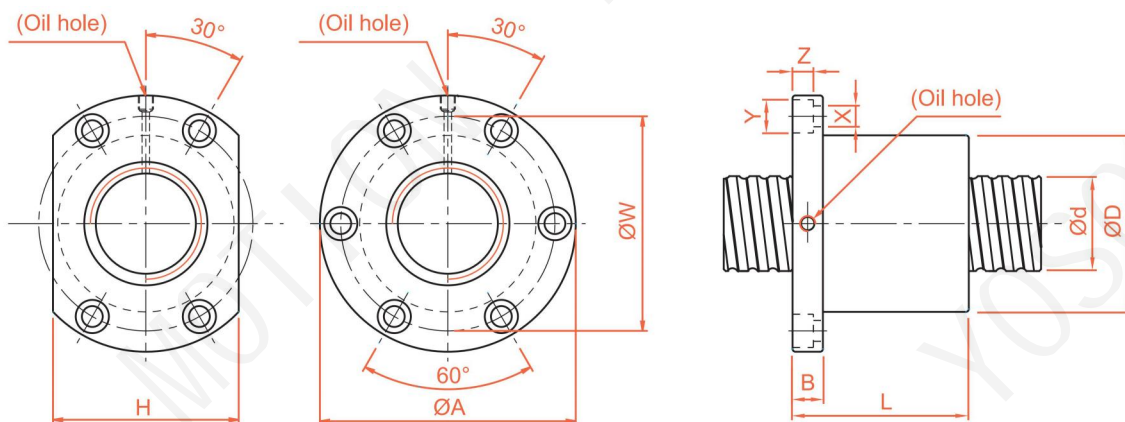

Unit : mm

Model No.	d	l	Da	Dimension											Load Rating		K kgf/μm
				D	A	B	L	W	H	X	Y	Z	Q	n	Ca (kgf)	Coa (kgf)	
YS-SFV01205-2.8	12	5	2.5	30	50	10	42	40	32	4.5	8	4.5	M6	2.8x1	661	1316	19
YS-SFV01210-2.7		10	2.5	30	50	10	53	40	32	4.5	8	4.5	M6	2.7x1	623	1241	18
YS-SFV01604-3.8	16	4	2.381	34	57	11	45	45	34	5.5	9.5	5.5	M6	3.8x1	931	2285	31
YS-SFV01605-4.8		5	3.175	40	63	11	58	51	42	5.5	9.5	5.5	M6	4.8x1	1614	3662	40
YS-SFV01610-2.7		10	3.175	40	63	11	56	51	42	5.5	9.5	5.5	M6	2.7x1	1008	2161	24
YS-SFV02004-4.8	20	4	2.381	40	60	10	50	50	40	4.5	8	4	M6	4.8x1	1247	3584	45
YS-SFV02005-4.8		5	3.175	44	67	11	57	55	52	5.5	9.5	5.5	M6	4.8x1	1814	4650	47
YS-SFV02020-1.8		20	3.175	46	74	13	70	59	46	6.6	11	6.5	M6	1.8x1	764	1758	19
YS-SFV02505-4.8	25	5	3.175	50	73	11	55	61	52	5.5	9.5	5.5	M8	4.8x1	2017	5884	56
YS-SFV02525-1.8		25	3.175	50	73	13	83	61	52	5.5	9.5	5.5	M8	1.8x1	843	2199	22
YS-SFV03204-4.8	32	4	2.381	54	81	12	50	67	64	6.6	11	6.5	M6	4.8x1	1517	5806	62
YS-SFV03205-4.8		5	3.175	58	85	12	56	71	64	6.6	11	6.5	M8	4.8x1	2249	7612	66
YS-SFV03210-4.8		10	6.35	74	108	15	96	90	82	9	14	9	M8	4.8x1	5620	14649	76
YS-SFV04005-4.8	40	5	3.175	67	101	15	59	83	72	9	14	8.5	M8	4.8x1	2468	9586	76
YS-SFV04010-4.8		10	6.35	82	124	18	100	102	94	11	17.5	11	M8	4.8x1	6316	18600	90
YS-SFV04020-2.7		20	6.35	82	124	18	100	102	90	11	17.5	11	M8	2.7x1	3935	10893	56
YS-SFV05005-4.8	50	5	3.175	80	114	15	60	96	82	9	14	8.5	M8	4.8x1	2698	12053	87
YS-SFV05010-4.8		10	6.35	93	135	16	93	113	98	11	17.5	11	M8	4.8x1	7023	23537	106
YS-SFV05020-2.7		20	9.525	105	152	28	121	128	110	14	20	13	M8	2.7x1	7336	19700	68
YS-SFV06310-4.8	63	10	6.35	108	154	22	105	130	110	14	20	13	M8	4.8x1	7860	30430	126
YS-SFV06320-2.7		20	9.525	122	180	28	120	150	130	18	26	17.5	M8	2.7x1	8162	24741	80
YS-SFV08010-4.8	80	10	6.35	130	176	22	105	152	132	14	20	13	M8	4.8x1	8593	38344	145
YS-SFV08020-4.8		20	9.525	143	204	28	180	172	148	18	26	18	M8	4.8x1	15103	57296	168
YS-SFV08020-7.6		20	9.525	143	204	28	240	172	148	18	26	18	M8	3.8x2	22423	90719	260

※Please contact YOSO MOTION if the marked types (●) are required.

YS-SFY Series Specifications

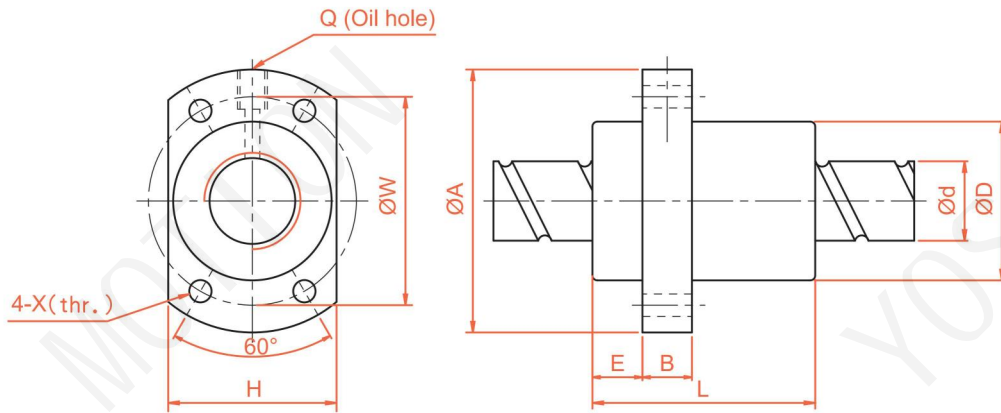

Unit : mm

Large Lead Model No.	d	l	Da	Dimension										Load Rating		K kgf/μm
				D	A	E	B	L	W	H	X	Q	n	Ca (kgf)	Coa (kgf)	
YS-SFY01616-3.6	16	16	2.778	32	53	10.1	10	45	42	34	4.5	M6	1.8x2	1073	2551	31
YS-SFY02020-3.6	20	20	3.175	39	62	13	10	52	50	41	5.5	M6	1.8x2	1387	3515	37
YS-SFY02525-3.6	25	25	3.969	47	74	15	12	64	60	49	6.6	M6	1.8x2	2074	5494	45
YS-SFY03232-3.6	32	32	4.762	58	92	17	12	78	74	60	9	M6	1.8x2	3021	8690	58
YS-SFY04040-3.6	40	40	6.35	73	114	19.5	15	99	93	75	11	M6	1.8x2	4831	14062	70
YS-SFY05050-3.6 •	50	50	7.938	90	135	21.5	20	117	112	92	14	M6	1.8x2	7220	21974	86
Twin Lead Model No.	d	l	Da	Dimension										Ca (kgf)	Coa (kgf)	K kgf/μm
YS-SFY01632-1.6	16	32	2.778	32	53	10.1	10	42.5	42	34	4.5	M6	0.8x2	493	1116	11
YS-SFY02040-1.6	20	40	3.175	39	62	13	10	48	50	41	5.5	M6	0.8x2	653	1597	15
YS-SFY02550-1.6	25	50	3.969	47	74	15	12	58	60	49	6.6	M6	0.8x2	976	2495	19
YS-SFY03264-1.6	32	64	4.762	58	92	17	12	71	74	60	9	M6	0.8x2	1374	3571	22
YS-SFY04080-1.6	40	80	6.35	73	114	19.5	15	90	93	75	11	M6	0.8x2	2273	6387	29
YS-SFY050100-1.6 •	50	100	7.938	90	135	21.5	20	111	112	92	14	M6	0.8x2	3398	9980	35

※Please contact YOSO MOTION if the marked types (●) are required.

YOSO MOTION BALL SCREW

2-4 Rolled Ball Screw Series

YS-XSY Series Specifications

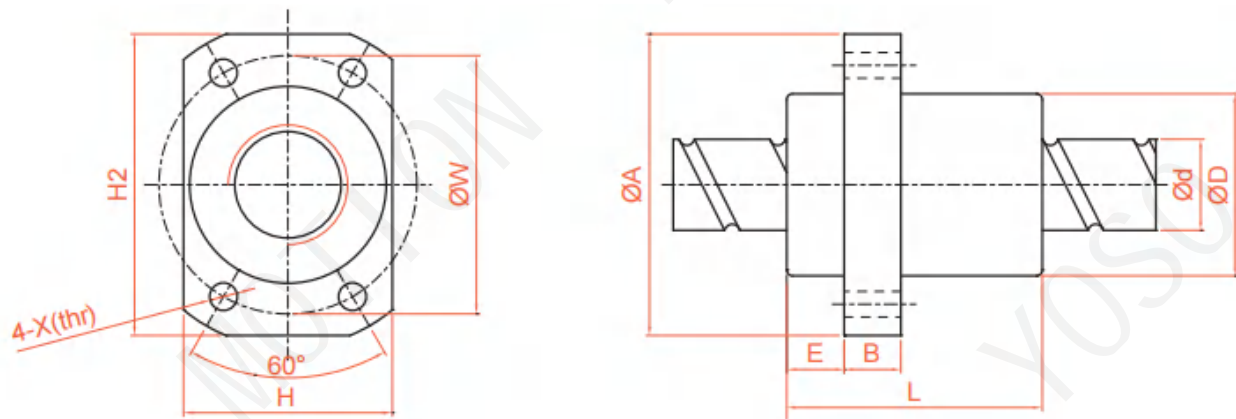

Unit : mm

Model No.	d	l	Da	Dimension										Load Rating		K kgf/μm
				D	A	E	B	L	W	H	H2	X	n	Ca(kgf)	Coa (kgf)	
YS-XSYR01220A2D-00	12	20	2.5	24	41	3.8	5	50	32	24	36	4.5	1.8x2	777	1718	13

YS-SCNI/SCI Series Specifications

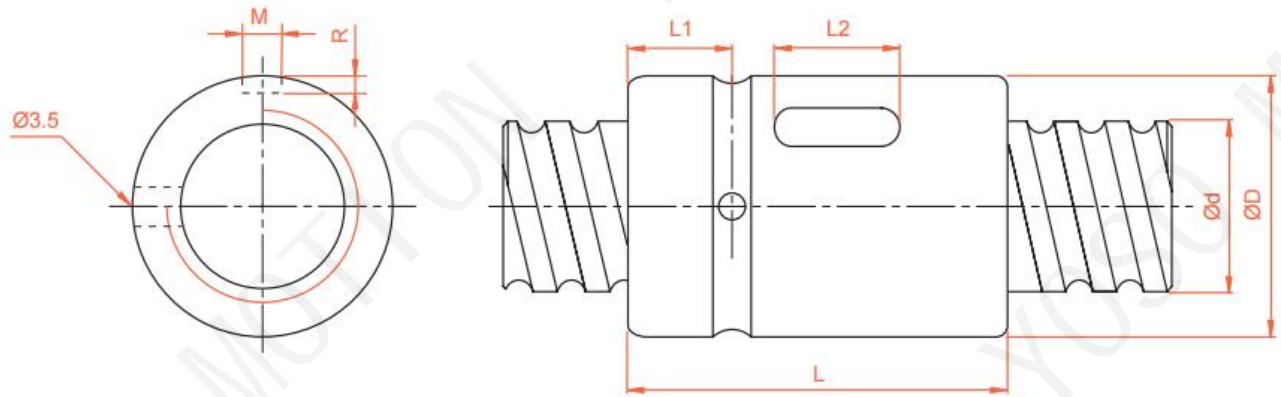

Unit : mm

Model No.	d	l	Da	Dimension							Load Rating		K kgf/μm
				D	L	L1	L2	V1	R	n	Ca(kgf)	Coa(kgf)	
YS-SCNI 01605-4	16	5	3.175	00	45	9	20	5	3	1x4	1380	3052	33
YS-SCNI 02005-4	20	5	3.175	34	45	9	20	5	3	1x4	1551	3875	39
YS-SCNI 02505-4	25	5	3.175	40	45	9	20	5	3	1x4	1724	4904	45
YS-SCNI 02510-4		10	4.762	46	85	13	30	5	3	1x4	2954	7295	51
YS-SCNI 03205-4	32	5	3.175	46	45	9	20	5	3	1x4	1922	6343	52
YS-SCNI 03210-4		10	6.35	54	85	13	30	5	3	1x4	4805	12208	62
YS-SCNI 04005-4	40	5	3.175	56	45	9	20	5	3	1x4	2110	7988	59
YS-SCNI 04010-4		10	6.35	62	85	13	30	5	3	1x4	5399	15500	72
YS-SCNI 05010-4 •	50	10	6.35	72	85	13	30	5	3	1x4	6004	19614	83
YS-SCNI06310-4 •	63	10	6.35	85	85	13	30	6	3.5	1x4	6719	25358	95
YS-SCNI08010-4 •	80	10	6.35	105	85	13	30	8	4.5	1x4	7346	31953	109
YS-SCI 01604-4	16	4	2.381	30	40	9	15	3	1.5	1x4	973	2406	32
YS-SCI 02004-4	20	4	2.381	34	40	9	15	3	1.5	1x4	1066	2987	37
YS-SCI 02504-4	25	4	2.381	40	40	9	15	3	1.5	1x4	1180	3795	43
YS-SCI 03204-4	32	4	2.381	46	40	9	15	3	1.5	1x4	1296	4838	49

※Please contact YOSO MOTION if the marked types (●) are required.

YOSO MOTION BALL SCREW

2-4 Rolled Ball Screw Series

YS-SFK Series Specifications

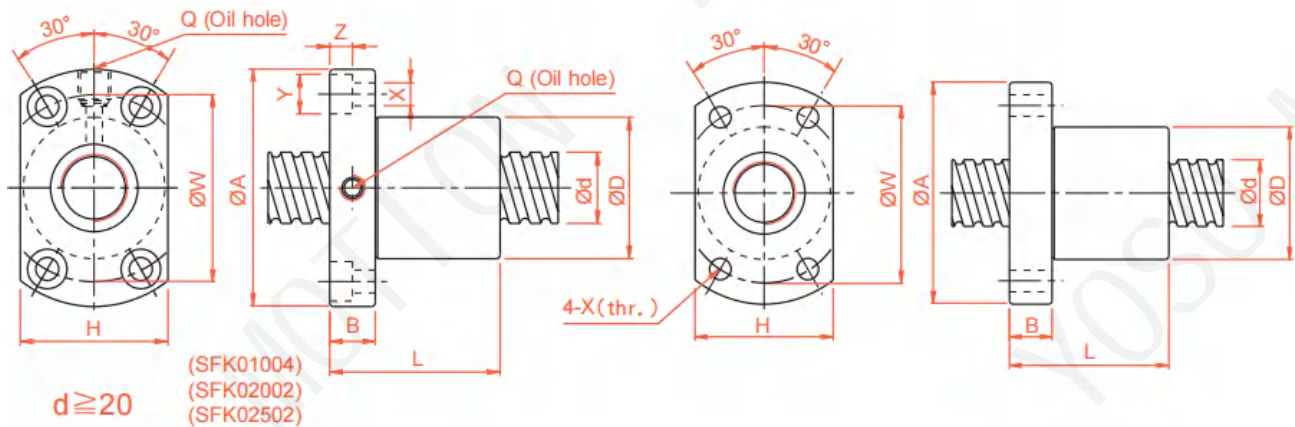

Unit : mm

Model No.	d	l	Da	Dimension											Ca (kgf)	Coa (kgf)	K (kgf/μm)
				D	A	B	L	W	H	X	Y	Z	Q	n			
YS-SFK00601	6	1	0.8	12	24	3.5	15	18	16	3.4	-	-	-	1x3	111	224	9
YS-SFK00801		1	0.8	14	27	4	16	21	18	3.4	-	-	-	1x4	161	403	14
YS-SFK00802	8	2	1.2	14	27	4	16	21	18	3.4	-	-	-	1x3	222	458	13
YS-SFK0082.5		2.5	1.2	16	29	4	26	23	20	3.4	-	-	-	1x3	221	457	13
YS-SFK01002		2	1.2	18	35	5	28	27	22	4.5	-	-	-	1x3	243	569	15
YS-SFK01004	10	4	2	26	46	10	34	36	28	4.5	8	4.5	M6	1x3	468	905	17
YS-SFK01202	12	2	1.2	20	37	5	28	29	24	4.5	-	-	-	1x4	334	906	22
YS-SFK01402	14	2	1.2	21	40	6	23	31	26	5.5	-	-	-	1x4	354	1053	24

Unit : mm

Model No.	d	l	Da	Dimension											Ca (kgf)	Coa (kgf)	K (kgf/μm)
				D	A	B	L	W	H	X	Y	Z	Q	n			
YS-XSUR01204T3D-02		4		24	40	6	28	32	25	3.5	-	-	-	1x3	704	1413	-
YS-XSUR01205T3D-00	12	5	2.5	22	37	8	39	29	24	4.5	-	-	-	1x3	702	1409	17

YOSO MOTION BALL SCREW

YS-BSH Series Specifications

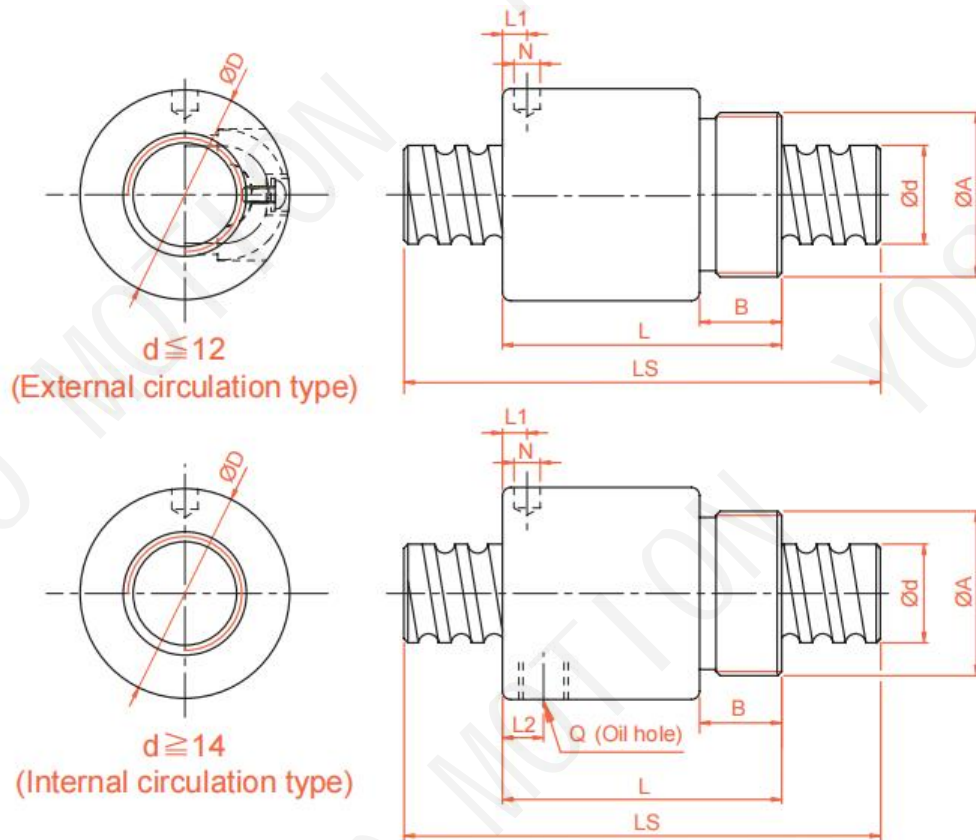

Unit : mm

Model No.	d	l	Da	Dimension									Ca (kgf)	Coa (kgf)	K (kgf/ μ m)
				D	A	B	L	L1	N	L2	Q	n			
YS-BSHR0082.5-2.5	8	2.5	1.2	17.5	M15x1P	7.5	23.5	10	3	-	-	2.5x1	189	381	11
YS-BSHR01002-3.5	10	2	1.2	19.5	M17x1P	7.5	22	3	3.2	-	-	3.5x1	277	664	17
YS-BSHR01004-2.5		4	2	25	M20x1P	10	34	3	3	-	-	2.5x1	400	754	14
YS-BSHR01204-3.5	12	4	2.5	25.5	M20x1P	10	34	13	3	-	-	3.5x1	804	1649	23
YS-BSHR01205-3.5		5	2.5	25.5	M20x1P	10	39	16.25	3	-	-	3.5x1	801	1644	24
YS-BSHR01404-3	14	4	2.5	32.1	M25x1.5P	10	35	11	3	-	-	1x3	748	1609	26
YS-BSHR01604-3	16	4	2.381	29	M22x1.5P	8	32	4	3.2	-	-	1x3	759	1804	24
YS-BSHR01605-3		5	3.175	32.5	M26x1.5P	12	42	19.25	3	-	-	1x3	1077	2289	25
YS-BSHR01610-2		10	3.175	32	M26x1.5P	12	50	3	4	3	M4	1x2	779	1601	14
YS-BSHR02005-3	20	5	3.175	38	M35x1.5P	15	45	20.3	3	-	-	1x3	1211	2906	30
YS-BSHR02505-4	25	5	3.175	43	M40x1.5P	19	69	32.11	3	8	M6	1x4	1724	4904	37
YS-BSHR02510-4		10	4.762	43	M40x1.5P	19	84	8	6	8	M6	1x4	2954	7295	41

※Standard ballnut from $\varnothing 8$ ~ $\varnothing 16$ is assembled without wiper.

SGL-C DISK/CLAMP TYPE/LONGER FLEXIBLE COUPLING

■ SGS-C DISK/CLAMP TYPE/LONGER FLEXIBLE COUPLING

Features :

- Suitable for servo-motor and precision transmission mechanism.
- Single disk ,compact design,low moment of inertiaand zero backlash.
- Allow minor deviation in angularity and end -play.
- Fixed method:Clamp type.Material:Aluminum alloy.

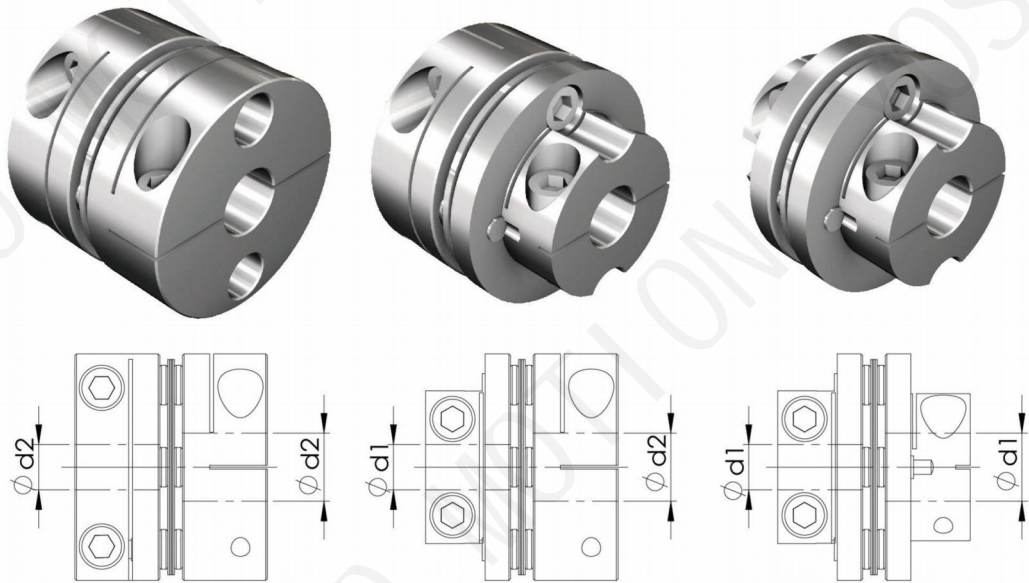

Model No.	$\phi d1$	$\phi d2$
Figure.		
SGS27C	4~6.35	7~10
SGS34C	6~9.525	10~14
SGS40C	8~10	11~16
SGS45C	10~13	14~19
SGS50C	10~16	17~22
SGS57C	12~18	19~24
SGS65C	12~21	22~28

■ SGS-C DISK/CLAMP TYPE/LONGER FLEXIBLE COUPLING

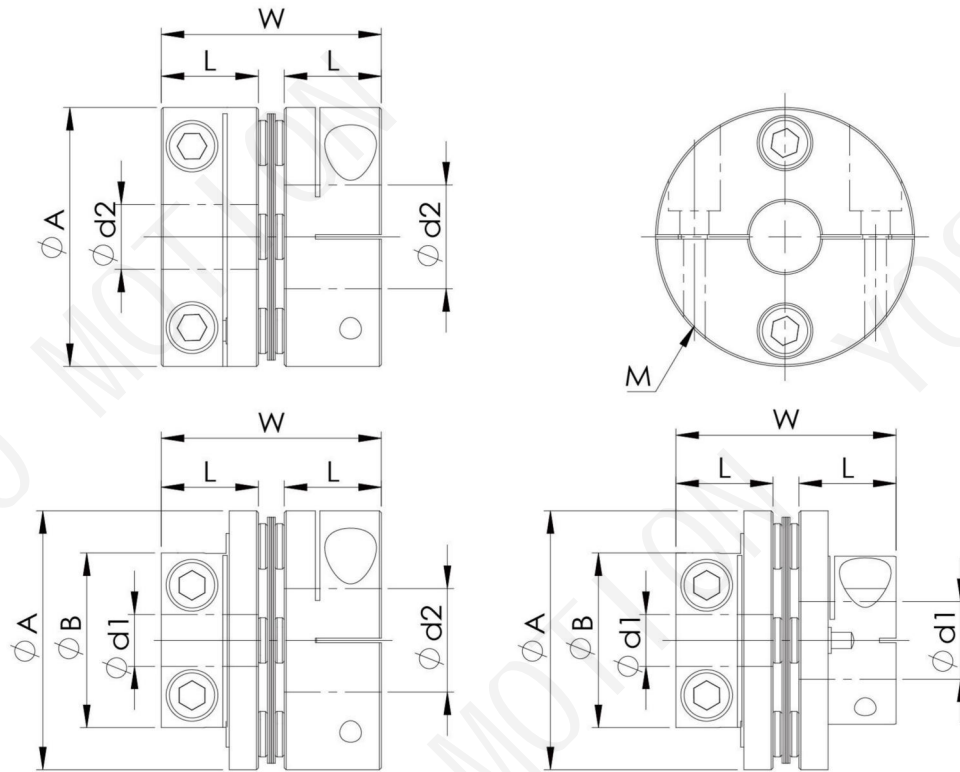

Dimension

Catalog Number	φA	φB	L	W	φd1xφd2		Setscrew Max.torque	
					Stock bores. (H8)		M	kgf-cm
					φd1	φd2		
SGS-27C	27	20	11	24.5	4~6.35	7~10	4-M3	20
SGS-34C	34	23	12	27	6~9.525	10~14	4-M3	20
SGS-40C	40	27	15	34	8~10	11~16	4-M4	35
SGS-45C	45	34	15	34	10~13	14~19	4-M4	35
SGS-50C	50	40	20	45	10~16	17~22	4-M5	75
SGS-57C	57	45	20	45	12~18	19~24	4-M5	75
SGS-65C	65	50	24	54	12~21	22~28	4-M6	100

Specifications

Catalog Number	Rated Torque (N.m)	Max Torque	Max Rotational Frequency (min-1)	Moment of Inertia (Kg.m2)	Errors of Eccentricity (mm)	Errors of Angularity (°)	Errors of Shaft End-Play (mm)	Weight (g)
SGS-27C	2	4	10000	3.1x10 ⁻⁶	0.02	1°	±0.15	-
SGS-34C	5	10		8.0x10 ⁻⁶			±0.2	-
SGS-40C	7	14		2.0x10 ⁻⁵			±0.25	-
SGS-45C	10	20		2.8x10 ⁻⁵			±0.3	-
SGS-50C	16	32		6.6x10 ⁻⁵			±0.35	-
SGS-57C	26	52		9.8x10 ⁻⁵			±0.4	-
SGS-65C	60	120		24.0x10 ⁻⁵			±0.45	-

SGL-C DISK/CLAMP TYPE/LONGER FLEXIBLE COUPLING

■ SGL-C DISK/CLAMP TYPE/LONGER FLEXIBLE COUPLING

Features:

- Suitable for servo-motor and precision transmission mechanism.
- double disks ,low moment of inertia and zero backlash.
- Allow minor deviation in eccentricity ,angularity and end -play.
- Fixed method:Clamp type.Material:Aluminum alloy.

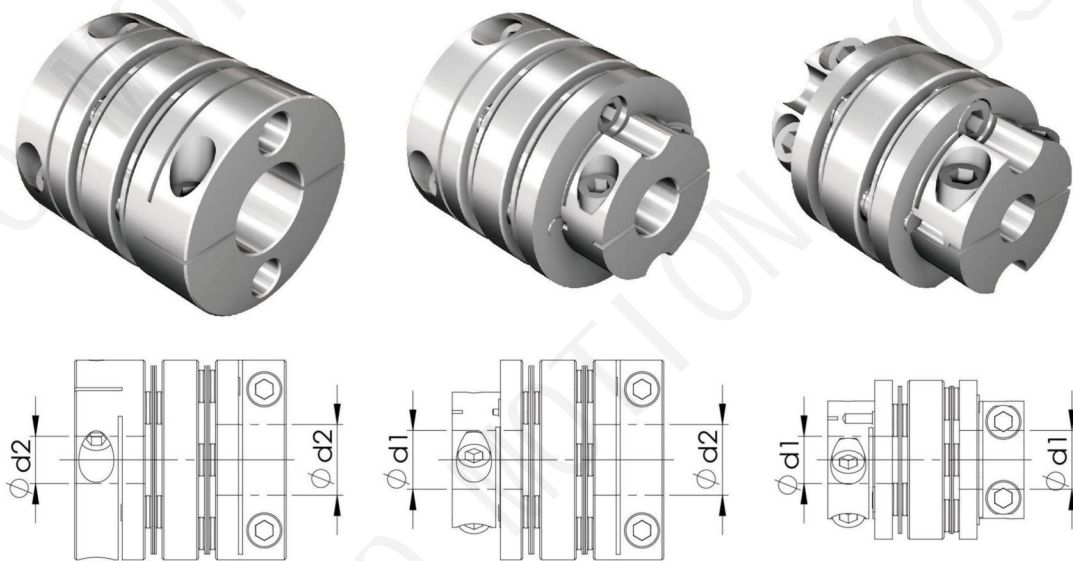

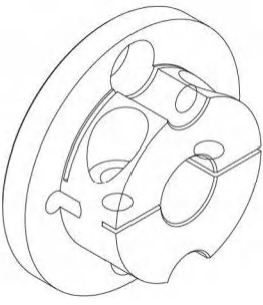
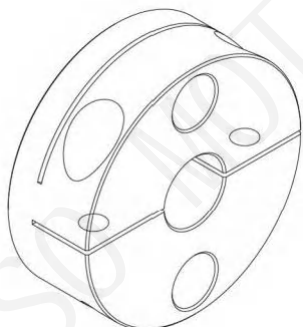
Model No.	$\phi d1$	$\phi d2$
Figure.		
SGL27C	4~6.35	7~10
SGL34C	6~9.525	10~14
SGL40C	8~10	11~16
SGL45C	10~13	14~19
SGL50C	10~16	17~22
SGL57C	12~18	19~24
SGL65C	12~21	22~28

■ SGL-C DISK/CLAMP TYPE/LONGER FLEXIBLE COUPLING

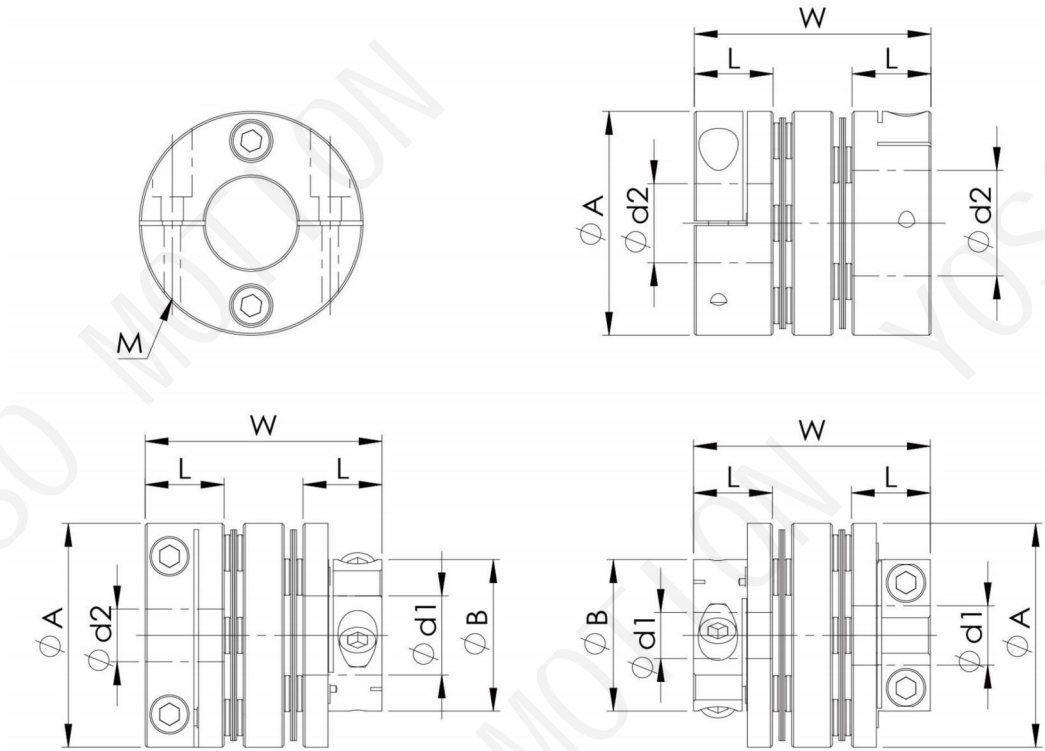

Dimension

Catalog Number	φA	φB	L	W	φd1xφd2		Setscrew Max.torque	
					Stock bores. (H8)		M	kgf-cm
					φd1	φd2		
SGL-27C	27	20	11	24.5	4~6.35	7~10	4-M3	20
SGL-34C	34	23	12	27	6~9.525	10~14	4-M3	20
SGL-40C	40	27	15	34	8~10	11~16	4-M4	35
SGL-45C	45	34	15	34	10~13	14~19	4-M4	35
SGL-50C	50	40	20	45	10~16	17~22	4-M5	75
SGL-57C	57	45	20	45	12~18	19~24	4-M5	75
SGL-65C	65	50	24	54	12~21	22~28	4-M6	100

Specifications

Catalog Number	Rated Torque (N.m)	Max Torque	Max Rotational Frequency (min-1)	Moment of Inertia (Kg.m2)	Errors of Eccentricity (mm)	Errors of Angularity (°)	Errors of Shaft End-Play (mm)	Weight (g)
SGL-27C	2	4	10000	3.1x10 ⁻⁶	0.15	2°	±0.15	-
SGL-34C	5	10		8.0x10 ⁻⁶	0.17		±0.2	-
SGL-40C	7	14		2.0x10 ⁻⁵	0.22		±0.25	-
SGL-45C	10	20		2.8x10 ⁻⁵	0.22		±0.3	-
SGL-50C	16	32		6.6x10 ⁻⁵	0.24		±0.35	-
SGL-57C	26	52		9.8x10 ⁻⁵	0.27		±0.4	-
SGL-65C	60	120		24.0x10 ⁻⁵	0.35		±0.45	-

Motor Bracket MBCB12

Motor Bracket MBCB12

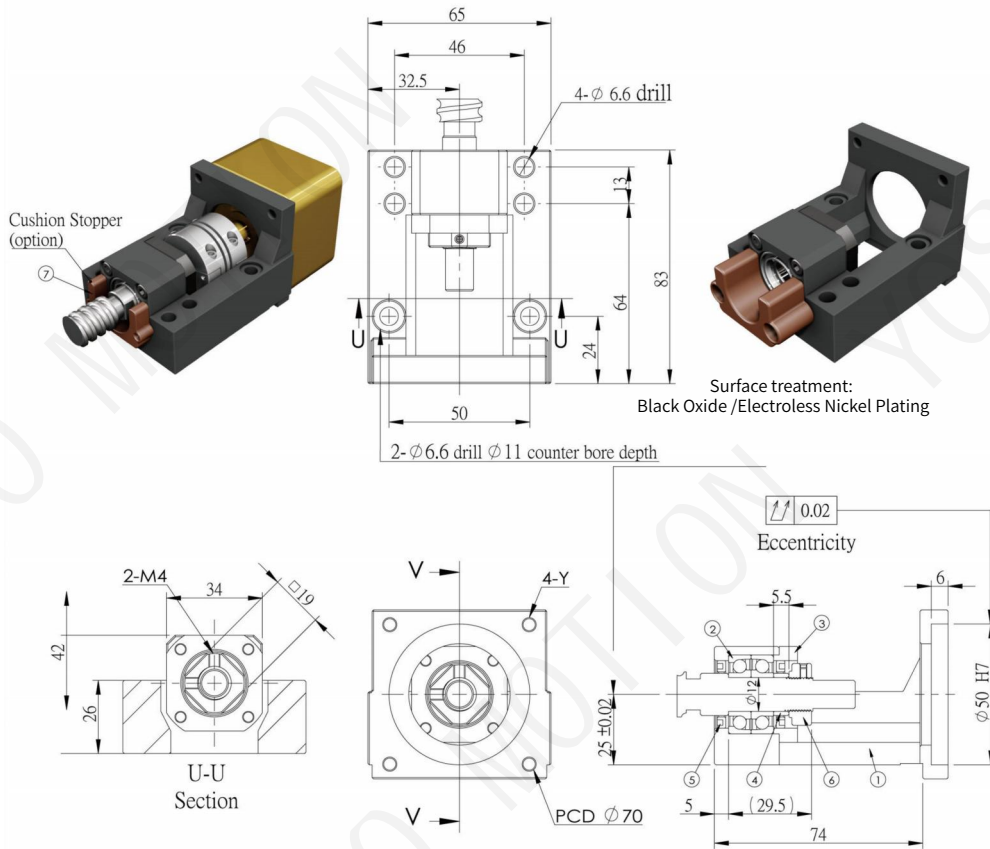

No.	Part name	Qty
1	Housing	1
2	7001 Bearing	1set
3	Holding lid	1
4	Collar	2
5	Seal	2
6	Lock nut	1set
7	Cushion Stopper (option)	1

Unit:mm

Model No.	Y	Weight (Kgs)	Support unit	Suggest Coupling
			Supported-side	
MBCB12-D	M5	0.8	BF12	SGS 34C
MBCB12-	M4			

Note:

- 1.The matched bearing in the support unit has already done the preload
- 2.The matched P5 bearings are assembled in DF way,which is the most suitable for ball screw use.

Motor Bracket MBCB15

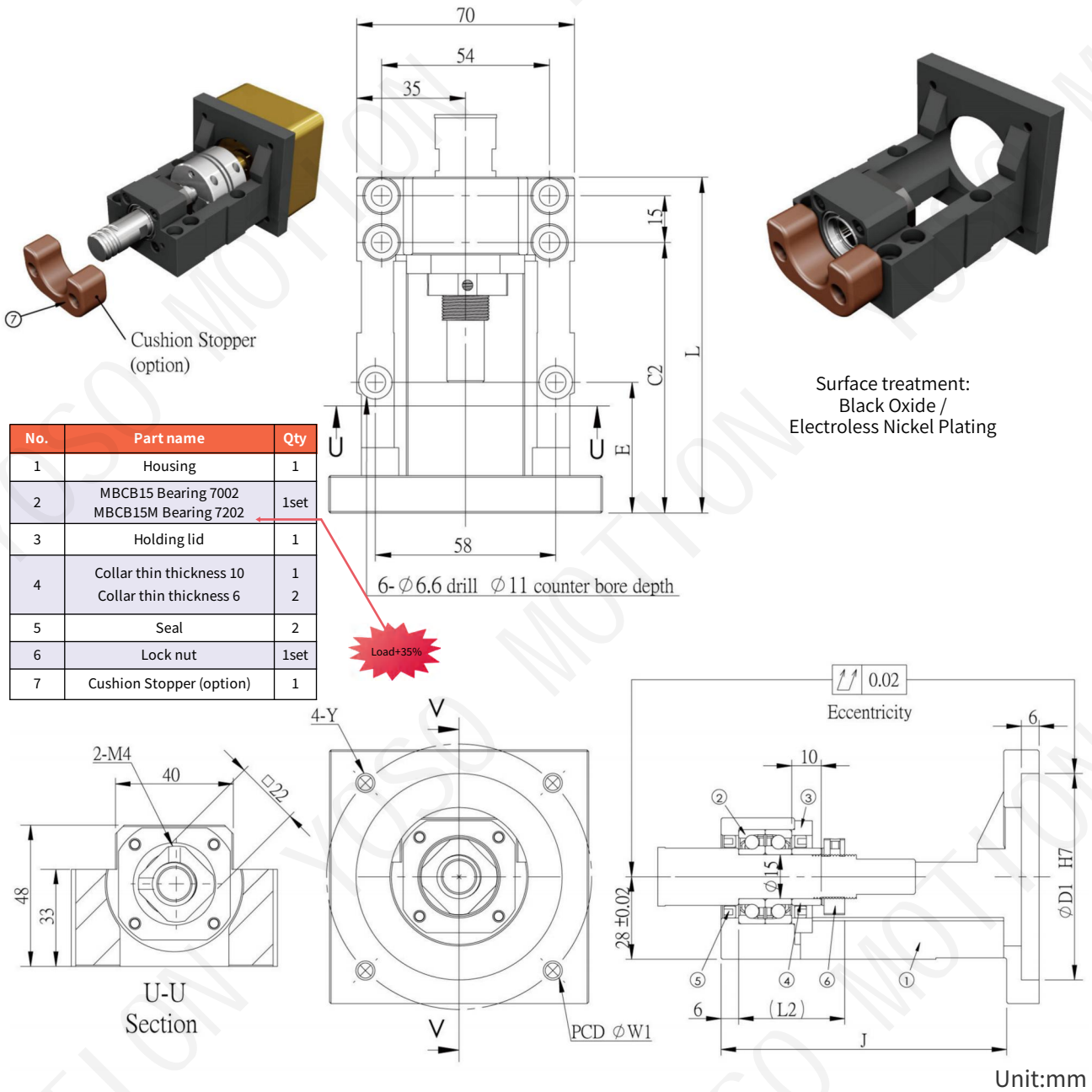

Model No.	D1	W1	Y	L	L2	E	C2	J	Weight (Kgs)	Support unit	Suggest Coupling
										Supported-side	
MBCB15-D	50	70	M5	98	36	32	77	89	0.98	BF15	SGS 34C
MBCB15-DP			M4								SGS 40C
MBCB15-E	70	90	M6	108		42	87	97	1.39		SGS 40C
MBCB15-EP			M5		SGS 45C						
MBCB15M-E			M6	110	40	44	89	99	—		—
MBCB15M-EP			M5								

Note:

- 1.The matched bearing in the support unit has already done the preload
- 2.The matched P5 bearings are assembled in DF way,which is the most suitable for ball screw use.

Motor Bracket MBCE10/12、MBCF10/12

Motor Bracket MBCE10/12、MBCF10/12

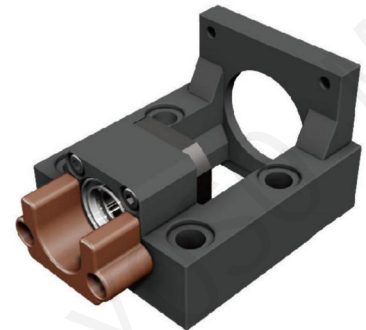
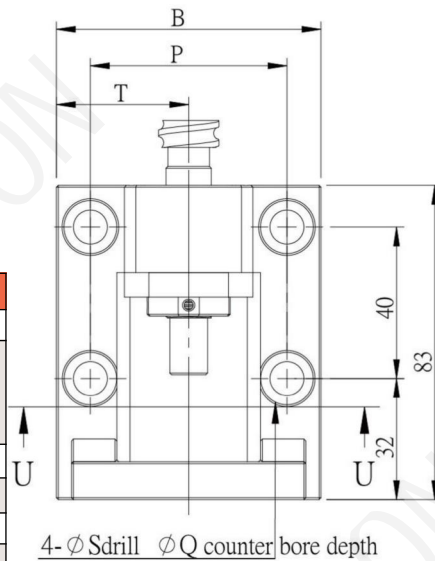
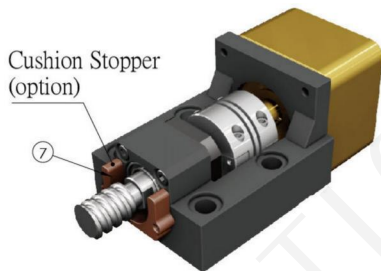

Surface treatment:
Black Oxide /
Electroless Nickel Plating

No.	Part name	Qty
1	Housing	1
2	Bearing MBC*10 with bearings 7000	1 set
3	Holding lid	1
4	Collar	2
5	Seal	2
6	Lock nut	1set
7	Cushion Stopper (option)	1

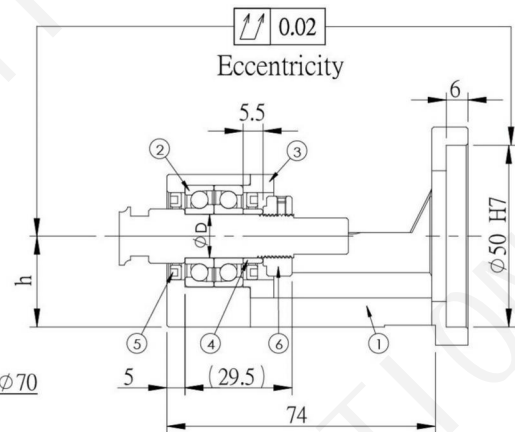
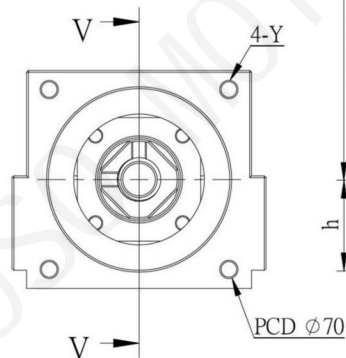
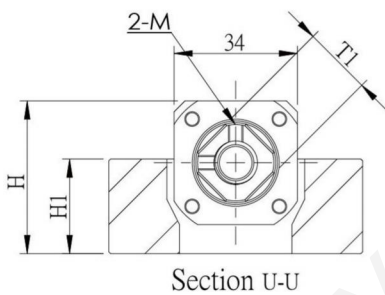

Unit:mm

Model No.	B	P	T	H	H1	h ±0.02	D	T1	M	Y	S	Q	Weight (Kgs)	S support unit	Suggest Coupling
														Supported-side	
MBCE10-D	70	52	35	42	26	25	10	16	M3	M5	9	14	-	EF10	SGS 34C
MBCE10-DP										M4			-	AF 10	
MBCE12-D										M5			0.84	EF12	
MBCE12-DP										M4			0.86	AF 12	
MBCF10-D	63	50	31.5	37	21	20	10	16	M3	M5	6.6	11	-	LF12	
MBCF10-DP										M4			-	LFA 15	
MBCF12-D										M5			-		
MBCF12-DP										M4			-		

Note:

- 1.The matched bearing in the support unit has already done the preload
- 2.The matched P5 bearings are assembled in DF way,which is the most suitable for ball screw use.

■ Illustration for MBCF10/12

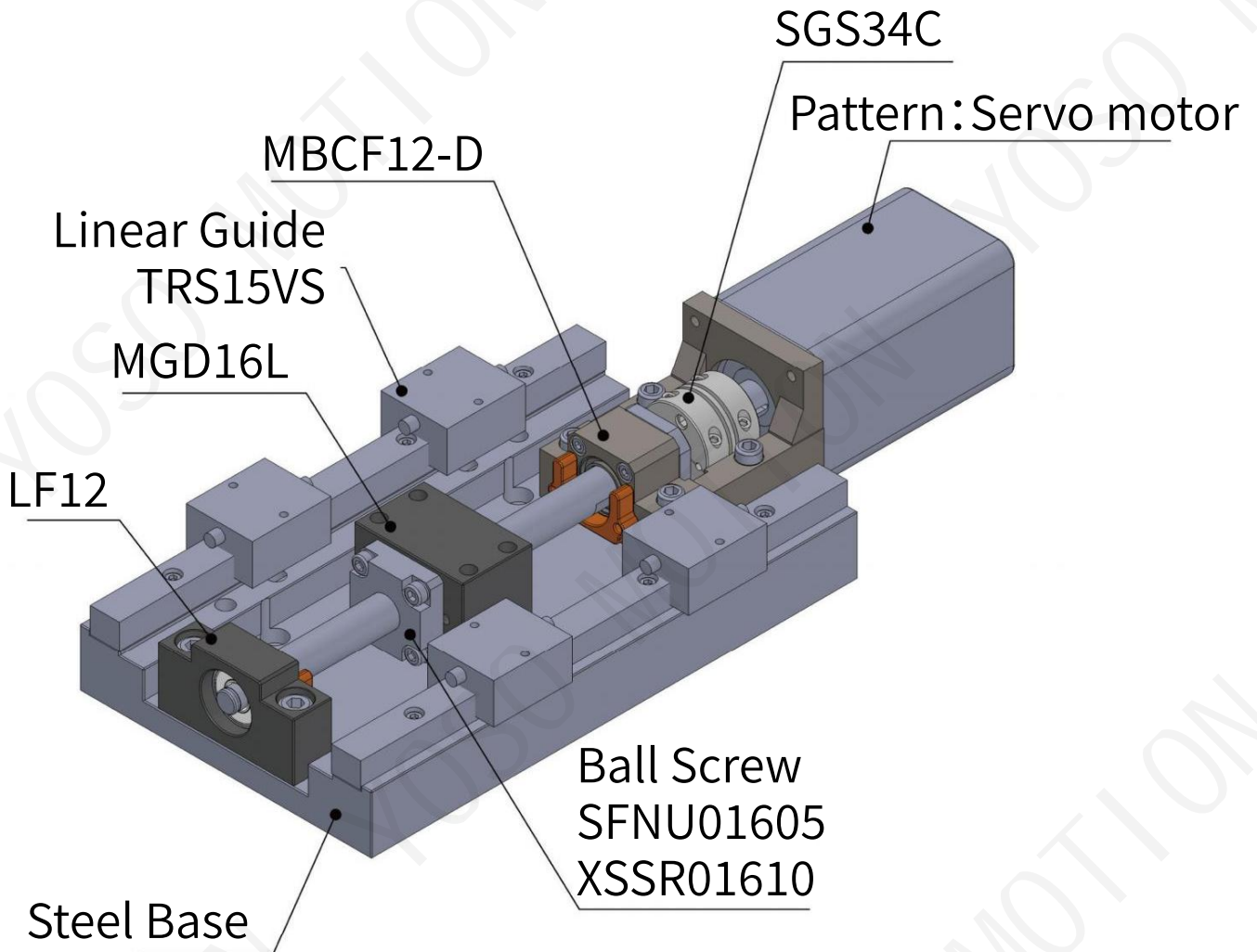

Motor Bracket MBCE15

Motor Bracket MBCE15

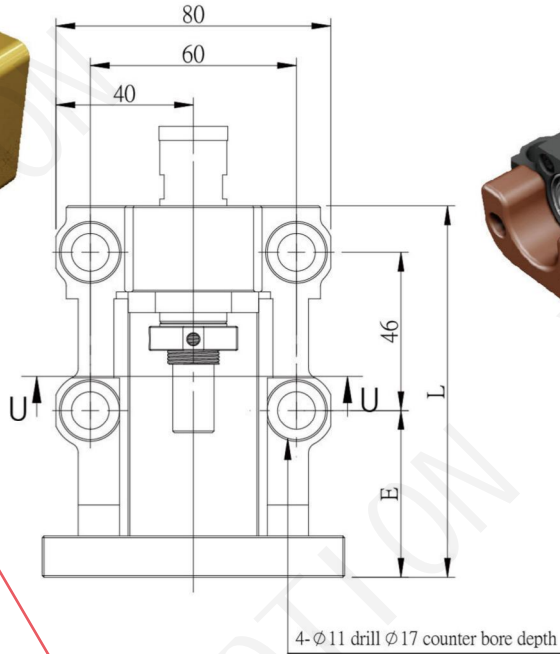
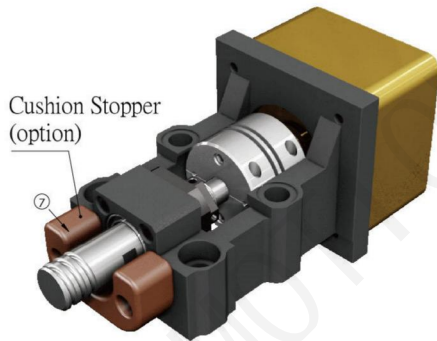

No.	Part name	Qty
1	Housing	1
2	Bearing MBCE15 with bearings 7002 MBCE15M with bearings	1set
3	Holding lid	1
4	Collar	2
5	Seal	2
6	Lock nut	1set
7	Cushion Stopper(option)	1

Load+35%

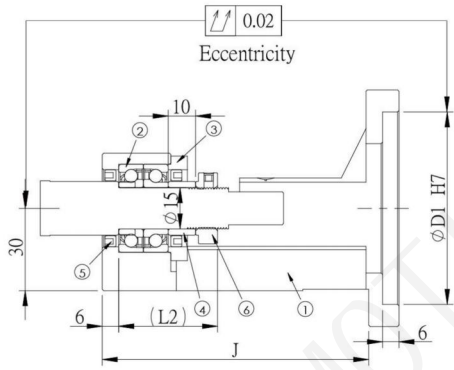
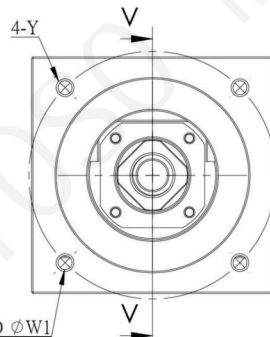
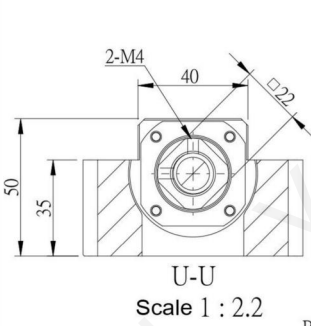

Unit:mm

Model No.	D1	W1	Y	L	L2	E	J	Weight (Kgs)	Support unit Supported-side	Suggest Coupling
MBCE15-D	50	70	M5	98	36	38.5	平底	1.09	EF 15 AF 15	SGS 34C SGS 40C
MBCE15-DP			M4					1.07		
MBCE15-E	70	90	M6	108		48.5	97	1.52		
MBCE15-EP			M5		1.52					
MBCE15M-E			M6	—						
MBCE15M-EP			M5	—						

Note:

- 1.The matched bearing in the support unit has already done the preload
- 2.The matched P5 bearings are assembled in DF way,which is the most suitable for ball screw use.

Motor Bracket MBCA15/20

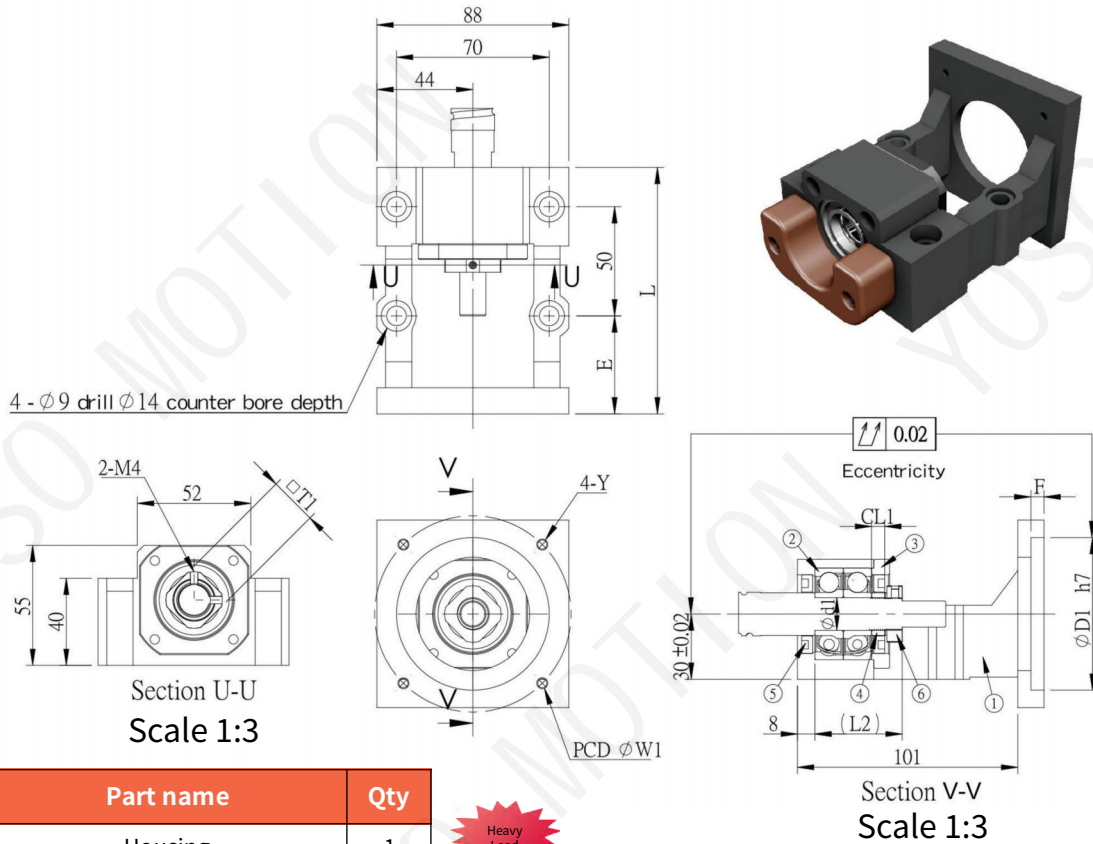

No.	Part name	Qty
1	Housing	1
2	Bearing MBCA15(7302A) MBCA20(7004A)	1set
3	Holding lid	1
4	Collar	2
5	Seal	2
6	Lock nut	1set
7	Cushion Stopper (option)	1

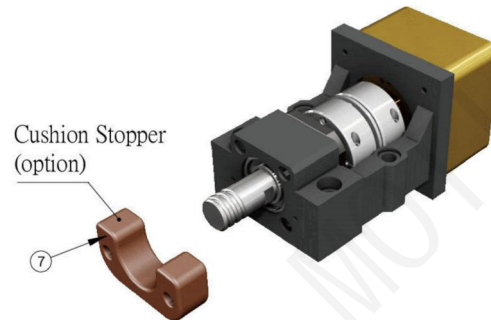

Unit:mm

Model No.	D1	W1	Y	L	Shaft diameter d1	CL1	L2	E	F	T1	Weight (Kgs)	Support unit Supported-side	Suggest Coupling
MBCA15-E	70	90	M6	115	15	6	40	47	8	22	-	AK15/AF15	SGS 50C
MBCA15-EP	70	90	M5	113				45	6				
MBCA15-X	80	100	M6	115	47	8	-						
MBCA20-E	70	90	M6	115	20	8	43	47	8	30	-	AK20/AF20	
MBCA20-EP	70	90	M5	113				45	6				
MBCA20-X	80	100	M6	115	47	8	-						

Note:

- 1.The matched bearing in the support unit has already done the preload
- 2.The matched P5 bearings are assembled in DF way,which is the most suitable for ball screw use.

Illustration for MBCA15/20

■ Illustration for MBCA15

Fixed+Fixed

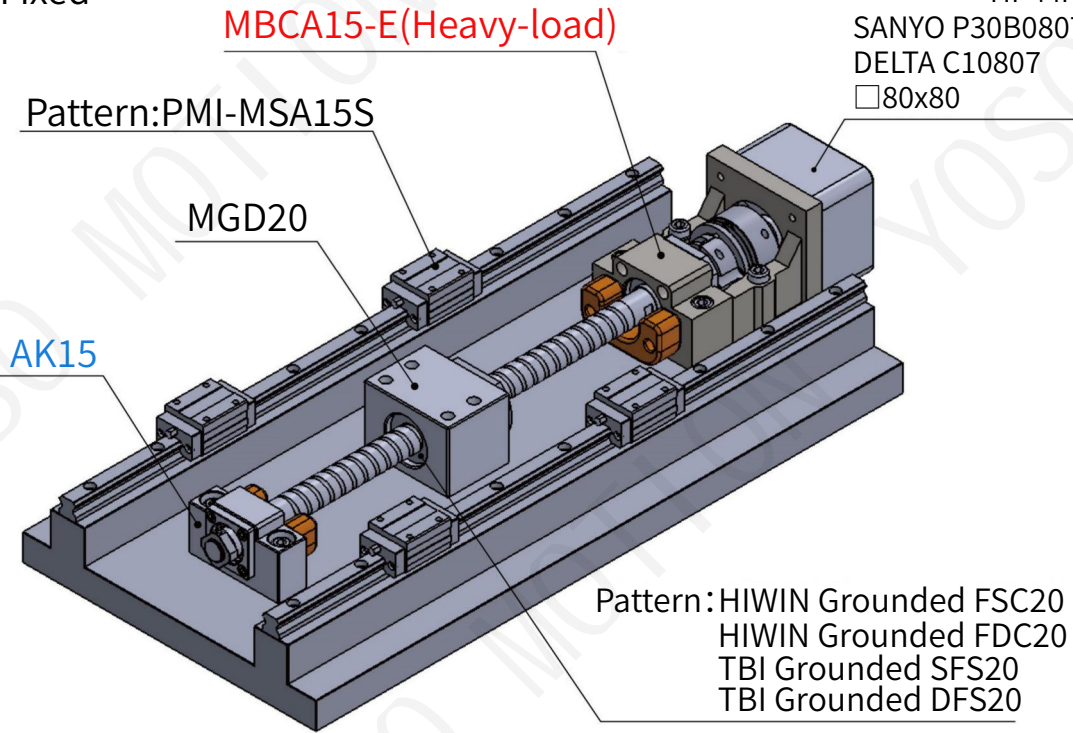

Pattern: Servo motor

Yaskawa SGMAH-08A

Mitsubishi HF-KP73

HF-MP73

SANYO P30B08075

DELTA C10807

□80x80

Fixed+Supported

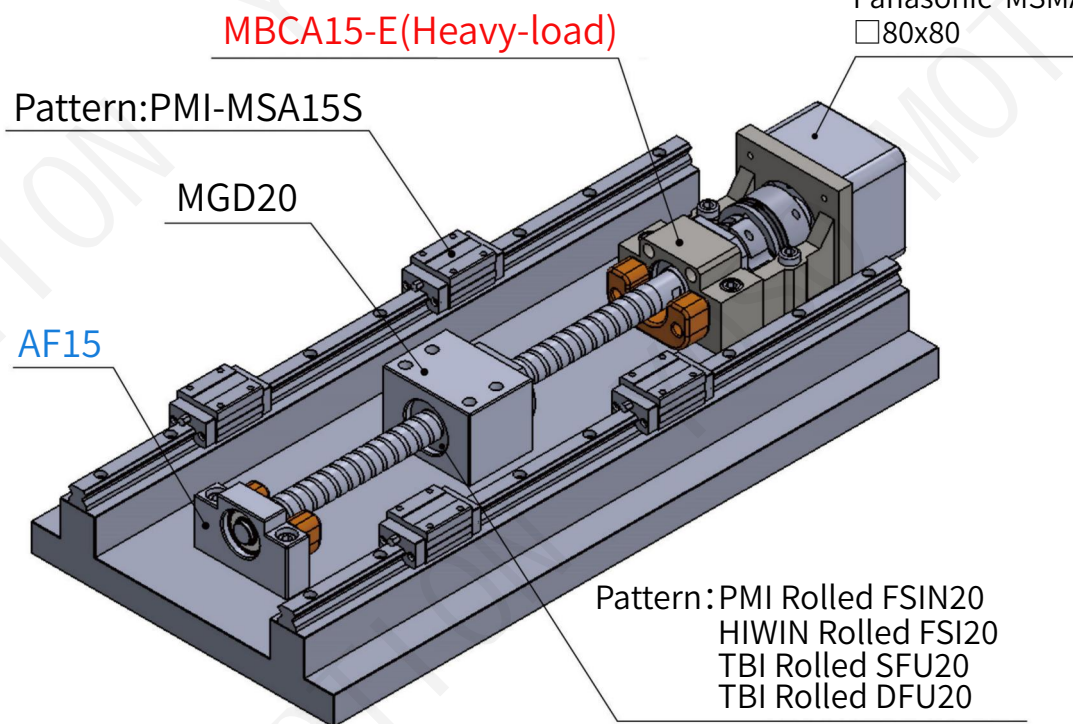

Pattern: Servo motor

Panasonic MSMA082

□80x80

■ Illustration for MBCA20

Fixed+Fixed

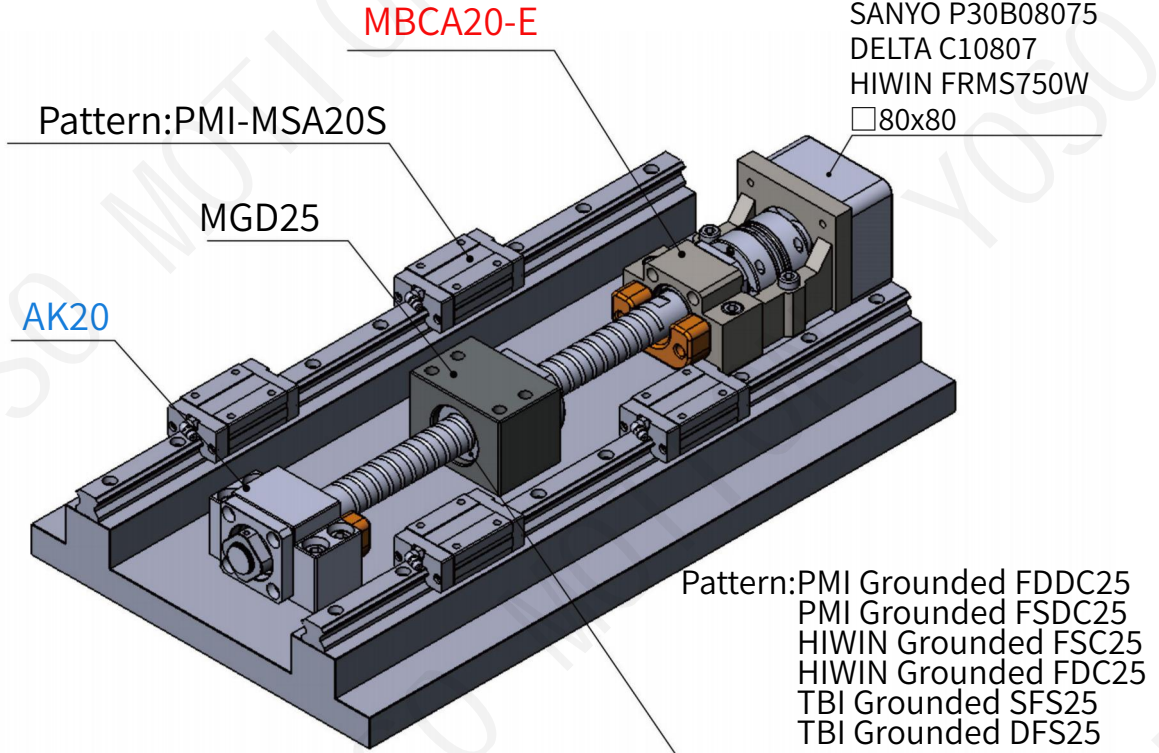

Fixed+Supported

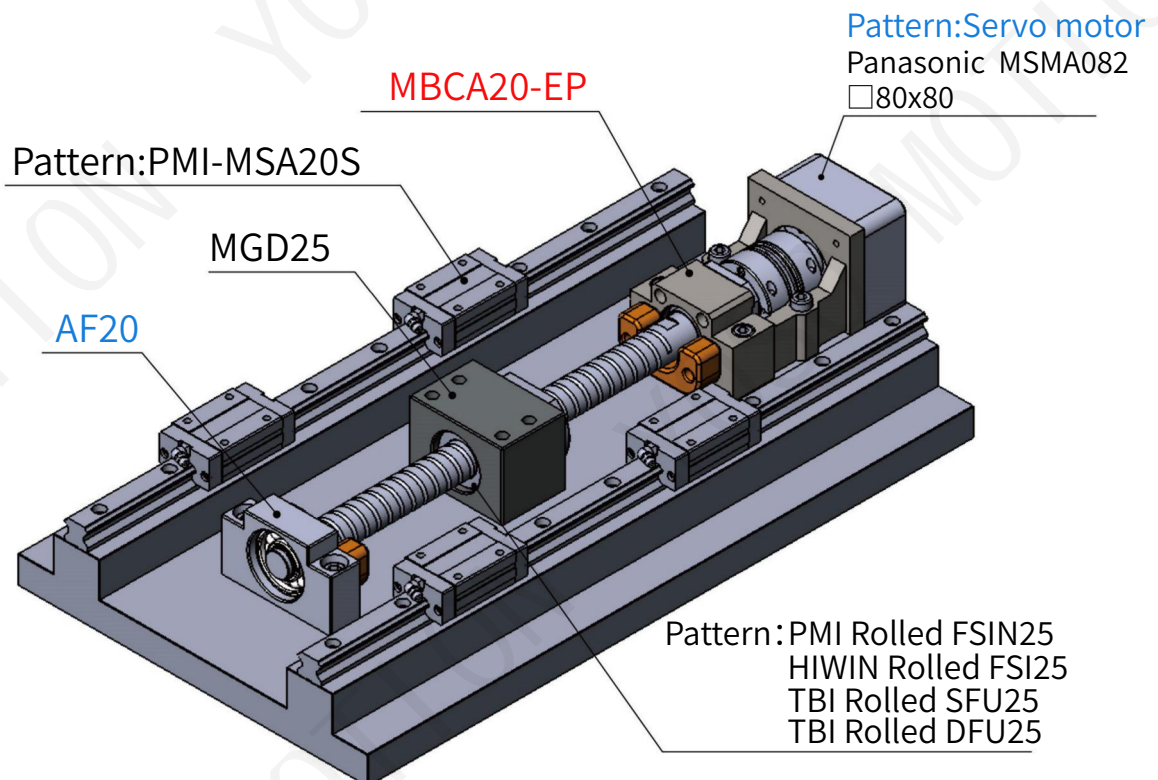

Motor Bracket MBCS15~20 /MBCF20

Motor Bracket MBCS15~20 /MBCF20

Fig→Fixed+Fixed

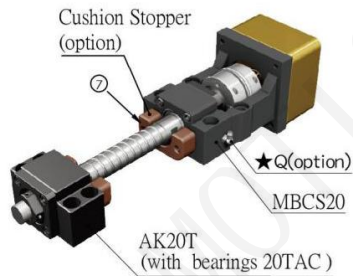

Fig→Fixed+Supported

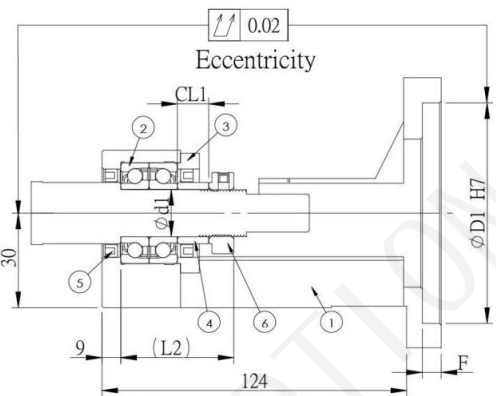
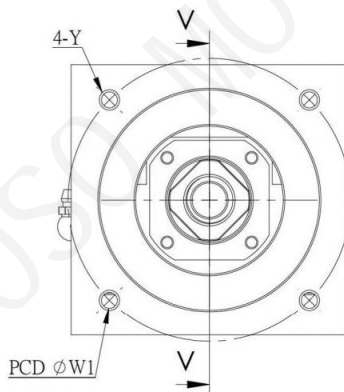
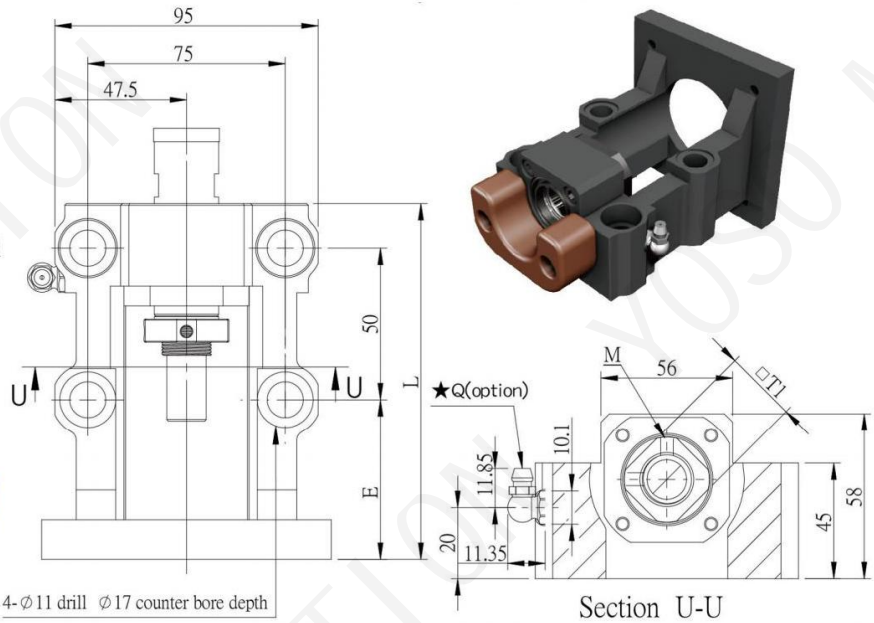
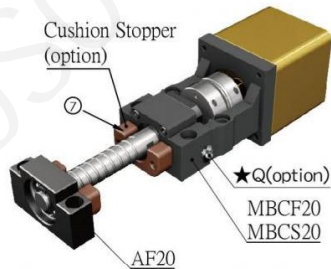

No.	Part name	Qty
1	Housing	1
2	Bearing MBCS15 with bearings 15TAC MBCS17 with bearings 17TAC MBCF20 with bearings 7204 MBCS20 with bearings 20TAC	1set
3	Holding lid	1
4	Collar	2
5	Seal	2
6	Lock nut	1set
7	Cushion Stopper (option)	1

Unit:mm

Model No	D1	W1	Y	L	Shaft diameter d1	CL1	L2	E	F	M	T1	Q	Weight (Kgs)	Support unit	Suggest Coupling
MBCS15-X	80	100	M6	140	15	9	47	70	8	2-M4	22	-		AF 15 EF 15	SGS 50C
MBCS15-Y	95	115	M8	141				71							SGS 50C SGS 57C
MBCS15-YF			M6	141				71							SGS 57C
MBCS15-S	110	130	M8	151				81							SGS 57C
MBCS15-G	110	145	M8	153	83	10	M6	SGS 57C							
MBCS17-X	80	100	M6	140	17	9	57	70	8	4-M6	φ36	-			SGS 50C
MBCS17-Y	95	115	M8	141				71							SGS 50C SGS 57C
MBCS17-YF			M6	141				71							SGS 57C
MBCS17-S	110	130	M8	151				81							SGS 57C
MBCS17-G	110	145	M8	153	83	10	M6	SGS 57C							
MBCF20-X	80	100	M6	140	20	11	50	70	8	2-M4	130	-	EF 20 AF 20	2.76	SGS 50C
MBCF20-Y	95	115	M8	141				71						2.71	SGS 50C SGS 57C
MBCF20-YF			M6	141				71						2.73	SGS 57C
MBCF20-S	110	130	M8	151				81						3.6	SGS 57C
MBCF20-G	110	145	M8	153	83	10	M6	3.77	SGS 57C						
MBCS20-X	80	100	M6	140	20	9	57	70	8	4-M6	φ40	-	AK20T AF20 EF20	2.81	SGS 50C
MBCS20-Y	95	115	M8	141				71						2.85	SGS 50C SGS 57C
MBCS20-YF			M6	141				71						2.85	SGS 57C
MBCS20-S	110	130	M8	151				81						3.69	SGS 57C
MBCS20-G	110	145	M8	153	83	10	M6	3.92	SGS 57C						

Note:

- 1.The matched bearing in the support unit has already done the preload.
- 2.The matched bearings are assembled in DF way, which is the most suitable for ball screw use.
- 3.The accuracy of TAC bearing is P4 grade and 7204 is P5 grade.
- 4.The standard type is without Q, if required, please advise in advance.

■ Illustration for MBC_20

Fixed+Fixed

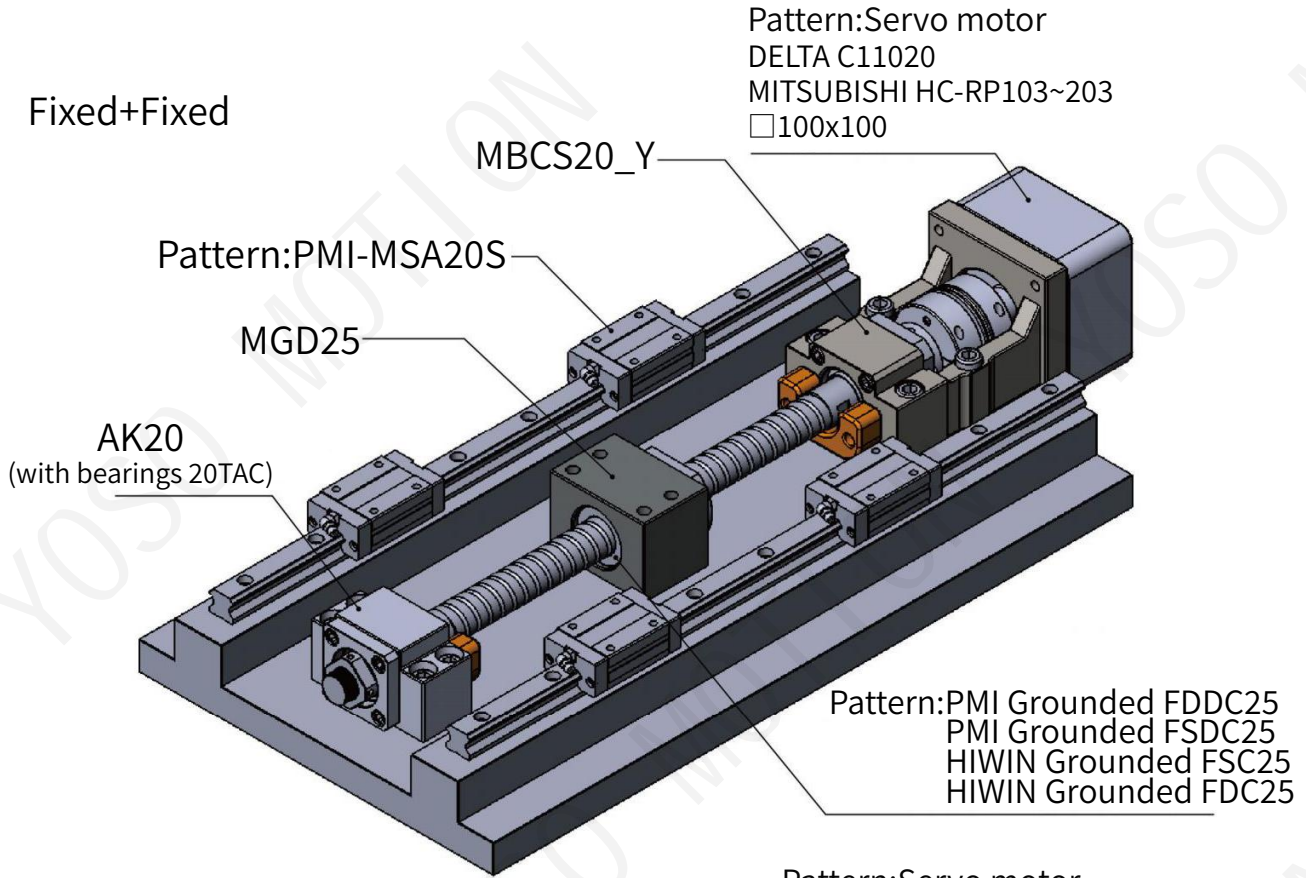

Fixed+Supported

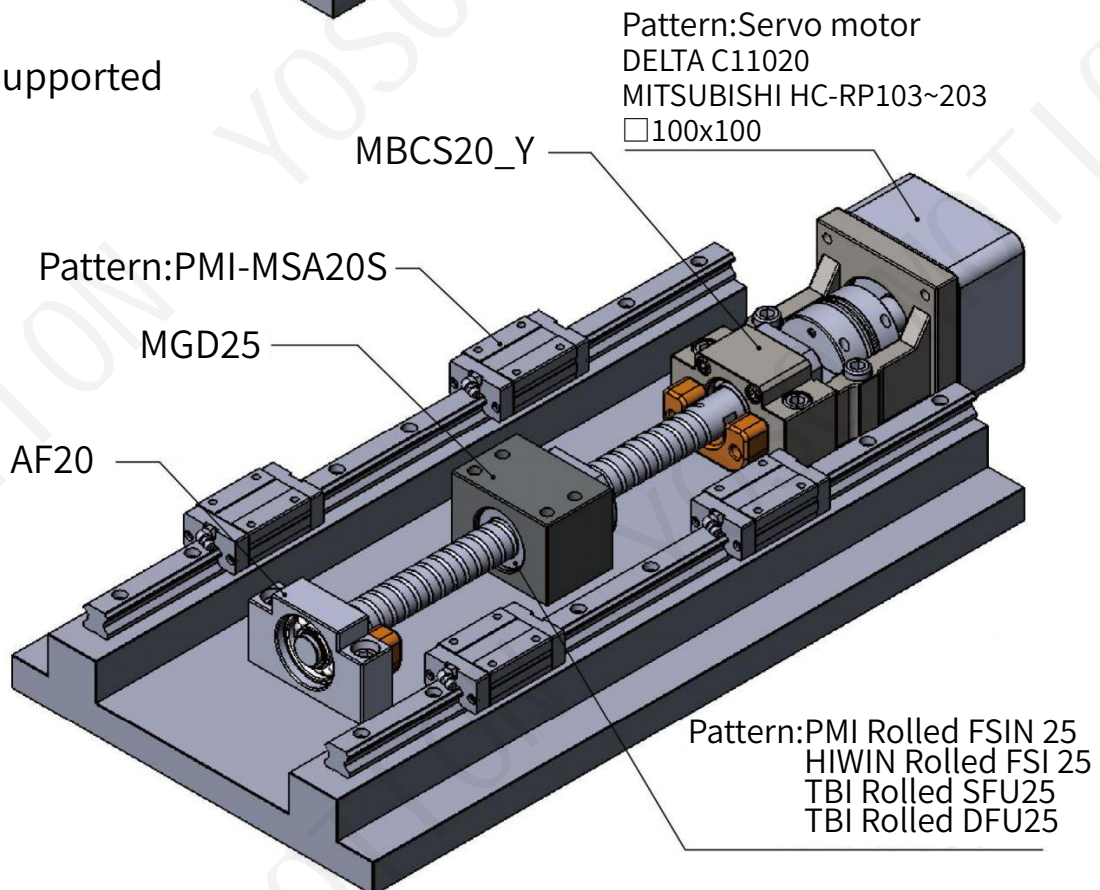

Motor Bracket MBC25

Motor Bracket MBC25

Fig→Fixed+Fixed

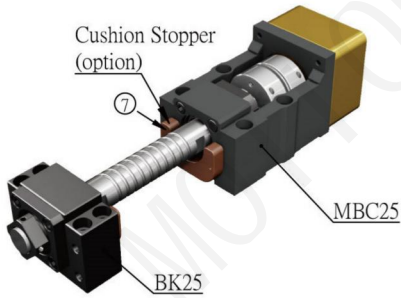

Fig→Fixed+Supported

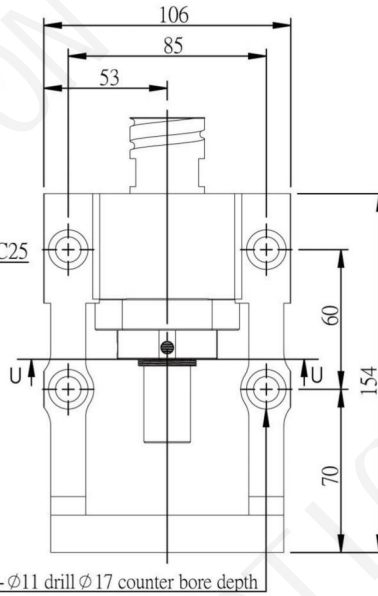
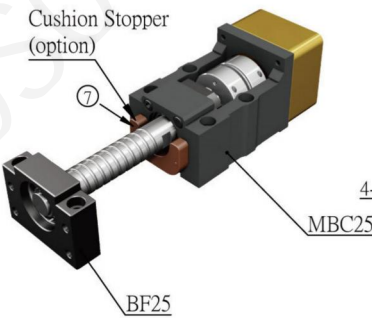

Surface treatment:Black Oxide

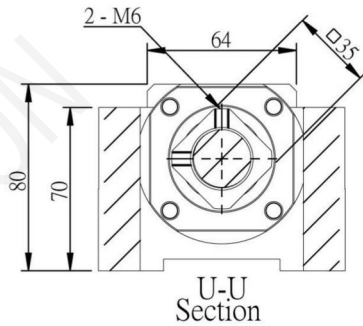

No.	Part name	Qty
1	Housing	1
2	Bearing Bearing 7205	1set
3	Holding lid	1
4	Collar	2
5	Seal	2
6	Lock nut	1set
7	Cushion Stopper (option)	1

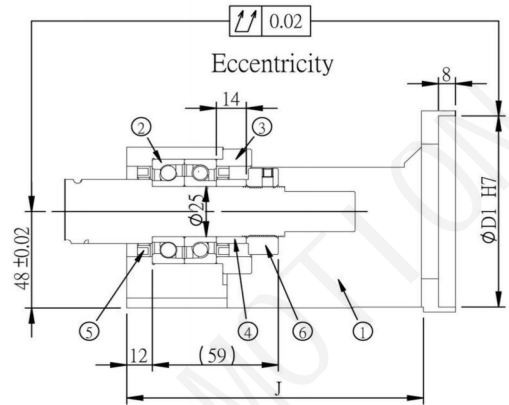
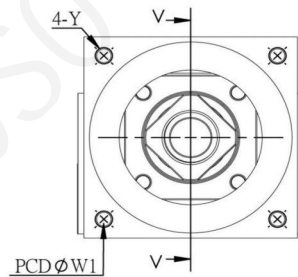

Unit:mm

Model No.	D1	W1	Y	J	Weight (Kgs)	Support unit	Suggest Coupling
						Supported-side	
MBC25-X	80	100	M6	flat		BK25	SGS 57C
MBC25-Y	95	115	M8	139		BF25	SGS 65C
MBC25-YP			M6				

Note :

1.The matched bearing in the support unit has already done the preload.

2.The matched P5 bearings are assembled in DF way,which is the most suitable for ball screw use

■ Illustration for MBC25

Fixed+Fixed

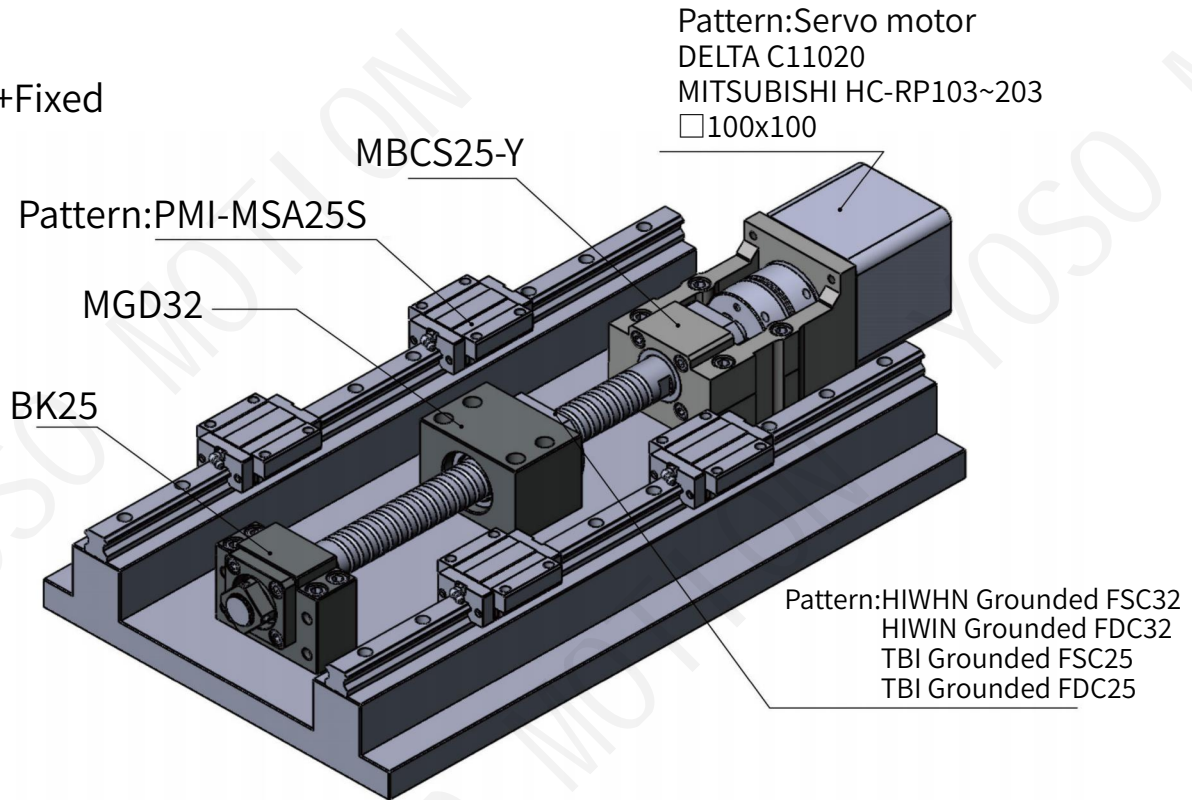

Fixed+Supported

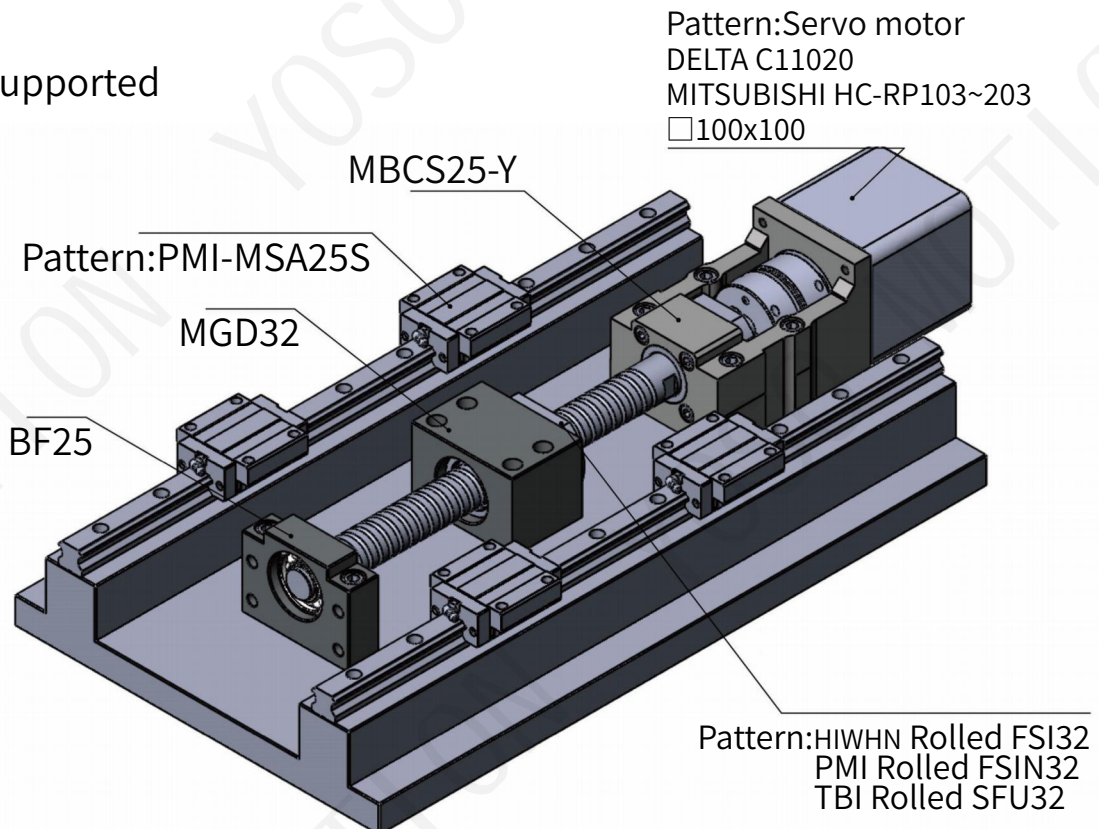

Motor Bracket MBCS25 /MBC30

Motor Bracket MBCS25 /MBC30

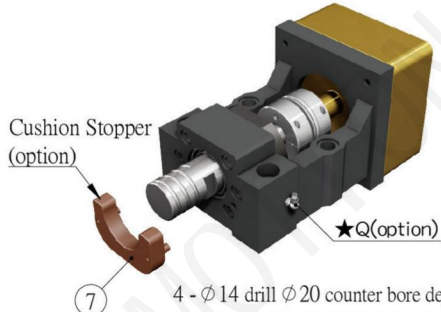

No.	Part name	Qty
1	Housing	1
2	Bearing	1set
	MBCS25 with bearings 25TAC	
	MBCF30 with bearings 7206	
3	MBCS30 with bearings 30TAC	1
	Holding lid	
4	Collar	2
5	Seal	2
6	Lock nut	1set
7	Cushion Stopper (option)	1

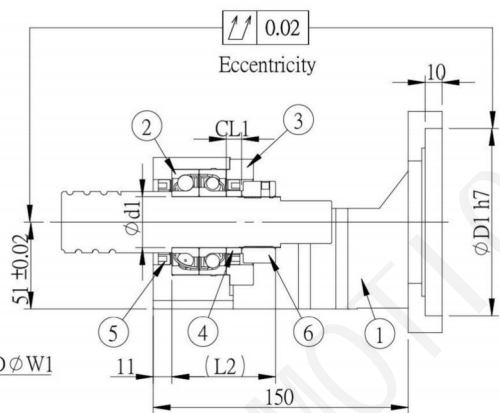
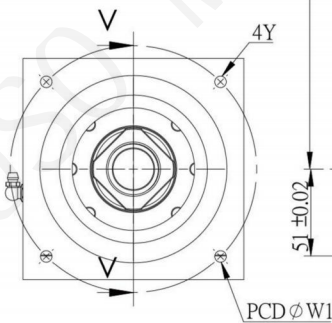
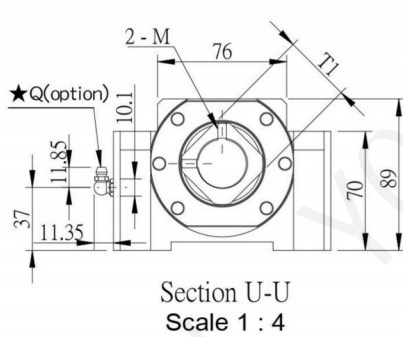
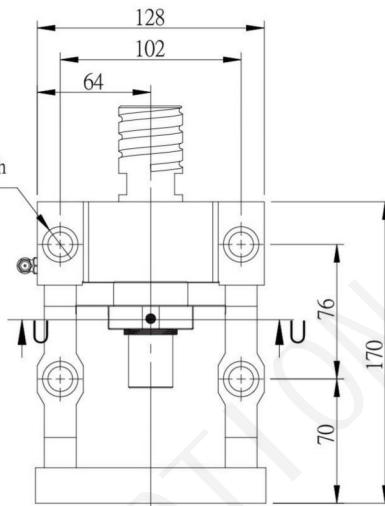

Model No.	D1	W1	Y	Shaft diameter d1	CL1	L2	M	T1	Q	Weight (Kgs)	Support unit	
											Supported-side	Suggest Coupling
MBCS25-Y	95	115	M8	25	15	65	4-M6	$\psi 45$	-	-	SBK25/SF25	SGL 65C
MBCS25-YP			M6									
MBCS25-S		130	M8									
MBCS25-G			145									
MBCF30-Y	95	115	M8	30	9	61	2-M4	40	-	-	BK30/BF30	SGL 65C
MBCF30-YP			M6									
MBCF30-S		130	M8									
MBCF30-G			145									
MBCS30-Y	95	115	M8	30	15	65	4-M6	$\phi 50$	-	-	SBK30	SGL 65C
MBCS30-YP			M6									
MBCS30-S		130	M8									
MBCS30-G			145									

Note:

- 1.The matched bearing in the support unit has already done the preload
- 2.The matched P5 bearings are assembled in DF way,which is the most suitable for ball screw use
- 3.The standard type is without Q;if required,please advise in advance.

■ Illustration for MBC30

Fixed+Fixed

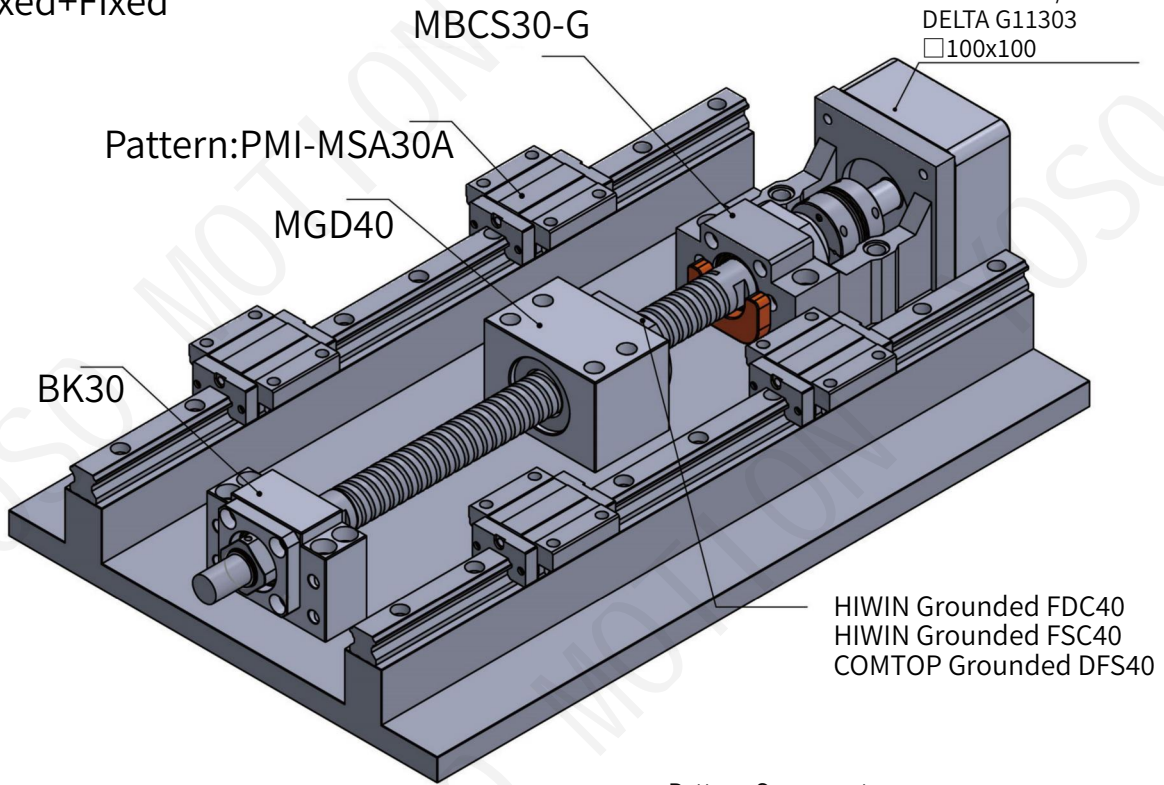

Fixed+Supported

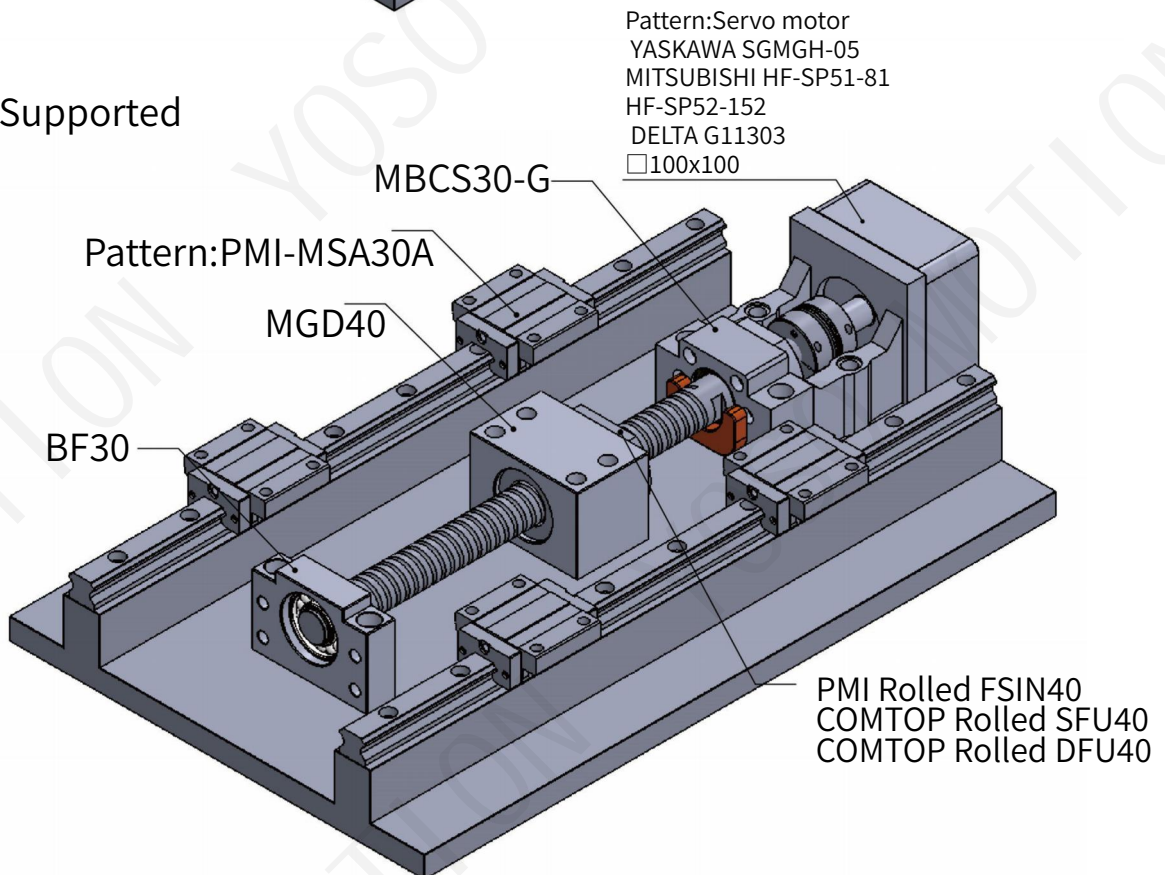

MRecommended shaft end shape(Fixed-side)for MBC types

■ Recommended shaft end shape(Fixed-side)for MBC types

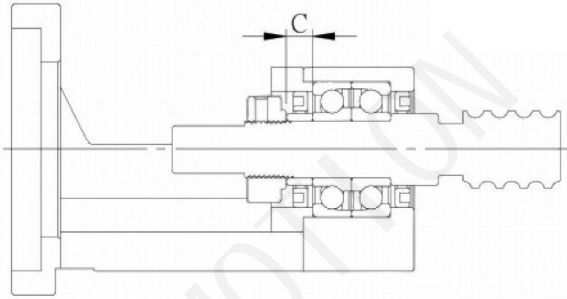

Ground Ballscrew

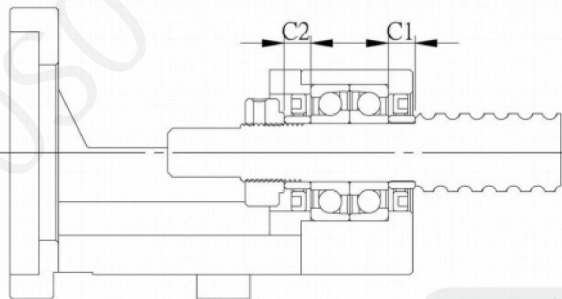
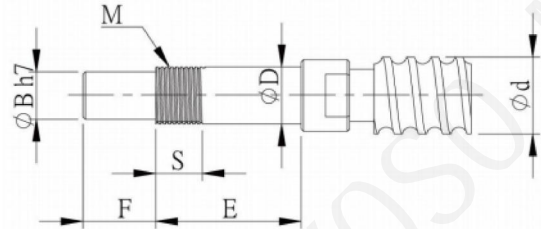

Rolled Ballscrew

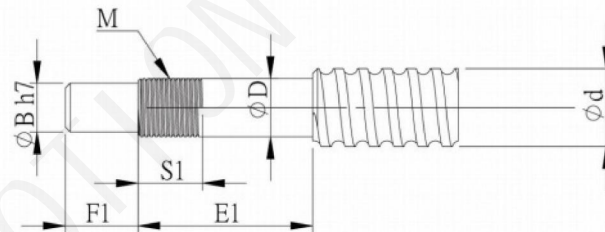

Unit:mm

Model No.	Ballscrew Shaft OD	Shaft support portion OD	Shaft support portion OD					Metric screw thread			Length of Sleeve		
			B	E	E1	F	F1	M	S	S1	C	C1	C2
MBCE10 MBCF10	12/14/15	10 -0.005 -0.017	8	30	36	15		M10X1	10	12	5.5	5.5	
MBCB12	14/15/16	12 -0.005 -0.017	10	30	36	15		M12X1	10	12	5.5	5.5	
MBCE12 MBCF12													
MBCB15	18/20	15 -0.005 -0.017	12	40	40	20		M15X1	15	12	10	6	
MBCB15M												6	10
MBCE15												10	
MBCA15												6	10
MBCS15													
MBCS17	20/25	17 -0.005 -0.017	15	60	69	19		M17X1		16		9	
MBCF20	25/28	20 -0.006 -0.017	17	53	64	27		M20X1		16		11	
MBCS20				60	69	25			23	9			
MBCA20				43	51	22			16	8			
MBC25	30/32/36	25 -0.005 -0.017	20	62	76	33	30	M25X1.5		20		14	
MBCS25				67	82	27			26	15			
MBCF30	36/40	30 -0.010 -0.020	25	64	73	30		M30X1.5		25		9	
MBCS30				67	82	27			26	15			

Motor Bracket MBA(Narrow Type)

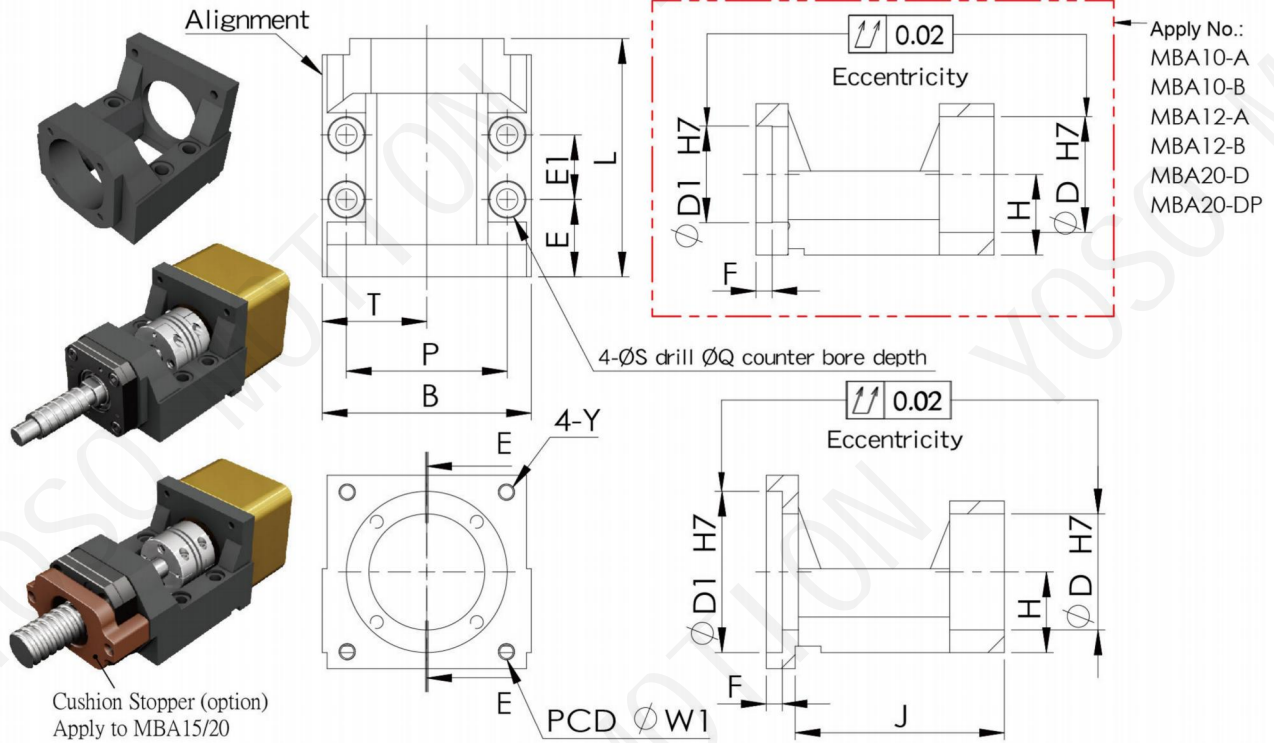

Model No.	Dimensions of Motor Bracket														Support unit		Suggest			
	D1	W1	Y	D	L	H ±0.02	B	P	T	S	Q	E	E1	F	J	Weight (Kgs)	Fixed-side	Supported-side	Coupling	
MBA6/8-A	30	45	M3	28	61	17	52	41	26	5.5	9.5	19	20	5	54	0.29	FKA06 FKA08	EF08	SGS27C	
MBA6/8-B		46	M4																	
MBA10-A	30	45	M3	34	74	22	65	50	32.5	6.6	11	24	20	5	flat	0.62	FK10	BF10	SGL27C	
MBA10-B			46																M4	SGL34C
MBA10-C	38.1	66.7	M5	50	70	70	70	55	35	6.6	11	24	20	5	65	0.66	FK10	BF10	SGL34C	
MBA10-D																			M4	0.62
MBA10-DP	50	70	M4	36	74	25	65	50	32.5	6.6	11	24	20	5	flat	0.67	FK12	BF12	SGL27C	
MBA12-A	30	45	M3																	
MBA12-B		46	M4	36	74	25	65	50	32.5	6.6	11	24	20	5	Thru hole	0.7	FK12	BF12	SGL34C	
MBA12-BE	36	70.7																	M5	0.66
MBA12-C	38.1	66.7	M5	50	70	70	55	35	6.6	11	24	20	5	65	0.68	FK12	BF12	SGL34C		
MBA12-D																		M4	0.66	SGS34C
MBA12-DP	50	70	M4	38.1	66.7	M4	57	113	34	88	70	44	8.5	14	29	42	0.85	FK15	BF15	SGL34C
MBA15-C			M5																	0.86
MBA15-D	50	70	M4	40	84	28	70	55	35	6.6	11	25	28	5	74	0.85	FK15	BF15	SGL34C	
MBA15-DP			M5																0.86	SGS34C
MBA15-F	73	98.4	M6	88	70	44	8.5	14	29	42	6	81	1.3	FK15	BF15	1.37	FK15	BF15	SGS40C	
MBA15-E																			M5	1.31
MBA15-EP	70	90	M5	57	113	34	88	70	44	8.5	14	29	42	6	102	1.56	FK15	BF15	SGS45C	
MBA15-E			M4																1.54	SGS45C
MBA20-D	50	70	M6	57	113	34	88	70	44	8.5	14	29	42	6	102	1.59	FK20	BF20	SGL45C	
MBA20-DP																			M5	1.61
MBA20-F	73	98.4	M5	57	113	34	88	70	44	8.5	14	29	42	6	102	1.62	FK20	BF20	SGL45C	
MBA20-E																			M4	1.62
MBA20-EP	70	90	M5	80	100	M6	88	70	44	8.5	14	29	42	6	102	1.62	FK20	BF20	SGS45C	
MBA20-EP			M6																SGS50C	
MBA20-X	80	100	M6																SGS45C SGS50C	



Note:1.Can choose B angle bearings when use support unit with FKA20

Motor Bracket MBB(Hidden Type)

Motor Bracket MBB(Hidden Type)

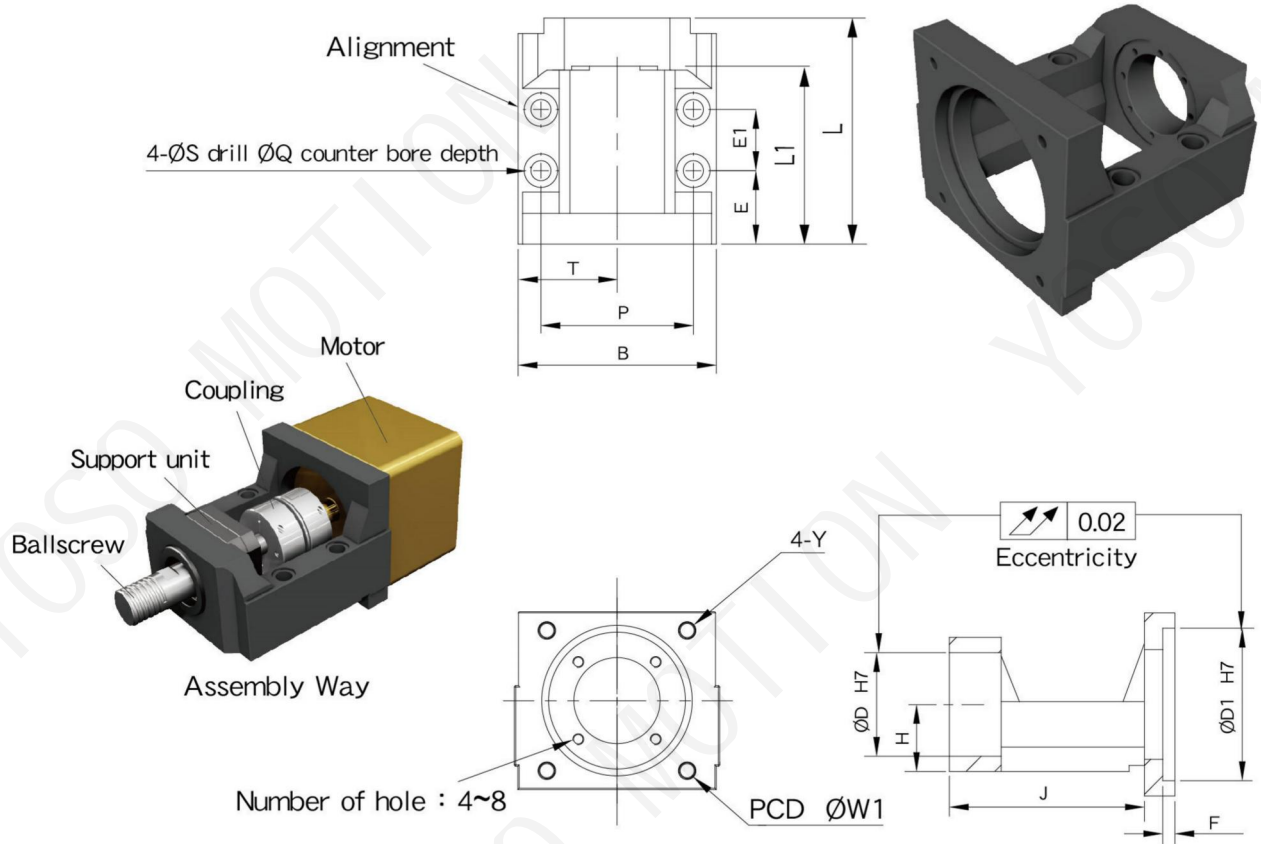

Unit:mm

Model No	Dimensions of Motor Bracket															Support unit		Suggest Coupling		
	D1	W1	Y	D	L	L1	H ±0.02	B	P	T	S	Q	E	E1	F	J	Weight (Kgs)		Fixed-side	Supported-side
MBB20L-G	110	145	M8	57	170	143	48	150	126	75	14	20	53	59	10	151	6.46	FK20B	BF20H	SGL 65C
MBB20-G				58														MBK15DF	BE15+20mm	
																		MBK17DF	BF17+9mm	
MBB25L-S	110	145	M8	63	168	141	48	150	126	75	14	20	51	59	8	146	6.23	FK25	BF25	SGL 65C
MBB25L-G													53		10	151				
MBB25L-G-M													55	70						
MBB30-H	114.3	200	M12	85	230	189	51	200	170	100	18	26	75	75	Third hole	201	14	WBK25DF WBK25DFD	SF25 SBK25	SAP-82C SAP-94C
MBB30-1	130	165	M10	85	230	189	51	200	170	100	18	26	75	75	10	201	14	WBK25DF WBK25DFD	SF25 SBK25	SAP-82C SAP-94C
MBB30-J	150	185																WBK30DF WBK30DFD	BF30 SBK30	

Note:

1.Can choose Bangle bearings when use support unit with FK20/FK25

Motor Bracket MBL(Low Narrow Type)

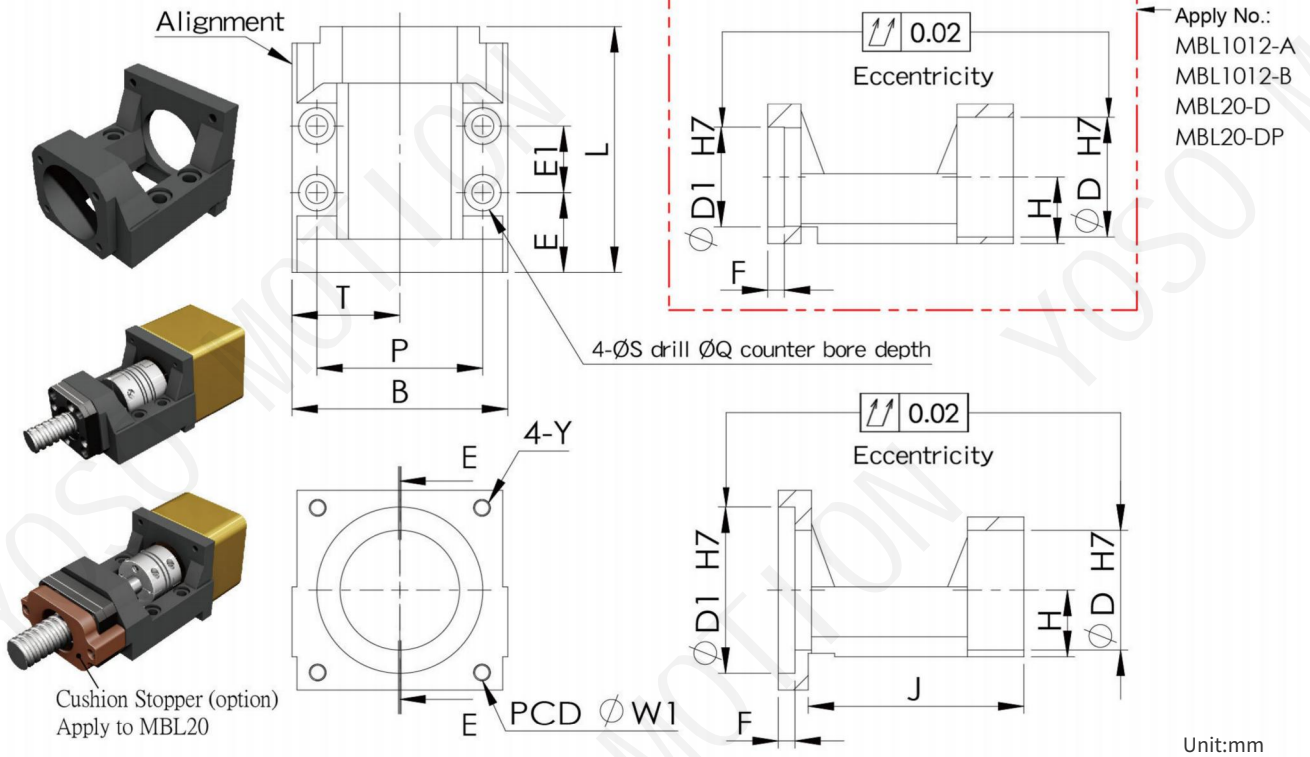

Unit:mm

Model No.	Dimensions of Motor Bracket															Support unit		Suggest Coupling	
	D1	W1	Y	D	L	H ±0.02	B	P	T	S	Q	E	E1	F	J	Weight (Kgs)	Fixed-side		Supported-side
MBL6/8-A	30	45	M3	28	61	15.5	52	41	26	5.5	9.5	19	20	5	54	0.27	FKA06 FKA08	LF08 LFA12	SGS27C
MBL6/8-B		46	M4																
MBL10/12-A	30	45	M3	36	74	20	65	50	32.5	6.6	11	24	20	5	flat	0.56	FKA10 FKA12	LF12 LFA15	SGL27C
MBL10/12-B		46	M4																
MBL10/12-C	38.1	66.7	M4	40	92	22	88	70	44	8.5	14	29	28	6	65	0.61	FKA15	LF15 LFA20	SGL34C
MBL10/12-D	50	70	M5																
MBL10/12-DP			50	70	M4	40	92	22	88	70	44	8.5	14	29	28	6	65	0.57	FKA15
MBL15-C	38.1	66.7			M4														
MBL15-D	50	70	M5	40	84	22	88	70	44	8.5	14	29	28	6	65	0.74	FKA15	LF15 LFA20	SGS34C
MBL15-DP			M4																
MBL15-F	73	98.4	M6	40	92	22	88	70	44	8.5	14	29	28	6	65	0.75	FKA15	LF15 LFA20	SGS40C
MBL15-E	70	90																	
MBL15-EP			70	90	M5	40	92	22	88	70	44	8.5	14	29	28	6	65	0.75	FKA15
MBL20-D	50	70			M5														
MBL20-DP	50	70	M4	40	84	22	88	70	44	8.5	14	29	28	6	65	0.74	FKA15	LF15 LFA20	SGS34C
MBL20-F			73																
MBL20-E	70	90	M5	40	92	22	88	70	44	8.5	14	29	28	6	65	0.75	FKA15	LF15 LFA20	SGS40C
MBL20-EP																			
MBL20-X	80	100	M6	40	92	22	88	70	44	8.5	14	29	28	6	65	0.75	FKA15	LF15 LFA20	SGS40C
MBL20-D	50	70	M5																
MBL20-DP	50	70	M4	40	84	22	88	70	44	8.5	14	29	28	6	65	0.75	FKA15	LF15 LFA20	SGS40C
MBL20-F																			
MBL20-E	70	90	M5	40	92	22	88	70	44	8.5	14	29	28	6	65	0.75	FKA15	LF15 LFA20	SGS40C
MBL20-EP																			
MBL20-D	50	70	M4	40	84	22	88	70	44	8.5	14	29	28	6	65	0.75	FKA15	LF15 LFA20	SGS40C
MBL20-DP																			
MBL20-F	70	90	M5	40	92	22	88	70	44	8.5	14	29	28	6	65	0.75	FKA15	LF15 LFA20	SGS40C
MBL20-E																			
MBL20-EP	70	90	M5	40	92	22	88	70	44	8.5	14	29	28	6	65	0.75	FKA15	LF15 LFA20	SGS40C
MBL20-D																			
MBL20-DP	50	70	M4	40	84	22	88	70	44	8.5	14	29	28	6	65	0.75	FKA15	LF15 LFA20	SGS40C
MBL20-F																			
MBL20-E	70	90	M5	40	92	22	88	70	44	8.5	14	29	28	6	65	0.75	FKA15	LF15 LFA20	SGS40C
MBL20-EP																			
MBL20-D	50	70	M4	40	84	22	88	70	44	8.5	14	29	28	6	65	0.75	FKA15	LF15 LFA20	SGS40C
MBL20-DP																			
MBL20-F	70	90	M5	40	92	22	88	70	44	8.5	14	29	28	6	65	0.75	FKA15	LF15 LFA20	SGS40C
MBL20-E																			
MBL20-EP	70	90	M5	40	92	22	88	70	44	8.5	14	29	28	6	65	0.75	FKA15	LF15 LFA20	SGS40C
MBL20-D																			
MBL20-DP	50	70	M4	40	84	22	88	70	44	8.5	14	29	28	6	65	0.75	FKA15	LF15 LFA20	SGS40C
MBL20-F																			
MBL20-E	70	90	M5	40	92	22	88	70	44	8.5	14	29	28	6	65	0.75	FKA15	LF15 LFA20	SGS40C
MBL20-EP																			
MBL20-D	50	70	M4	40	84	22	88	70	44	8.5	14	29	28	6	65	0.75	FKA15	LF15 LFA20	SGS40C
MBL20-DP																			
MBL20-F	70	90	M5	40	92	22	88	70	44	8.5	14	29	28	6	65	0.75	FKA15	LF15 LFA20	SGS40C
MBL20-E																			
MBL20-EP	70	90	M5	40	92	22	88	70	44	8.5	14	29	28	6	65	0.75	FKA15	LF15 LFA20	SGS40C
MBL20-D																			
MBL20-DP	50	70	M4	40	84	22	88	70	44	8.5	14	29	28	6	65	0.75	FKA15	LF15 LFA20	SGS40C
MBL20-F																			
MBL20-E	70	90	M5	40	92	22	88	70	44	8.5	14	29	28	6	65	0.75	FKA15	LF15 LFA20	SGS40C
MBL20-EP																			
MBL20-D	50	70	M4	40	84	22	88	70	44	8.5	14	29	28	6	65	0.75	FKA15	LF15 LFA20	SGS40C
MBL20-DP																			
MBL20-F	70	90	M5	40	92	22	88	70	44	8.5	14	29	28	6	65	0.75	FKA15	LF15 LFA20	SGS40C
MBL20-E																			
MBL20-EP	70	90	M5	40	92	22	88	70	44	8.5	14	29	28	6	65	0.75	FKA15	LF15 LFA20	SGS40C
MBL20-D																			
MBL20-DP	50	70	M4	40	84	22	88	70	44	8.5	14	29	28	6	65	0.75	FKA15	LF15 LFA20	SGS40C
MBL20-F																			
MBL20-E	70	90	M5	40	92	22	88	70	44	8.5	14	29	28	6	65	0.75	FKA15	LF15 LFA20	SGS40C
MBL20-EP																			
MBL20-D	50	70	M4	40	84	22	88	70	44	8.5	14	29	28	6	65	0.75	FKA15	LF15 LFA20	SGS40C
MBL20-DP																			
MBL20-F	70	90	M5	40	92	22	88	70	44	8.5	14	29	28	6	65	0.75	FKA15	LF15 LFA20	SGS40C
MBL20-E																			
MBL20-EP	70	90	M5	40	92	22	88	70	44	8.5	14	29	28	6	65	0.75	FKA15	LF15 LFA20	SGS40C
MBL20-D																			
MBL20-DP	50	70	M4	40	84	22	88	70	44	8.5	14	29	28	6	65	0.75	FKA15	LF15 LFA20	SGS40C
MBL20-F																			
MBL20-E	70	90	M5	40	92	22	88	70	44	8.5	14	29	28	6	65	0.75	FKA15	LF15 LFA20	SGS40C
MBL20-EP																			
MBL20-D	50	70	M4	40	84	22	88	70	44	8.5	14	29	28	6	65	0.75	FKA15	LF15 LFA20	SGS40C
MBL20-DP																			
MBL20-F	70	90	M5	40	92	22	88	70	44	8.5	14	29	28	6	65	0.75	FKA15	LF15 LFA20	SGS40C
MBL20-E																			
MBL20-EP	70	90	M5	40	92	22	88	70	44	8.5	14	29	28	6	65	0.75	FKA15		

Motor Bracket MBH

Motor Bracket MBH

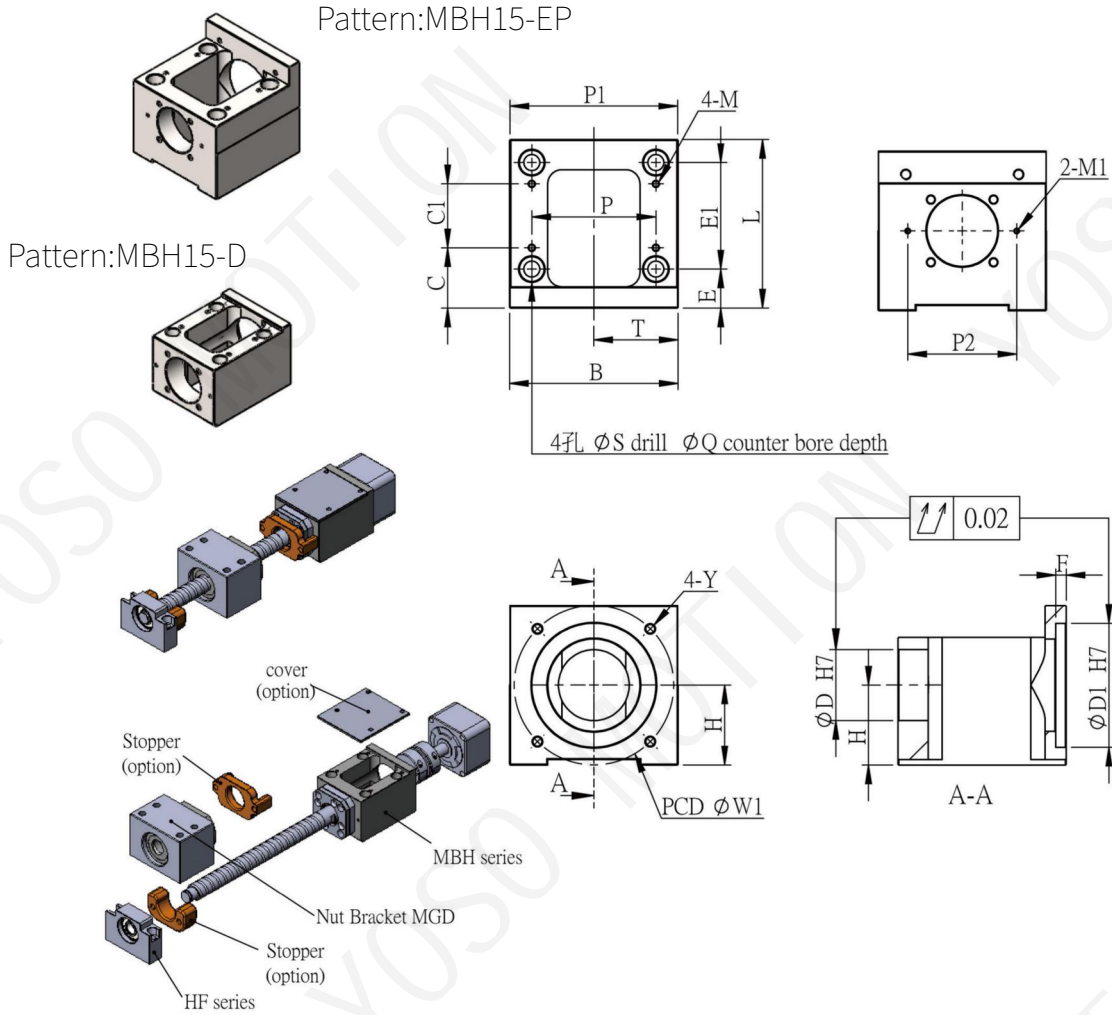

Unit:mm

Model No.	D1	W1	Y	L	D	H ±0.02	B	T	P	S	Q	E
MBH15-D	50	70	M5	88	40	30	70	35	54	6.6	11	23
MBH15-DP			M4									
MBH15-E	70	90	M6	95	40	45	95	47.5	70	9	14	22
MBH15-EP			M5									
※ MBH15H-EP			M5		50							

Model No.	E1	P1	M	C	C1	M1	P2	F	Weight (Kgs)	Support unit		Suggest Coupling
										Fixed-side	Supported-side	
MBH15-D	50		M4	33	30	M3	61.5	5	—	FK 15	HF15	SGS34C SGS40C
MBH15-DP			1.09									
MBH15-E	60	94.6	M4	34	36	M3	61.5	6	—	FK 15	HF15	SGS45C SGS50C
MBH15-EP												
※ MBH15H-EP												—

※Under developmen

■ Support Unit HF

Pattern:HF15H

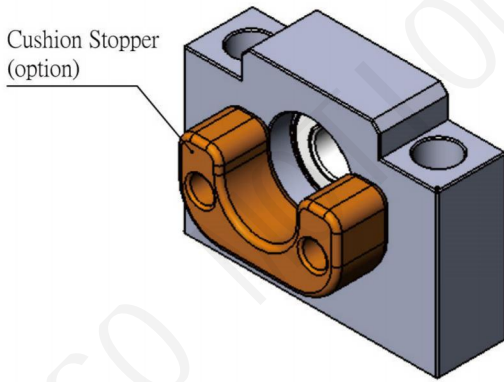

No.	Part name	Qty
1	Housing	1
2	Bearing	1 set
3	Snap ring	1
4	Cushion Stopper (option)	1

HF

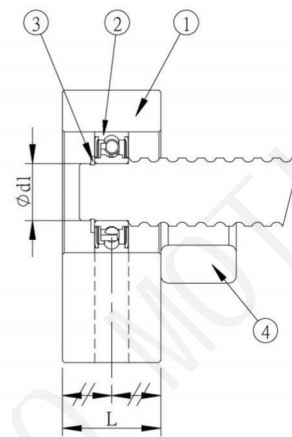
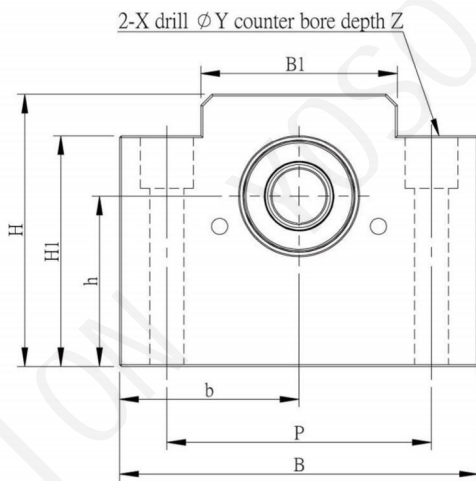

Unit:mm

Model No.	Shaft diameter	L	B	H	b	h	B1	H1	P	X	Y	Z	Bearing	Snap ring	Weight (Kgs)
					±0.02	±0.02									
HF15	15	20	70	50	35	30	41	40	60	6.6	12	10	6002ZZ	S 15	0.34
HF15H	15	26	95	72	47.5	45	52	61	70	9	14	14	6002ZZ	S 15	-

Motor Bracket MB and Corresponding motor reference table

■ Motor Bracket MB and Corresponding motor reference table

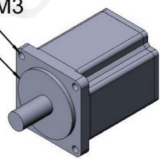
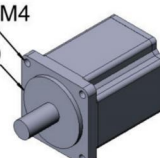
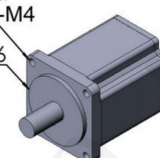
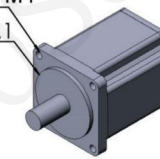
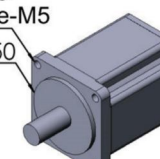
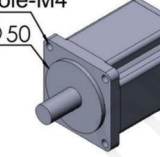
Motor Bracket	Servo Motor Brand Specification		
	Manufacturer	Model No.	Flange Width
MB*-A PCD ϕ 45 Fixed hole-M3 Flange O.D ϕ 30 	Panasonic	MSMA3A MSMA5A MAMA01	38
	HIWIN	FRLS50W/100W	
MB*-B PCD ϕ 46 Fixed hole-M4 Flange O.D ϕ 30 	Yaskawa electric	SGMAH-A3 SGMAH-A5	40
	Mitsubishi electric	HF-KP053/13 HF-MP053/13	
	OMRON	R88M-W03030 R88M-W05030 R88M-W10030	
	SANYO	P30B04003 P30B04005 P30B04010	
MB*-BF PCD ϕ 70.7 Fixed hole-M4 Flange O.D ϕ 36 	Oriental motor	ARM69AC	60
MB*-C PCD ϕ 66.7 Fixed hole-M4 Flange O.D ϕ 38.1 	Yaskawa electric	02SGMAH-21 04SGMAH-21	60
MB*-D PCD ϕ 70 Fixed hole-M5 Flange O.D ϕ 50 	Yaskawa electric	SGMAH-02/04A SGMAH-03D	60
	Mitsubishi electric	HF-KP23/43 HF-MP23/43	
	OMRON	R88M-W20030 R88M-W40030	
	SANYO	P30B06020 P30B06040	
	DELTA	C10602 C10604	
	HIWIN	FRLS200W FRLS400W	
MB*-DP PCD ϕ 70 Fixed hole-M4 Flange O.D ϕ 50 	Panasonic	MSMA021 MSMA041	60

Note:

1. Please notice the length of motor shaft.

2. Specifications are subject to change without prior notice if required to improve performance.

Motor Bracket MB and Corresponding motor reference table

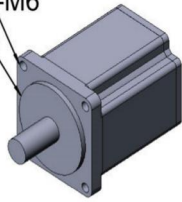
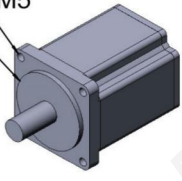
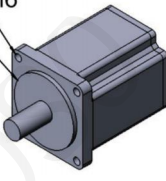
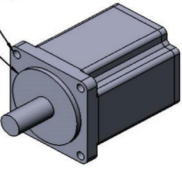
Motor Bracket	Servo Motor Brand Specification		
	Manufacturer	Model No.	Flange Width
MB*-E PCD ϕ 90 Fixed hole-M6 Flange O.D ϕ 70 	Yaskawa electric	SGMAH-08A	80
	Mitsubishi electric	HF-KP73 HF-MP73	
	SANYO	P30B08075	
	DELTA	C10807	
	HIWIN	FRMS750W	
MB*-EP PCD ϕ 90 Fixed hole-M5 Flange O.D ϕ 70 	Panasonic	MSMA082	80
MB*-F PCD ϕ 98.4 Fixed hole-M6 Flange O.D ϕ 73 	Yaskawa electric	SGMAH-N21	85
MB*-G PCD ϕ 145 Fixed hole-M8 Flange O.D ϕ 110 	Yaskawa electric	SGMGH-05 SGMGH-09 SGMGH-13	120-130
	Mitsubishi electric	HF-SP51-81 HF-SP52-152 HF-SP524-1524 HC-LP52-152	
	DELTA	E11305, G11303 E11310, G11306 E11315, G11309 E11320	
	Panasonic	MDMA102 MDMA152 MDMA202 MDMA252 MDMA302	130
	FANUC	B8, B12	
	HIWIN	FRMMIKW	

Note:

1. Please notice the length of motor shaft.
2. Specifications are subject to change without prior notice if required to improve performance.

Motor Bracket MB and Corresponding motor reference table

Motor Bracket MB and Corresponding motor reference table

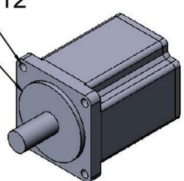
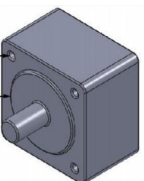
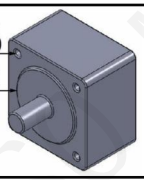
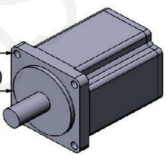
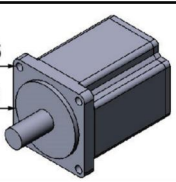
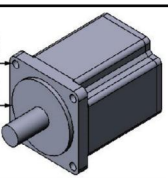
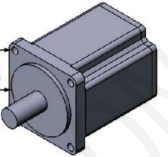
Motor Bracket	Servo Motor Brand Specification		
	Manufacturer	Model No.	Flange Width
MB*-H PCD ϕ 200 Fixed hole-M12 Flange O.D ϕ 114.3 	Yaskawa electric	SGMGH-20 SGMGH-30 SGNGH-44	180
	DELTA	E11820 E11830 F11830	
	Mitsubishi electric	HF-SP121-421 HF-SP202-702 HF-SP2024 HF-SP5024 HF-SP7024 HC-LP202 HC-LP302	176
	Panasonic	MDMA452 MDMA502	
MB*-I PCD ϕ 165 Fixed hole-M10 Flange O.D ϕ 130 	SIEMENS	1FT708 1FK708	155
	HEIDENHAIN	QSY155	
MB*-J PCD ϕ 185 Fixed hole-M10 Flange O.D ϕ 150 	SYBTEC	SP-L5.5-12 SP-L5.5-18 SP-L11-18 SP-M5.5-12	178
MB*-S PCD ϕ 130 Fixed hole-M8 Flange O.D ϕ 110 	SIEMENS	1FK7060 1FT6062	126 116
MB*-X PCD ϕ 100 Fixed hole-M6 Flange O.D ϕ 80 	FANUS	β 2/4000is β 4/4000is	90
	SIEMENS	1FT6044 1FK7042-5	96
MB*-Y PCD ϕ 115 Fixed hole-M8 Flange O.D ϕ 95 	DELTA	C11010 C11020	100
	Mitsubishi electric	HC-RP103/153 HC-RP203	
MB*-YP PCD ϕ 115 Fixed hole-M6 Flange O.D ϕ 95 	Yaskawa electric	SGMSH-10 SGMSH-15 SGMSH-20	100

Note:

1.Please notice the length of motor shaft.

2.Specifications are subject to change without prior notice if required to improve performance.

Characteristic Values of (Fixed-side) Support Units and Bearing

Applicable Ballscrew OD	Fixed-side					Supported-side						
	Basic dynamic load rating Ca (N)	Load limit (N)	Stiffness (N/μm)	Bearing code	Applicable model	Applicable model	Bearing code	Radial direction Basic dynamic load rating C _r (N)				
68	2670	1040	32.8	706 A	FK06 EK06	FF06 EF06	606 ZZ	2260				
\$ 10~\$12	4400	1450	48.9	708 A	FK08 EK08 LK08	FF06 EF08 LF08 LFA12	606 ZZ 6801 ZZ	2260 1920				
\$ 10~\$15	6600	2730	94	7000 A	BK10 FK10 LK10 AK10 EK10	BF10 FF10 EF10 AF10 LF12 LFA15	608ZZ 6000 ZZ 6902 ZZ	3300 4550 4350				
614~\$18	7100	3040	104	7001 A	BK12 FK12 LK12 EK12 AK12 MBC*12	BF12 FF12 LF12 EF12 AF12 LFA15	6000 ZZ 6902 ZZ	4550 4350				
\$ 20	7600	3380	113	7002 A	BK15 FK15 LK15 EK15 AK15 MBC*15	BF15 FF15 LF15 EF15 AF15 LFA20	6002 ZZ 6804 ZZ	5600 4000				
625~628	17200	6900	120	7302 A	MBCA15	AF15	6002 ZZ	5600				
\$ 30~\$36	12000	5800	139	7203 A	BK17 FK17	BF17 FF17	6203 ZZ	9550				
\$ 30~\$36	12700	6400	155	7004 A	BK20	BF20	6004 ZZ	9400				
\$ 30~\$36	17900	8240	193	7204 A	AK20 FK20 EK20 MBCF20	EF20 AF20 FF20	6204 ZZ	12800				
\$ 30~\$36	20000	7400	210	7204 B	AK20B FK20B EK20B BK25 FK25 AK25 MBC25	LFA25 (with AK20)	6005 ZZ	10100				
940	20200	10000	193	7205 A	BK25 FK25 AK25 MBC25	BF25 FF25 AF25	6205 ZZ	14000				
940	23300	8900	210	7205 B	BK25B FK25B AK25B	BF25 FF25 AF25	6205 ZZ	14000				
\$ 45	28000	13700	210	7206 A	BK30 FK30	BF30 FF30	6206 ZZ	19500				
\$ 45	30700	12500	210	7206 B	BK30B FK30B	BF30 FF30	6206 ZZ	19500				
\$ 45	37200	16500	210	7207 B	BK35	BF35	6207 ZZ	25700				
950	44100	20900	210	7208 B	BK40	BF40	6208 ZZ	29100				

NOTE:

1. IF THE MOUNTING METHOD IS "FIXED SIDE+FIXED SIDE", THE VALUE OF BASIC DYNAMIC LOAD RATE SHOULD BE DOUBLED.

(The value is for reference only. Please refer the catalogue from each bearing company for actual value)

2. ABOVE TABLE IS FOR NSK BEARING.

Characteristic Values of (Heavy-load) Support Units and Bearing

■ Characteristic Values of (Heavy-load) Support Units and Bearing

Applicable Ballscrew OD	Fixed-side							Supported-side			
	Basic dynamic load rating Ca(N)	limiting axial load (N)	preload (N)	axial rigidity (N/μm)	starting torque (N · cm)	permissible rotational speed	Bearing code	Applicable mode	Applicable mode	Bearing code	Radial Basic dynamic load ratingCr (N)
620	21900	26600	1000	555	19	7600	15TAC47C	MBK15DF MBCS15	AF15	6002 ZZ	5600
S 20~ S 25	23000	26600	1450	630	19	6900	17TAC47C	WBK17 DF MBK17 DF MBCS17			
	47500	53500	2010	920	32			MBK17 DFF			
S 25~ S 28	23000	26600	1450	630	19	6900	20TAC47C	WBK20 DF MBCS20 MBK20 DF	EF20 AF20	6204 ZZ	12800
	47500	53500	2010	920	32			MBK20 DFF	FF20		
S 30~ S 36	29900	40500	2280	850	28	5200	25TAC 62	WBK25 DF SBK25 DF MBCS25	FF25 SF25	6205 ZZ	14000
	48500	81500	3100	1250	39			WBK25 DFD SBK25 DFD			
	48500	81500	4500	1680	49			WBK25 DFF			
	30500	43000	2400	890	29			WBK30 DF SBK30 DF MBCS30			
640	50000	86000	3260	1310	39	4900	30TAC 62C	WBK30 DFD SBK30 DFD	BF30 FF30	6206 ZZ	19500
	50000	86000	4750	1760	51			WBK30 DFF			
	32500	50000	2750	1030	33			WBK35 DF SBK35 DF			
S 45	53000	100000	3740	1500	41	4100	35TAC 72C	WBK35 DFD SBK35 DFD	BF35	6207ZZ	25700
	53000	100000	5490	2060	52			WBK35 DFF			
	33500	52000	2860	1080	34			WBK40 DF SBK40 DF			
650	54000	104000	3900	1590	43	4100	40TAC72C	WBK40 DFD SBK40 DFD	SF40	6208 ZZ	29100
	54000	104000	5730	2150	55			WBK40 DFF			

NOTE:

1. IF THE MOUNTING METHOD IS "FIXED SIDE+FIXED SIDE", THE VALUE OF BASIC DYNAMIC LOAD RATE SHOULD BE DOUBLED.

(The value is for reference only. Please refer the catalogue from each bearing company for actual value)

2. ABOVE TABLE IS FOR NSK BEARING.

■ Support Unit Ak (fixed-side rectangular type)

Cushion Stopper
(option)

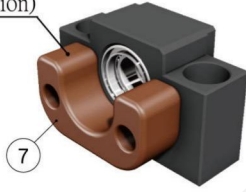

AK10~AK15



AK20

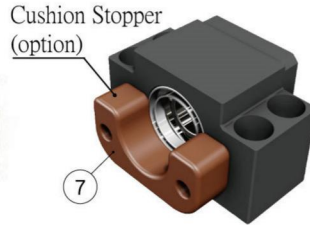

AK25

AK

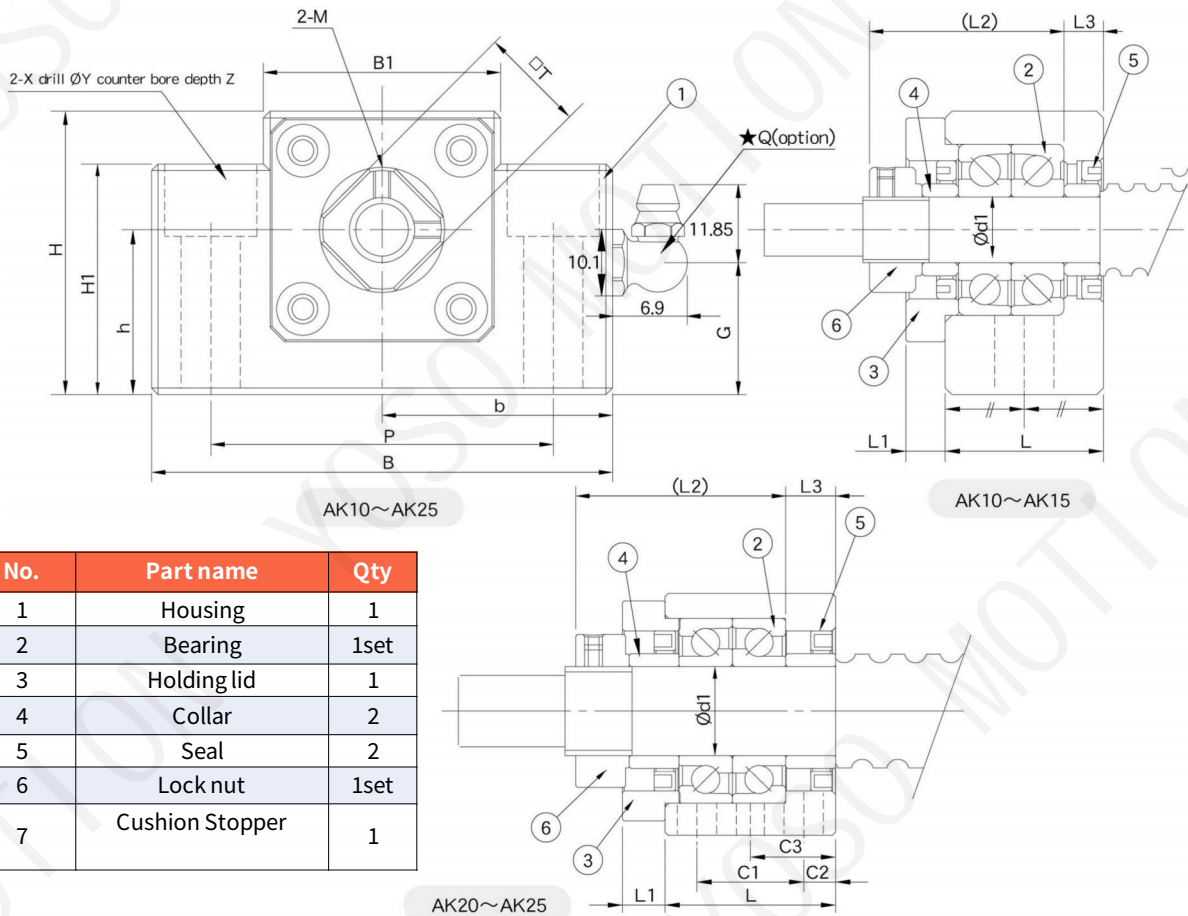

Unit:mm

Model No.	Shaft diameter d1	L	L1	L2	L3	B	H	b ±0.02	h ±0.02	B1	H1	P	X	Y	Z	M	T	C1	C2	C3	G	Q	Weight gS
AK10	10	24	6	29.5	6	70	43	35	25	36	35	52	9	14	11	M3	16	-	-	-	20	M6	0.5
AK12	12	24	6	29.5	6	70	43	35	25	63	35	52	9	14	11	M4	19	-	-	-	20	M6	0.5
AK15	15	25	6	36	5	80	50	40	30	41	40	60	11	17	15	M4	22	-	-	-	21	M6	0.62
AK20	20	42	10	60	10	95	58	47.5	30	56	45	75	11	17	15	M4	30	22	10	-	24	M6	1.43
AK25	25	48	12	59	14	105	68	52.5	35	66	25	85	11	-	-	M5	35	30	9	24	58	-	1.92

Support Unit AK(fixed-side rectangular type)

■ Support Unit AK(fixed-side rectangular type)

Order Codin	Model No.	Surface treatment	Applicable ballscrew accuracy erace	Bearing		Delivery date	 <p>Black Oxide (Application:Generalcase)</p>
				Model No.	Max.Starting torque (gf-cm)		
AK10	AK10	Black Oxide	C3~C10	7000A P5	190	EX-STOCK	 <p>Electroless Nickel Plating (Application:Clean room)</p>
AK10_C5			C5~C10	7000A PO	190	EX-STOCK	
AK10_C3			C3	7000A P5	190	EX-STOCK	
AK10_N		Electroless Nickel Plating	C3~C10	7000A P5	190	3 days	
AK10_C5N			C5~C10	7000A PO	190	3 days	
AK10_C3N			C3	7000A P5	190	3 days	
AK12	AK12	Black Oxide	C3~C10	7001A P5	210	EX-STOCK	 <p>Electroless Nickel Plating (Application:Clean room)</p>
AK12_C5			C5~C10	7001A PO	210	EX-STOCK	
AK12_C3			C3	7001A P5	210	EX-STOCK	
AK12_N		Electroless Nickel Plating	C3~C10	7001A P5	210	EX-STOCK	
AK12_C5N			C5~C10	7001A PO	210	3 days	
AK12_C3N			C3	7001A P5	210	3 days	
AK15	AK15	Black Oxide	C3~C10	7002A P5	230	EX-STOCK	 <p>Black Oxide (Application:General case)</p>
AK15_C5			C5~C10	7002A PO	230	EX-STOCK	
AK15_C3			C3	7002A P5	230	EX-STOCK	
AK15_N		Electroless Nickel Plating	C3~C10	7002A P5	230	EX-STOCK	
AK15_C5N			C5~C10	7002A PO	230	3 days	
AK15_C3N			C3	7002A P5	230	3 days	
AK20	AK20	Black Oxide	C3~C10	7204A P5	550	EX-STOCK	 <p>Electroless Nickel Plating (Application:Cleanroom)</p>
AK20_C5			C5~C10	7204A PO	550	EX-STOCK	
AK20B_C5			C5~C10	7204B P0	550	EX-STOCK	
AK20_C3			C3	7204A P5	550	3 days	
AK20_N		Electroless Nickel Plating	C3~10	7204A P5	550	3 days	
AK20_C5N			C5~C10	7204A PO	550	3 days	
AK20B_C5N			C5~C10	7204B P0	550	3 days	
AK20_C3N			C3	7204A P5	550	3 days	
AK25	AK25	Black Oxide	C3~10	7205A P5	730	EX-STOCK	<p>Black Oxide (Application :General case)</p>
AK25_C5			C5~C10	7205A PO	730	EX-STOCK	
AK25B_C5			C5~C10	7205B P0	730	3 days	
AK25_C3			C3	7205A P5	730	3 days	
AK25_N		Electroless Nickel Plating	C3~10	7205A P5	730	EX-STOCK	
AK25_C5N			C5~C10	7205A PO	730	3 days	
AK25B_C5N			C5~C10	7205B P0	730	3 days	
AK25_C3N			C3	7205A P5	730	3 days	

Note:

- 1.All types make Preload.
- 2.All of bearings use Japanese & Taiwanese brand bearings(Model No.in blue) Assembly by DFway.The most suitable way for ballscrew use
- 3.The standard type is without Q,if required,please advise in advance.

■ Support Unit AF (supported-side rectangular type)

No.	Part name	Qty
1	Housing	1
2	Bearing	1 set
3	Snap ring	1
4	Cushion Stopper	1

Cushion Stopper
(option)

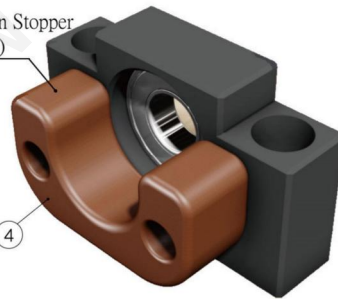

AF10~AF20

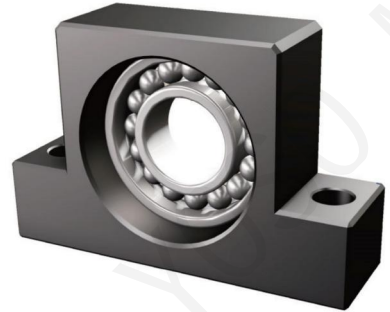

AF25

AF

2X drill $\varnothing Y$ counter bore depth Z

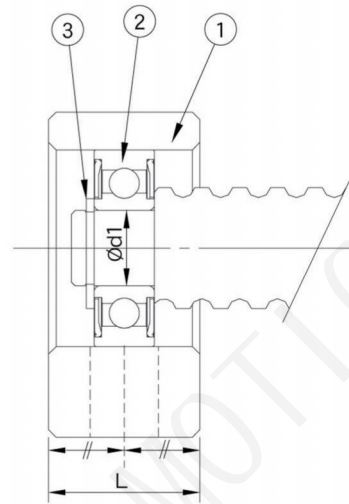
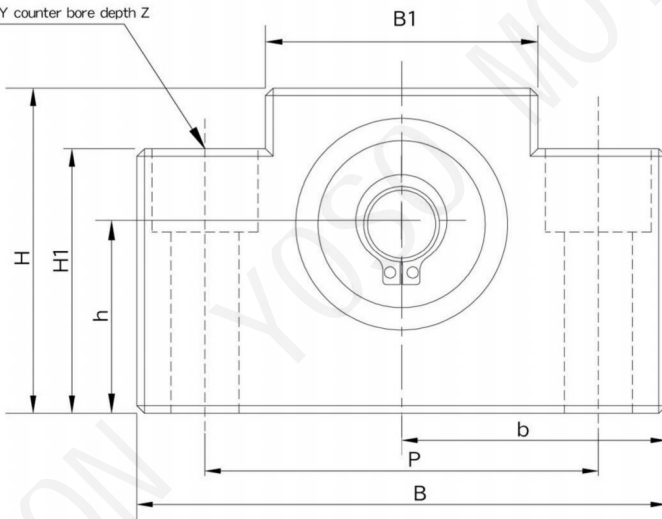

Unit:mm

Model No.	Shaft diameter	L	B	H	b	h	B1	H1	P	X	Y	Z	Bearing	Snap ring	Weight (Kgs)
					± 0.02	± 0.02									
AF10	8	20	70	43	35	6	36	35	52	9	14	11	608ZZ	S 08	0.36
AF12	10	20	70	43	35	25	36	35	52	9	14	11	6000ZZ	S 10	0.36
AF15	15	20	80	50	40	30	41	40	60	9	14	11	6002ZZ	S 15	0.44
AF20	20	26	95	58	47.5	30	56	45	75	11	17	15	6204ZZ	S 20	0.73
AF25	25	30	105	68	52.5	35	66	25	85	11	-	-	6205ZZ	S 25	0.95

Support Unit AF (supported-side rectangular type)

■ Support Unit AF (supported-side rectangular type)

Order Coding	Model No.	Surface treatment	Applicable ballscrew accuracy grade	Bearing	Delivery date	
AF10_C3	AF10	Black Oxide	C3~C7	608ZZ	EX-STOCK	 Black Oxide (Application:Generalcase)
AF10_C3N		Electroless Nickel Plating	C3~C7	608W	3 days	
AF12_C3	AF12	Black Oxide	C3~C7	6000ZZ	EX-STOCK	 ElectrolessNickel Plating (Application:Clean room)
AF12_C3N		Electroless Nickel Plating	C3~C7	6000W	3 days	
AF15_C3	AF15	Black Oxide	C3~C7	6002ZZ	EX-STOCK	 Electroless Nickel Plating (Application:Clean room)
AF15_C3N		Electroless Nickel Plating	C3~C7	6002W	EX-STOCK	
AF20_C3	AF20	Black Oxide	C3~C7	6204ZZ	EX-STOCK	 Electroless Nickel Plating (Application:Clean room)
AF20_C3N		Electroless Nickel Plating	C3~C7	6204W	3 days	
AF25_C3	AF25	Black Oxide	C3~C7	6205ZZ	EX-STOCK	 Black Oxide (Application:General case)
AF25_C3N		Electroless Nickel Plating	C3~C7	6205W	3 days	

Note;

- 1.It is used double pressed steel cagesfor Black Oxidetype support units.
- 2.It is used double plastic cages forElectroless Nickel Plating type support units.
- 3.All of bearings use Japanese &Taiwanese brand bearings

■ Support Unit Bk (fixed-side rectangular type)

No.	Part name	Qty
1	Housing	1
2	Bearing	1 set
3	Holding lid	1
4	Collar	2
5	Seal	2
6	Lock nut	1 set
7	Cushion Stopper (option)	1

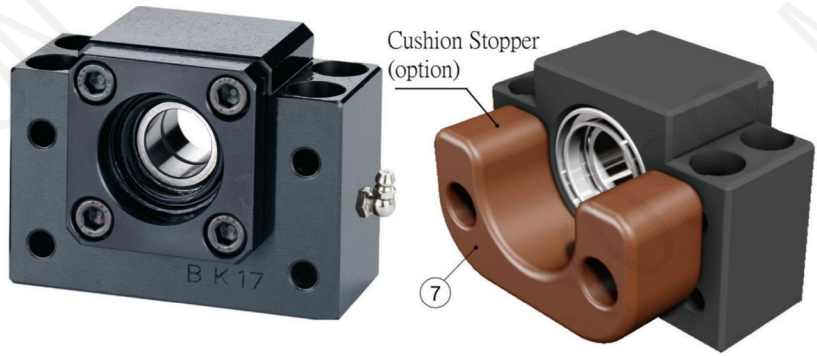

BK10~BK20

BK

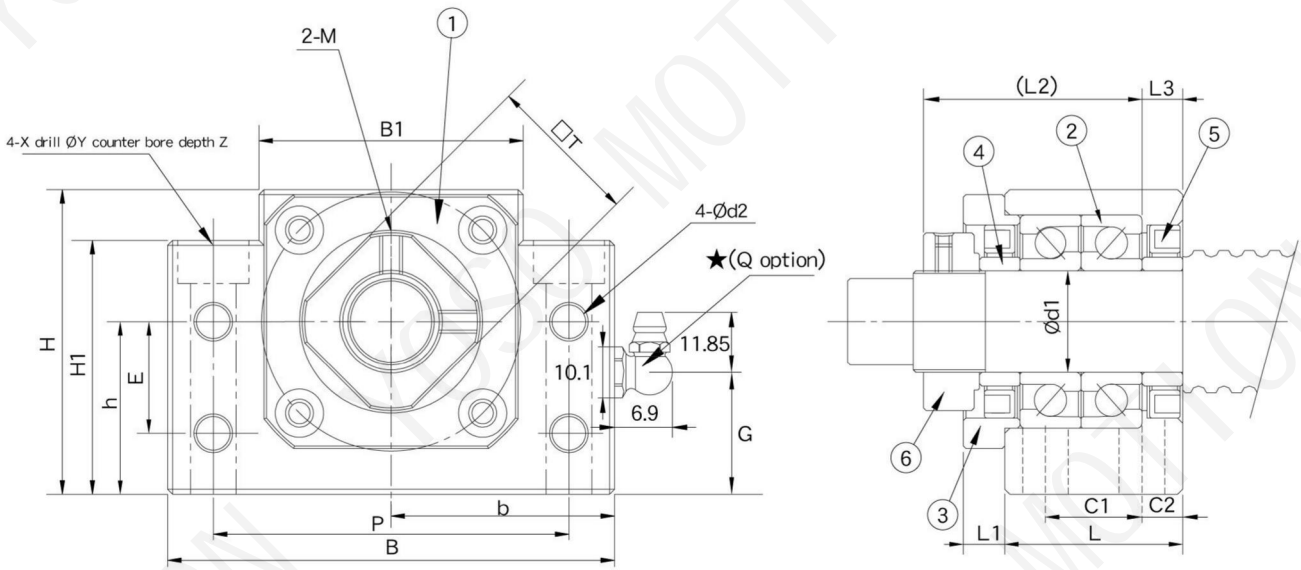

Unit:mm

Model No.	Shaft diamete	L	L1	L2	L3	B	H	b ±002	h ±002	B1	H1	E	P	C1	C2	d2	X	Y	Z	M	T	G	Q	Weight (Kgs)
BK10	10	25	5	29.5	5	60	39	30	22	34	32.5	15	46	13	6	5.5	6.6	10.8	5	M3	16	15	M6	0.4
BK12	12	25	5	29.5	5	60	43	30	25	34	32.5	18	46	13	6	5.5	6.6	10.8	1.5	M4	19	18	M6	0.41
BK15	15	27	6	32	6	70	48	35	28	40	38	18	54	15	6	5.5	6.6	11	6.5	M4	22	18	M6	0.58
BK17	17	35	9	44	7	86	64	43	39	50	55	28	68	19	8	6.6	9	14	8.5	M4	24	30	M6	1.3
BK20	20	35	8	43	8	88	60	44	34	52	50	22	70	19	8	6.6	9	14	8.5	M4	30	24	M6	1.2
BK25	25	42	12	54	9	106	80	53	48	64	70	33	85	22	10	9	11	17	11	M6	35	37	M6	2.35
BK30	30	45	14	61	9	128	89	64	51	76	78	33	102	23	11	11	14	20	13	M6	40	37	M6	3.33
BK35	35	50	14	67	12	140	90	70	52	88	79	35	114	26	12	11	14	20	13	M6	50	37	M6	4.4
BK40	40	61	18	76	16	160	110	70	60	100	90	37	130	33	14	14	18	26	17.5	M6	50	43	M6	6.8

Support Unit Bk (fixed-side rectangular type)

■ Support Unit Bk (fixed-side rectangular type)

Order Coding	Model No.	Surface treatment	Applicable ballscrew accuracy grade	Bearing		Delivery date
				Model No.	Max. Starting torque (gf-cm)	
BK10	BK10	Black Oxide	C3~C10	7000AP5	190	EX-STOCK
BK10_C5			C5~C10	7000AP0	190	EX-STOCK
BK10_C3			C3	7000AP5	190	EX-STOCK
BK10_N		Electroless Nickel Plating	C3~C10	7000AP5	190	EX-STOCK
BK10_C5N			C5~C10	7000AP0	190	3 days
BK10_C3N			C3	7000AP5	190	3 days
BK12	BK12	Black Oxide	C3~C10	7001AP5	210	EX-STOCK
BK12_C5			C5~C10	7001AP0	210	EX-STOCK
BK12_C3			C3	7001AP5	210	EX-STOCK
BK12_N		Electroless Nickel Plating	C3~C10	7001AP5	210	EX-STOCK
BK12_C5N			C5~C10	7001AP0	210	EX-STOCK
BK12_C3N			C3	7001AP5	210	3 days
BK15	BK15	Black Oxide	C3~C10	7002AP5	230	EX-STOCK
BK15_C5			C5~C10	7002AP0	230	EX-STOCK
BK15_C3			C3	7002AP5	230	EX-STOCK
BK15_N		Electroless Nickel Plating	C3~C10	7002AP5	230	EX-STOCK
BK15_C5N			C5~C10	7002AP5	230	EX-STOCK
BK15_C3N			C3	7002AP5	230	3 days
BK17	BK17	Black Oxide	C3~C10	7203AP5	370	EX-STOCK
BK17_C5			C5~C10	7203AP0	370	3 days
BK17_C3			C3	7203AP5	370	3 days
BK17_N		Electroless Nickel Plating	C3~C10	7203AP5	370	EX-STOCK
BK17_C5N			C5~C10	7203AP0	370	3 days
BK17_C3N			C3	7203AP5	370	3 days
BK20	BK20	Black Oxide	C3~C10	7004AP5	380	EX-STOCK
BK20_C5			C5~C10	7004AP0	380	3 days
BK20_C3			C3	7004AP5	380	3 days
BK20_N		Electroless Nickel Plating	C3~C10	7004AP5	380	EX-STOCK
BK20_C5N			C5~C10	7004AP0	380	3 days
BK20_C3N			C3	7004AP5	380	3 days



Black Oxide
(Application:General case)



Electroless Nickel Plating
(Application:Clean room)

Note:

1.All types make Preload.

2.All of bearings use Japanese & Taiwanese brand bearings(Model No.in blue) Assembly by DFway.The most suitable way for ballscrew use

3.The standard type is without Q;if required,please advise in advance.

■ Support Unit BK (fixed-side rectangular type)

Order Coding	Model No.	Surface treatment	Applicable ballscrew accuracy grade	Bearing		Delivery date
				Model No.	Max.Starting torque (gf-cm)	
BK25	BK25	Black Oxide	C3 - C10	7205A P5	730	EX-STOCK
BK25_C5			C5 - C10	7205A P0	730	EX-STOCK
BK25B_C5			C5 - C10	7205B P0	730	EX-STOCK
BK25_C3			C3	7205A P5	730	EX-STOCK
BK25_N		Electroless Nickel Plating	C3 - C10	7205A P5	730	EX-STOCK
BK25_C5N			C5 - C10	7205A P0	730	3 days
BK25B_C5N			C5 - C10	7205B P0	730	3 days
BK25_C3N			C3	7205A P5	730	3 days
BK30_C5	BK30	Black Oxide	C5 - C10	7206A P0	1050	EX-STOCK
BK30B_C5			C5 - C10	7206B P0	1050	EX-STOCK
BK30_C5N		Electroless Nickel Plating	C5 - C10	7206A P0	1050	EX-STOCK
BK30B_C5N	C5 - C10		7206B P0	1050	3 days	
BK35_C5	BK35	Black Oxide	C5 - C10	7207B P0	1320	EX-STOCK
BK35_C5N		Electroless Nickel Plating	C5 - C10	7207B P0	1320	3 days
BK40_C5	BK40	Black Oxide	C5 - C10	7208B P0	2050	EX-STOCK
BK40_C5N		Electroless Nickel Plating	C5 - C10	7208B P0	2050	EX-STOCK



Note:

- 1.All types make Preload.
- 2.All of bearings use Japanese & Taiwanese brand bearings (Model No. in blue) Assembly by DFway. The most suitable way for ballscrew use
- 3.The standard type is without Q, if required, please advise in advance.

Support Unit BF (supported side rectangular type)

■ Support Unit BF (supported side rectangular type)

No.	Part name	Qty
1	Housing	1
2	Bearing	1set
3	Snap ring	1
4	Cushion Stopper (option)	1

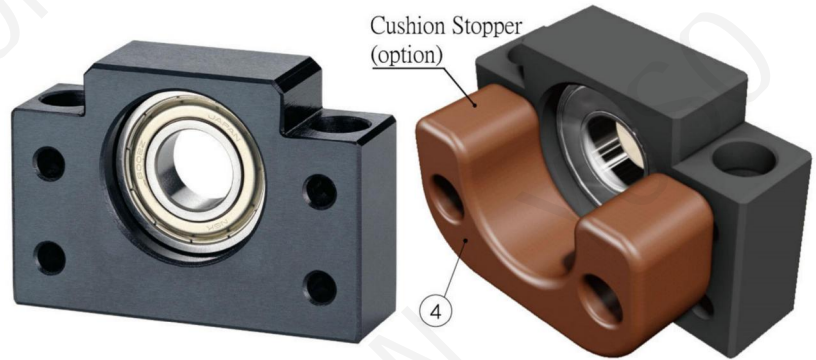

BF10~BF13

BF

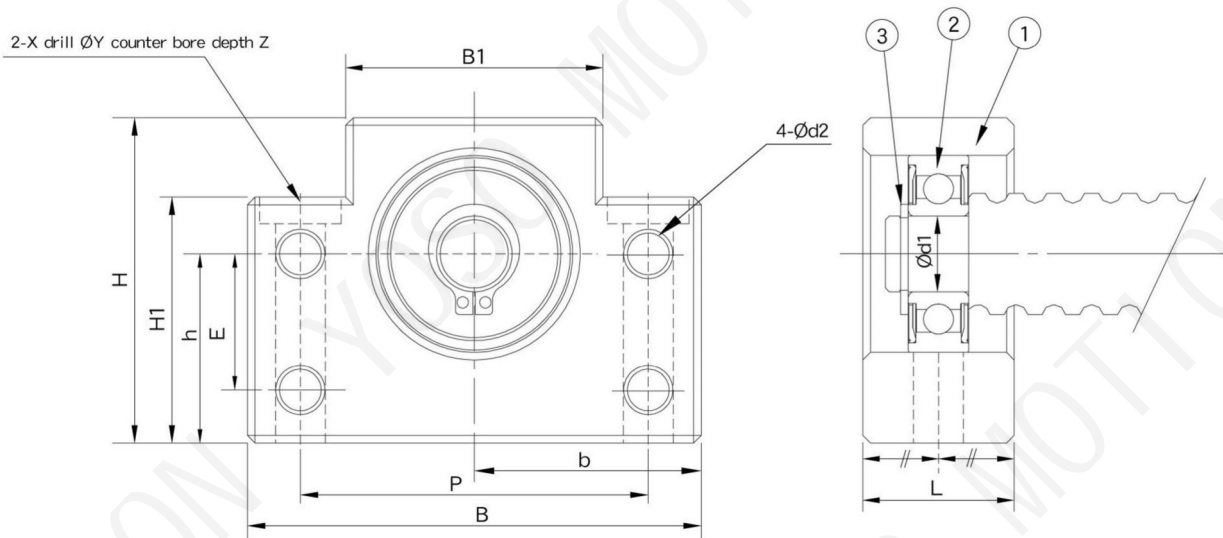

Unit:mm

Model No.	Shaft diameter	L	B	H	b ±0.02	h ±0.02	B1	H1	E	P	Ø E	X	Y	Z	Bearing	Snap ring	Weight (Kgs)
BF10	8	20	60	39	30	22	34	32.5	15	46	5.5	6.6	10.8	5	608ZZ	S 08	0.3
BF12	10	20	60	43	30	25	34	32.5	18	46	5.5	6.6	10.8	1.5	6000ZZ	S 10	0.3
BF15	15	20	70	48	35	28	40	38	18	54	5.5	6.6	11	6.5	6002ZZ	S 15	0.4
BF17	17	23	86	64	43	39	50	55	28	68	6.6	9	14	8.5	6203ZZ	S 17	0.75
BF20	20	6	88	60	44	34	52	50	22	70	6.6	9	14	8.5	6004Z7	S 20	0.76
BF20H	20	26	88	74	44	48	52	64	-	70	-	9	14	8.5	6004ZZ	S20	1.02
BF25	25	30	106	80	53	48	64	70	33	85	9	-	17	11	6205ZZ	S 25	1.43
SF25	25	32	128	89	64	51	76	78	-	102	-	14	00	13	6205ZZ	S 25	-
BF30	30	32	128	89	64	51	76	78	33	102	11	14	20	13	6206ZZ	S 30	1.94
BF35	35	32	140	96	70	52	88	79	35	114	11	14	20	13	6207ZZ	S 35	2.25
SF40	40	32	140	06	70	52	88	79	-	114	-	14	20	13	6208ZZ	S 40	-
BF40	40	37	160	110	80	60	100	90	37	130	14	18	26	17.5	6208ZZ	S 40	3.3

■ Support Unit BF (Supported-side rectangular type)

Order Coding	Model No.	Surface treatment	Applicable ballscrew accuracy grade	Bearing	Delivery date	
BF10_C3	BF10	Black Oxide	C3~C7	608ZZ	EX-STOCK	 Black Oxide (Application:General case)
BF10_C3N		Electroless Nickel Plating	C3~C7	608VV	EX-STOCK	
BF12_C3	BF12	Black Oxide	C3~C7	6000ZZ	EX-STOCK	
BF12_C3N		Electroless Nickel Plating	C3~C7	6000VV	EX-STOCK	
BF15_C3	BF15	Black Oxide	C3~C7	6002ZZ	EX-STOCK	
BF15_C3N		Electroless Nickel Plating	C3~C7	6002VV	EX-STOCK	
BF17_C3	BF17	Black Oxide	C3~C7	6203ZZ	EX-STOCK	
BF17_C3N		Electroless Nickel Plating	C3~C7	6203VV	EX-STOCK	
BF20_C3	BF20	Black Oxide	C3~C7	6004ZZ	EX-STOCK	 Electroless Nickel Plating (Application:Clean room)
BF20_C3N		Electroless Nickel Plating	C3~C7	6004VV	EX-STOCK	
BF25_C3	BF25	Black Oxide	C3~C7	6205ZZ	EX-STOCK	
BF25_C3N		Electroless Nickel Plating	C3~C7	6205VV	EX-STOCK	
BF30_C3	BF30	Black Oxide	C3~C7	6206ZZ	EX-STOCK	
BF30_C3N		Electroless Nickel Plating	C3~C7	6206VV	EX-STOCK	
BF35_C3	BF35	Black Oxide	C3~C7	6207ZZ	EX-STOCK	
BF35_C3N		Electroless Nickel Plating	C3~C7	6207VV	EX-STOCK	
BF40_C3	BF40	Black Oxide	C3~C7	6208ZZ	EX-STOCK	
BF40_C3N		Electroless Nickel Plating	C3~C7	6208VV	EX-STOCK	

Note :

- 1.It is used double pressed steel cages for Black Oxide type support units.
- 2.It is used double plastic cages for Electroless Nickel Plating type support units.
- 3.All of bearings use Japanese & Taiwanese brand bearings

Support Unit Ek (fixed-side rectangular type)

■ Support Unit Ek (fixed-side rectangular type)

EK05

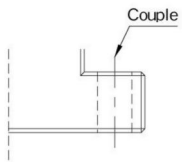

No.	Part name	Qty
1	Housing	1
2	Bearing	1 set
3	Holding lid	1
4	Collar	2
5	Seal	1(2)
6	Lock nut	1
7	Cushion Stopper(option)	1
8	Cushion Stopper (option)	2

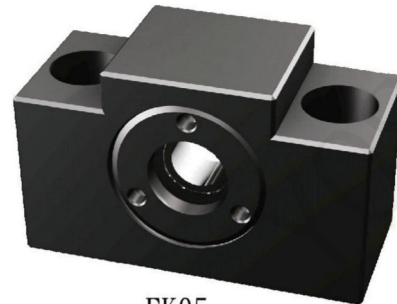

EK05

EK06~EK08

2-ØX drill ØY counter bore depth Z

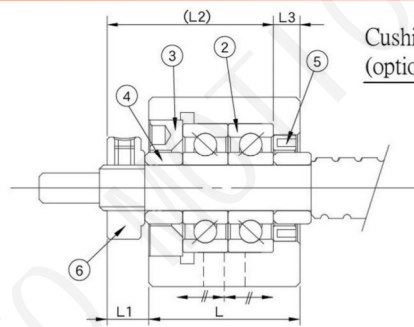
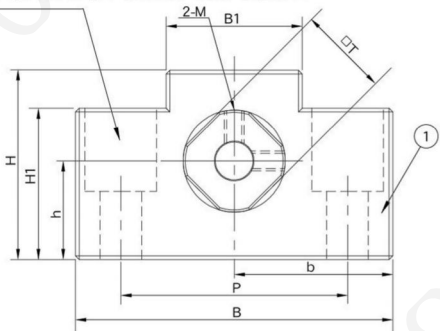

Cushion Stopper (option)

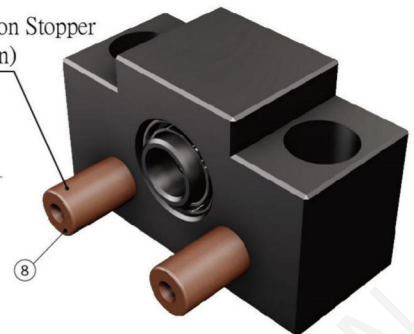

(EK06~08)

EK10~EK20

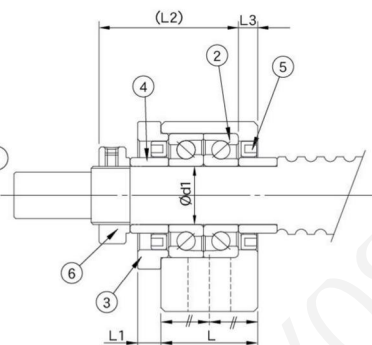
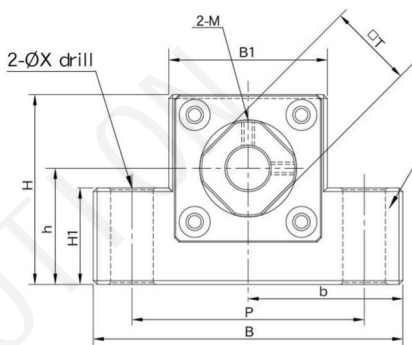

Cushion Stopper (option)



(EK10~20)

Unit:mm

Model No.	Shaft diameter d1	L	L1	L2	L3	B	H	b	h	B1	H1	P	X	Y	Z	M	T	Weight (kgs)
EK05	5	16.5	5.5	18.5	3.5	36	21	18	11	20	8	28	4.5	-	-	M3	11	0.1
EK06	6	20	5.5	22	3.5	42	25	21	13	26	20	30	5.5	9.5	11	M3	1	0.15
EK08	8	23	7	26	4	52	32	26	17	25	26	38	6.6	11	12	M3	14	0.26
EK10-1	10	24	6	29.5	6	65	43	32.5	21	36	20	52	6.6	-	-	M3	16	0.45
EK10	10	24	6	29.5	6	70	43	35	25	36	24	52	9	-	-	M3	16	0.45
EK12	12	24	6	29.5	6	70	43	35	25	36	24	52	9	-	-	M4	19	0.44
EK15	15	25	6	36	5	80	50	40	30	41	25	60	11	-	-	M4	22	0.56
EK20	20	42	10	50	10	95	58	47.5	30	56	25	75	11	-	-	M4	30	1.34

■ Support Unit EK (fixed-side rectangular type)

Order Coding	Model No.	Surface treatment	Applicable ballscrew accuracy grade	Bearing		Delivery date	 Black Oxide (Application:General case)
				Model No.	Max.Starting torque		
EK06	EK06	Black Oxide	C3~C10	706A P5	50	EX-STOCK	 Electroless Nickel Plating (Application:Clean room)
EK06_C5			C5~C10	706A P0	50	EX-STOCK	
EK06_C3			C3	706A P5	50	3 days	
EK06_N		Electroless Nickel Plating	C3~C10	706A P5		3 days	
EK06_C5N			C5~C10	706A P0	50	3 days	
EK06_C3N			C3	706A P5	50	3 days	
EK08	EK08	Black Oxide	C3~C10	708A P5	90	EX-STOCK	 Electroless Nickel Plating (Application:Clean room)
EK08_C5			C5~C10	708A P0	90	EX-STOCK	
EK08_C3			C3	708A P5	90	EX-STOCK	
EK08_N		Electroless Nickel Plating	C3~C10	708A P5	90	EX-STOCK	
EK08_C5N			C5~C10	708A P0	90	3 days	
EK08_C3N			C3	708A P5	90	3 days	
EK10	EK10	Black Oxide	C3~C10	7000A P5	190	EX-STOCK	 Black Oxide (Application:General case)
EK10_C5			C5~C10	7000A P0	190	EX-STOCK	
EK10_C3			C3	7000A P5	190	EX-STOCK	
EK10_N		Electroless Nickel Plating	C3~C10	7000A P5	190	EX-STOCK	
EK10_C5N			C5~C10	7000A P0	190	3 days	
EK10_C3N			C3	7000A P5	190	3 days	
EK12	EK12	Black Oxide	C3~C10	7001A P5	210	EX-STOCK	 Electroless Nickel Plating (Application:Clean room)
EK12_C5			C5~C10	7001A P0	210	EX-STOCK	
EK12_C3			C3	7001A P5	210	EX-STOCK	
EK12_N		Electroless Nickel Plating	C3~C10	7001A P5	210	EX-STOCK	
EK12_C5N			C5~C10	7001A P0	210	3 days	
EK12_C3N			C3	7001A P5	210	3 days	

Note:

- 1.All types make Preload.
 - 2.All of bearings use Japanese & Taiwanese brand bearings (Model No. in blue).
- Assembly by DF way. The most suitable way for ballscrew use.

Support Unit EK (fixed-side rectangular type)

■ Support Unit EK (fixed-side rectangular type)

Order Coding	Model No.	Surface treatment	Applicable ballscrew accuracy grade	Bearing		Delivery date
				Model No.	Max.Starting torque(gf-cm)	
EK15	EK15	Black Oxide	C3~C10	7002A P5	230	EX-STOCK
EK15_C5			C5~C10	7002A P0	230	EX-STOCK
EK15_C3			C3	7002A P5	230	EX-STOCK
EK15_N		Electroless Nickel Plating	C3~C10	7002A P5	230	EX-STOCK
EK15_C5N			C5~C10	7002A P0	230	3 days
EK15_C3N			C3	7002A P5	230	3 days
EK20	EK20	Black Oxide	C3~C10	7204A P5	550	EX-STOCK
EK20_C5			C5~C10	7204A P0	550	3 days
EK20B_C5			C5~C10	7204B P0	550	EX-STOCK
EK20_C3			C3	7204A P5	550	3 days
EK20_N		Electroless Nickel Plating	C3~C10	7204A P5	550	EX-STOCK
EK20_C5N			C5~C10	7204A P0	550	3 days
EK20B_C5N			C5~C10	7204B P0	550	3 days
EK20_C3N			C3	7204A P5	550	3 days



Note:

- 1.All types make Preload.
- 2.All of bearings use Japanese & Taiwanese brand bearings(Model No.in blue) .
Assembly by DFway.The most suitable way for ballscrew use

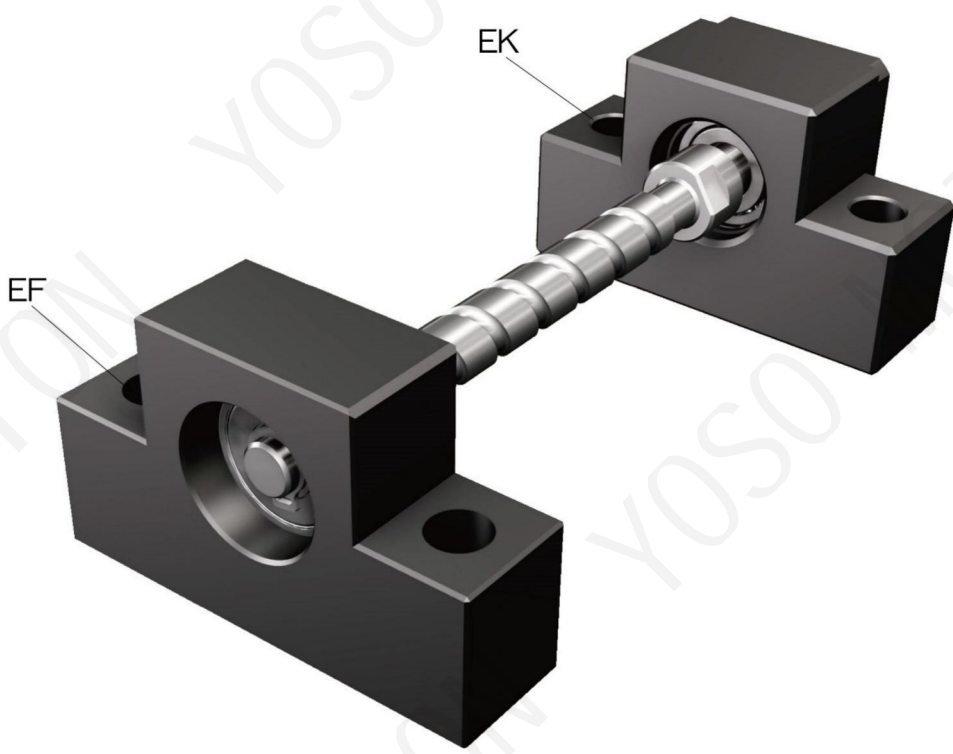

■ Support Unit EF (fixed-side rectangular type)

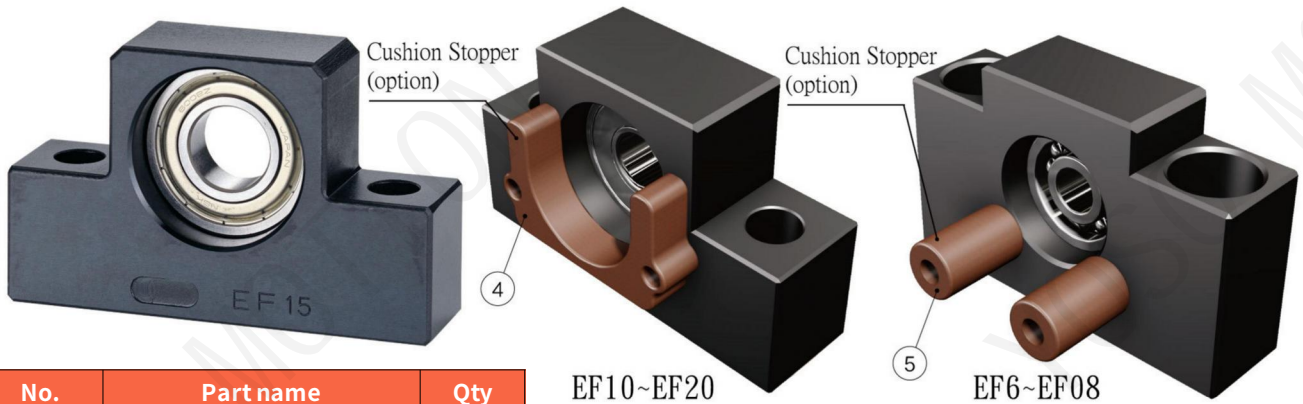

No.	Part name	Qty
1	Housing	1
2	Bearing	1set
3	Snap ring	1
4	Cushion Stopper (option)	1
5	Cushion Stopper (option)	2

EF05

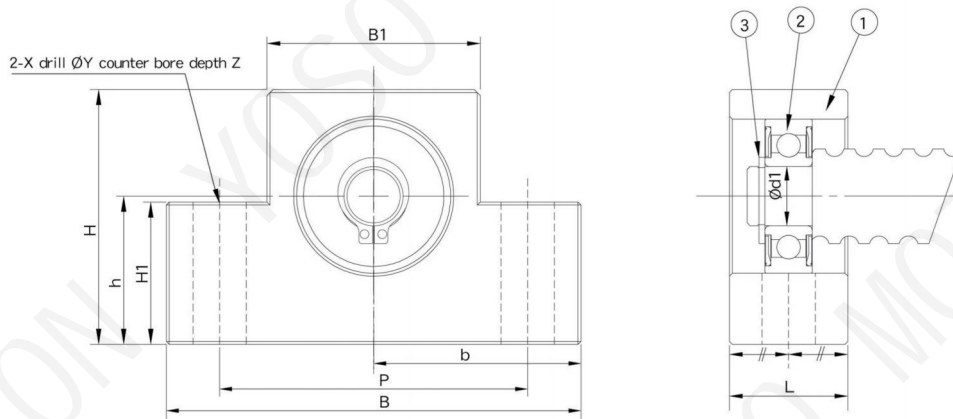







Unit:mm

Model No.	Shaft diameter d1	L	B	H	b	h	B1	H1	P	Y	Z	Bearing	Snap ring	Weight (Kgs)	
					±0.02	+0.02									
EF06	6	12	42	25	21	13	18	20	30	5.5	9.5	11	606ZZ	S 06	0.1
EF08	6	14	52	32	26	17	25	26	38	6.6	11	12	606ZZ	C 06	0.15
EF10	8	20	70	43	35	25	36	24	52	9	-	-	608ZZ	S 08	0.33
EF12	10	20	70	43	35	25	36	24	52	9	-	-	6000ZZ	S 10	0.32
EF15	16	20	80	50	40	30	41	25	60	9	-	-	6002ZZ	S 15	0.38
EF20	20	26	95	58	47.5	30	56	25	75	11	-	-	6204ZZ	S 20	0.64

Support Unit EF (fixed-side rectangular type)

■ Support Unit EF (fixed-side rectangular type)

Order Coding	Model No.	Surface treatment	Applicable ballscrew accuracy grade	Bearing	Delivery date	
EF06_C3	EF06	Black Oxide	C3~C7	606ZZ	EX-STOCK	 <p>Black oxide (Application;General case)</p>
EF06_C3N		Electroless Nickel Plating	C3~C7	606VV	3 days	
EF08_C3	EF08	Black Oxide	C3~C7	606ZZ	EX-STOCK	 <p>Electroless Nickel Plating (Application:Cleanroom)</p>
EF08_C3N		Electroless Nickel Plating	C3~C7	606VV	EX-STOCK	
EF10_C3	EF10	Black Oxide	C3~C7	608ZZ	EX-STOCK	 <p>Electroless Nickel Plating (Application:Cleanroom)</p>
EF10_C3N		Electroless Nickel Plating	C3~C7	608VV	EX-STOCK	
EF12_C3	EF12	Black Oxide	C3~C7	6000ZZ	EX-STOCK	 <p>Electroless Nickel Plating (Application:Cleanroom)</p>
EF12_C3N		Electroless Nickel Plating	C3~C7	6000VV	EX-STOCK	
EF15_C3	EF15	Black Oxide	C3~C7	6002ZZ	EX-STOCK	 <p>Electroless Nickel Plating (Application:Cleanroom)</p>
EF15_C3N		Electroless Nickel Plating	C3~C7	6002VV	EX-STOCK	
EF20_C3	EF20	Black Oxide	C3~C7	6204ZZ	EX-STOCK	 <p>Electroless Nickel Plating (Application:Cleanroom)</p>
EF20_C3N		Electroless Nickel Plating	C3~C7	6204VV	EX-STOCK	

Note:

- 1.It is used double pressed steel cages for Black Oxide type support units.
- 2.It is used double plastic cages for Electroless Nickel Plating type support units.
- 3.All of bearings use Japanese & Taiwanese brand bearings.

■ Support Unit FK (fixed-side rectangular type)

No.	Part name	Qty
1	Housing	1
2	Bearing	1set
3	Holding lid	1
4	Collar	2
5	Seal	1
6	Lock nut	1set



FK05~FK08

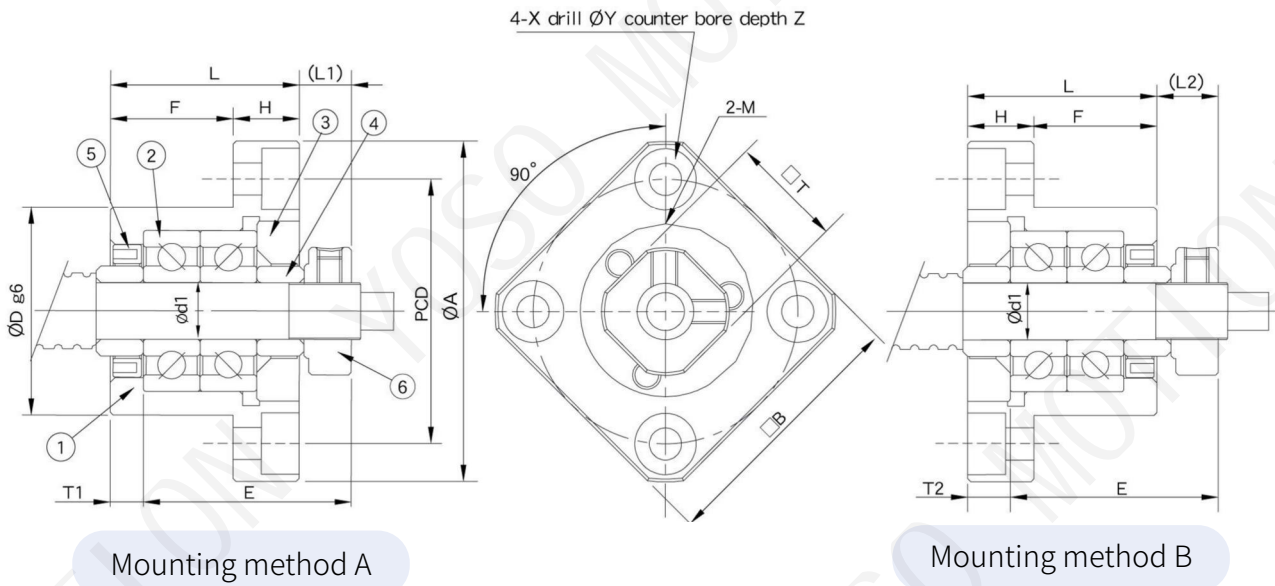

Unit:mm

Model No.	Shaft diameter d1	L	H	F	E	Dog6	PCL	B	Mounting method A		Mounting method B		X	Y	Z	M	T	Weight (Kgs)	
									L1	T1	L2	T2							
FK05	5	16.5	6	10.5	18.5	20 -0.007 -0.02	34	26	26	5.5	3.5	5	3	3.4	6.5	3.5	M3	11	0.08
FK06	6	20	7	13	22	28 -0.007 -0.02	36	28	28	5.5	3.5	6.5	4.5	3.4	6.5	4	M3	12	0.1
FK08	8	23	9	14	26	28 -0.007 -0.02	43	35	35	7	4	8	5	3.4	6.5	4	M3	14	0.15

Support Unit FK (fixed-side round type)

■ Support Unit FK (fixed-side round type)



No.	Part name	Qty
1	Housing	1
2	Bearing	1set
3	Holding lid	1
4	Collar	2
5	Seal	2
6	Lock nut	1set

The position of oil grease is for reference only, please visit our website to get more information on it.

FK10~FK30

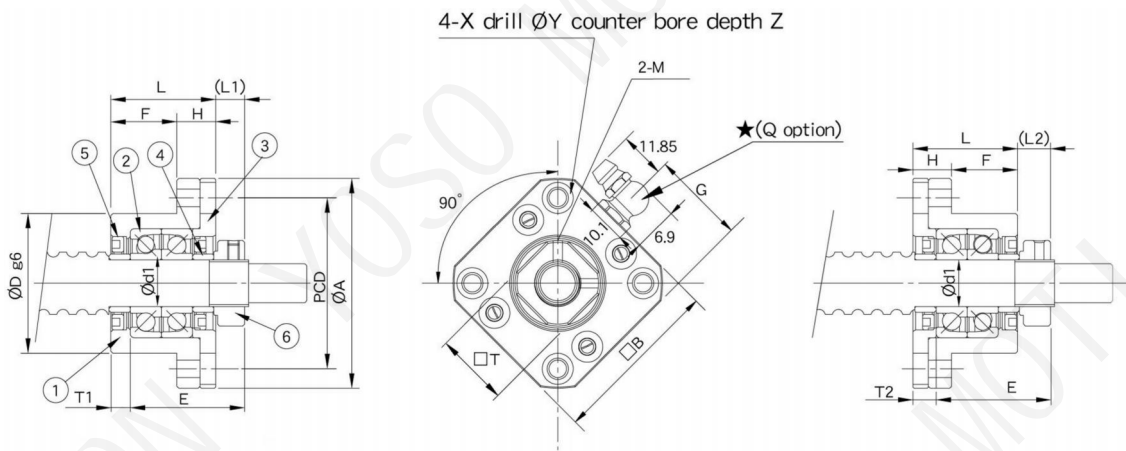

Mounting method A

Mounting method B

Model No.	Shaft diameter d1	L	H	F	E	Dg6	A	PCD	B	Moun ting od A		Mounting method B		X	Y	Z	M	T	G	Q	Weight (Kgs)	
										L1	T1	L2	T2									
FK10	10	27	10	17	29.5	34	-0.009 -0.025	52	42	42	7.5	5	8.5	6	4.5	8	4	M3	16	-	-	0.23
FK12	12	27	10	7	29.5	36	-0.009 -0.025	54	44	44	7.5	5	8.5	6	4.5	8	4	M4	19	-	-	0.25
FK15	15	32	15	17	36	40	-0.009 -0.025	63	50	52	100	6	12	8	5.5	9.5	6	M4	22	26	M6	0.39
FK17	17	45	22	23	47	50	-0.009 -0.025	77	62	61	11	9	14	12	6.6	11	10 U	M4	24	30.5	M6	0.81
FK20	20	52	22	30	50	57	-0.010 -0.029	Q6 0	70	68	8	10	12	14	6.6	11	10 10	M4	30	34	M6	1.02
FK25	25	57	27	20 0	59	63	-0.010 -0.029	98	80	79	13	10	20	17	9	15	12 10	M5	35	39.5	M6	1.48
FK30	30	62	30	2 0	61	75	-0.010 -0.029	117	95	93	11	12	17	18	11	17.5	15	M6	40	46.5	M6	2.32

■ Support Unit FK (fixed-side round type)

Order Coding	Model No.	Surface treatment	Applicable ballscrew accuracy grade	Bearing		Delivery date
				Model No	Max.Starting torque (gf-cm)	
FK06	FK06	Black Oxide	C3~C10	706A P5	50	EX-STOCK
FK06_C5			C5~C10	706A P0	50	EX-STOCK
FK06_C3			C3	706A P5	50	EX-STOCK
FK06_N		Electroless Nickel Plating	C3~C10	706A P5	50	3 days
FK06_C5N			C5~C10	706A P0	50	3 days
FK06_C3N			C3	706A P5	50	3 days
FK08	FK08	Black Oxide	C3~C10	708A P5	90	EX-STOCK
FK08_C5			C5~C10	708A P0	90	EX-STOCK
FK08_C3			C3	708A P5	90	EX-STOCK
FK08_N		Electroless Nickel Plating	C3~C10	708A P5	90	EX-STOCK
FK08_C5N			C5~C10	708A P0	90	3 days
FK08_C3N			C3	708A P5	90	3 days
FK10	FK10	Black Oxide	C3~C10	7000A P5	190	EX-STOCK
FK10_C5			C5~C10	7000A P0	190	EX-STOCK
FK10_C3			C3	7000A P5	190	EX-STOCK
FK10_N		Electroless Nickel Plating	C3~C10	7000A P5	190	EX-STOCK
FK10_C5N			C5~C10	7000A P0	190	3 days
FK10_C3N			C3	7000A P5	190	3 days
FK12	FK12	Black Oxide	C3~C10	7001A P5	210	EX-STOCK
FK12_C5			C5~C10	7001A P0	210	EX-STOCK
FK12_C3			C3	7001A P5	210	EX-STOCK
FK12_N		Electroless Nickel Plating	C3~C10	7001A P5	210	EX-STOCK
FK12_C5N			C5~C10	7001A P0	210	EX-STOCK
FK12_C3N			C3	7001A P5	210	EX-STOCK
FK15	FK15	Black Oxide	C3~C10	7002A P5	230	EX-STOCK
FK15_C5			C5~C10	7002A P0	230	EX-STOCK
FK15_C3			C3	7002A P5	230	EX-STOCK
FK15_N		Electroless Nickel Plating	C3~C10	7002A P5	230	EX-STOCK
FK15_C5N			C5~C10	7002A P0	230	EX-STOCK
FK15_C3N			C3	7002A P5	230	3 days



Black oxide
(Application;General case)



Electroless Nickel Plating
(Application:Cleanroom)



Black oxide
(Application;General case)



Electroless Nickel Plating
(Application:Cleanroom)

Note:

1.All types make Preload.

2.All of bearings use Japanese & Taiwanese brand bearings(Model No.in blue).

Assembly by DFway.The most suitable way for ballscrew use

Support Unit FK (fixed-side round type)

■ Support Unit FK (fixed-side round type)

Order Coding	Model No.	Surface treatment	Applicable ballscrew accuracy grade	Bearing		Delivery date
				Model No.	Max Starting torqueE (gf-cm)	
FK17	FK17	Black Oxide	C3~C10	7203A P5	370	EX-STOCK
FK17_C5			C5~C10	7203A P0	370	3 days
FK17_C3			C3	7203A P5	370	3 days
FK17_N		Electroless Nickel Plating	C3~C10	7203A P5	370	EX-STOCK
FK17_C5N			C5~C10	7203A P0	370	3 days
FK17_C3N			C3	7203A P5	370	3 days
FK20	FK20	Black Oxide	C3~C10	7204A P5	550	EX-STOCK
FK20_C5			C5~C10	7204A P0	550	EX-STOCK
FK20B_C5			C5~C10	7204B P0	550	EX-STOCK
FK20_C3			C3	7204A P5	550	EX-STOCK
FK20_N		Electroless Nickel Plating	C3~C10	7204A P5	550	EX-STOCK
FK20_C5N			C5~C10	7204A P0	550	3 days
FK20B_C5N			C5~C10	7204B P0	550	3 days
FK20_C3N			C3	7204A P5	550	3 days
FK25	FK25	Black Oxide	C3~C10	7205A P5	730	EX-STOCK
FK25_C5			C5~C10	7205A P0	730	EX-STOCK
FK25B_C5			C5~C10	7205B P0	730	EX-STOCK
FK25_C3			C3	7205A P5	730	3 days
FK25_N		Electroless Nickel Plating	C3~C10	7205A P5	730	EX-STOCK
FK25_C5N			C5~C10	7205A P0	730	3 days
FK25B_C5N			C5~C10	7205B P0	730	3 days
FK25_C3N			C3	7205A P5	730	3 days
FK30_C5	FK30	Black Oxide	C5~C10	7206A P0	1050	EX-STOCK
FK30B_C5			C5~C10	7206B P0	1050	EX-STOCK
FK30_C5N		Electroless Nickel Plating	C5~C10	7206A P0	1050	EX-STOCK
FK30B_C5N			C5~C10	7206B P0	1050	3 days



Black oxide
(Application;General case)



Electroless Nickel Plating
(Application:Cleanroom)

Note:

- 1.All types make Preload.
- 2.All of bearings use Japanese & Taiwanese brand bearings(Model No.in blue) .
Assembly by DFway.The most suitable way for ballscrew use
- 3.The standard type is without Q,if required,please advise in advance.

■ Support Unit FF (fixed-side round type)

No.	Part name	Qty
1	Housing	1
2	Bearing	1set
3	Snap ring	1



FF

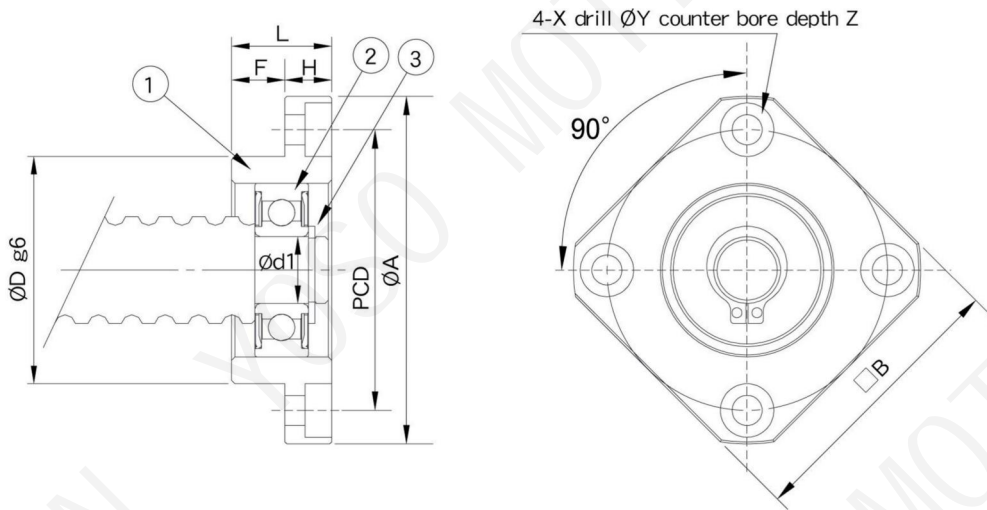

Unit:mm

Model No.	Shaft diameter d1	L	H	F	Dog6	A	PCD	B	X	Y	Z	Bearing	Snap ring	Weight (Kgs)
FF06	6	10	6	4	22 -0.007 -0.02	36	28	28	3.4	6.5	3.5	606ZZ	S 06	0.06
FF10	8	12	7	5	28 -0.007 -0.02	43	35	35	3.4	6.5	4	608ZZ	S 08	0.1
FF12	10	15	7	8	34 -0.009 -0.025	52	42	42	4.5	8	4	6000ZZ	S 10	0.13
FF15	15	17	9	8	40 -0.009 -0.025	63	50	52	5.5	9.5	5.5	6002ZZ	S 15	0.2
FF17	17	20	11	9	50 -0.009 -0.025	77	62	61	6.6	11	6.5	6203ZZ	S17	0.33
FF20	20	20	11	9	57 -0.010 -0.029	85	70	68	6.6	11	6.5	6204ZZ	S 20	0.43
FF25	25	24	14	10	63 -0.010 -0.029	98	80	79	9	14	8.5	6205ZZ	S 25	0.66
FF30	30	27	18	9	75 -0.010 -0.029	117	95	93	11	17	11	6206ZZ	S 30	1.03

Support Unit FF (Supported-side round type)

■ Support Unit FF (Supported-side round type)

Order Coding	Model No.	Surface treatment	Applicable ballscrew accuracy grade	Bearing	Delivery date	
FF06_C3	FF06	Black Oxide	C3~C7	606ZZ	EX-STOCK	 <p>Black oxide (Application;General case)</p>
FF06_C3N		Electroless Nickel Plating	C3~C7	606W	3 days	
FF10_C3	FF10	Black Oxide	C3~C7	608ZZ	EX-STOCK	
FF10_C3N		Electroless Nickel Plating	C3~C7	608W	EX-STOCK	
FF12_C3	FF12	Black Oxide	C3~C7	6000ZZ	EX-STOCK	
FF12_C3N		Electroless Nickel Plating	C3~C7	6000W	EX-STOCK	
FF15_C3	FF15	Black Oxide	C3~C7	6002ZZ	EX-STOCK	 <p>Electroless Nickel Plating (Application:Cleanroom)</p>
FF15_C3N		Electroless Nickel Plating	C3~C7	6002W	EX-STOCK	
FF17_C3	FF17	Black Oxide	C3~C7	6203ZZ	EX-STOCK	
FF17_C3N		Electroless Nickel Plating	C3~C7	6203W	EX-STOCK	
FF20_C3	FF20	Black Oxide	C3~C7	6204ZZ	EX-STOCK	
FF20_C3N		Electroless Nickel Plating	C3~C7	6204W	EX-STOCK	
FF25_C3	FF25	Black Oxide	C3~C7	6205ZZ	EX-STOCK	
FF25_C3N		Electroless Nickel Plating	C3~C7	6205W	EX-STOCK	
FF30_C3	FF30	Black Oxide	C3~C7	6206ZZ	EX-STOCK	
FF30_C3N		Electroless Nickel Plating	C3~C7	6206W	EX-STOCK	

Note

- 1.It is used double pressed steel cages for Black Oxide type support units.
- 2.It is used double plastic cages for Electroless Nickel Plating type support units.
- 3.All of bearings use Japanese & Taiwanese brand bearings

■ Support Unit FKA (fixed-side round type)

No.	Part name	Qty
1	Housing	1
2	Bearing	1set
3	Holding lid	1
4	Collar	2
5	Seal	1~2
6	Lock nut	1set



(FKA06~08)

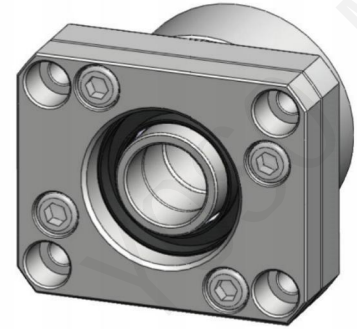

(FKA10~20)

FKA

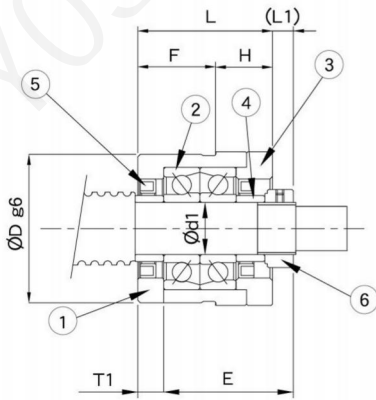

Mounting method A
FKA15H is not applicable

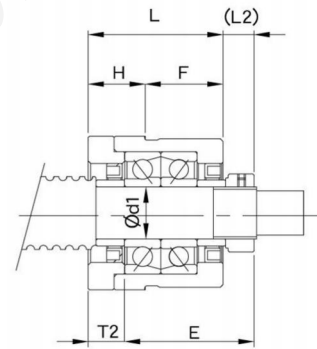
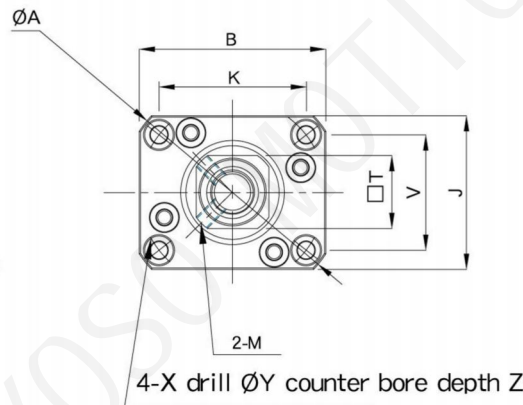

Mounting method A

Unit:mm

Model No	Shaft diameter d1	L	H	F	E	Dg6	A	B	J	K	V	Mounting method A		Mounting method B		X	Y	Z	M	T	Weight Kgs)
												L1	T1	L2	T2						
FKA06	6	20	7	13	22	28 -0.007 -0.02	44	36	30	26.79	20.93	5.5	3.5	6.5	4.5	3.4	0.	4	M3	12	0.14
FKA08	8	23	9	14	26	28 -0.007 -0.02	44	36	30	26.79	20.93	7	4	8	5	3.4	6.5	4	M3	14	0.15
FKA10	10	27	10	17	29.5	26 30 -0.009 -0.025	56	48	39	35.7	27.39	7.5	5	8.5	6	4.5	8	4	M3	16	0.26
FKA12	12	27	10	17	29.5	36 -0.009 -0.025	56	48	39	35.7	27.39	7.5	5	8.5	6	4.5	8	4	M4	19	0.3
FKA15	15	32	15	17	36	40 -0.009 -0.025	65	56	43	39.4	30.78	10	6	12	8	5.5	9.5	6	M4	22	0.37
FKA15H	15	43	17	26	40	50 -0.009 -0.025	77	63	52	49.64	38.79	4	7	7	10	5.5	9.5	8	M4	22	-
FKA20L	20	41	17	24	43	50 -0.009 -0.025	77	63	52	49.64	38.79	9	7	10	10	5.5	9.5	8	M4	30	-
FKA20	20	52	22	30	50	57 -0.010 -0.029	86	72	59	56.74	44.33	8	10	10	14	6.6	11	10	M4	30	1.28

Support Unit FKA (fixed-side round type)

■ Support Unit FKA (fixed-side round type)

Order Codin	Model No.	Surface treatment	Applicable ballscrew accuracy grade	Bearing		Delivery date
				Model No.	Max. Starting torque (gf-cm)	
FKA06	FKA06	Black Oxide	C3~C10	706A P5	50	EX-STOCK
FKA06_C5			C5~C10	706A PO	50	3 days
FKA06_C3			C3	706A P5	50	3 days
FKA06_N		Electroless Nickel Plating	C3~C10	706A P5	50	3 days
FKA06_C5N			C5~C10	706A PO	50	3 days
FKA06_C3N			C3	706A P5	50	3 days
 <p>FKA06~FKA08 Black oxide (Application;General case)</p>						
FKA08	FKA08	Black Oxide	C3~C10	708A P5	90	EX-STOCK
FKA08_C5			C5~C10	708A PO	90	3 days
FKA08_C3			C3	708A P5	90	3 days
FKA08_N		Electroless Nickel Plating	C3~C10	708A P5	90	EX-STOCK
FKA08_C5N			C5~C10	708A PO	90	3 days
FKA08_C3N			C3	708A P5	90	3 days
 <p>FKA06~FKA08 Electroless Nickel Plating (Application:Cleanroom)</p>						
FKA10	FKA10	Black Oxide	C3~C10	7000A P5	190	EX-STOCK
FKA10_C5			C5~C10	7000A PO	190	3 days
FKA10_C3			C3	7000A P5	190	3 days
FKA10_N		Electroless Nickel Plating	C3~C10	7000A P5	190	3 days
FKA10_C5N			C5~C10	7000A PO	190	3 days
FKA10_C3N			C3	7000A P5	190	3 days
 <p>FKA10~FKA20 Black oxide (Application;General case)</p>						
FKA12	FKA12	Black Oxide	C3~C10	7001A P5	210	EX-STOCK
FKA12_C5			C5~C10	7001A PO	210	EX-STOCK
FKA12_C3			C3	7001A P5	210	3 days
FKA12_N		Electroless Nickel Plating	C3~C10	7001A P5	210	EX-STOCK
FKA12_C5N			C5~C10	7001A PO	210	3 days
FKA12_C3N			C3	7001A P5	210	3 days
 <p>FKA10~FKA20 Electroless Nickel Plating (Application:Cleanroom)</p>						

Note:

1.All types make Preload.

2.All of bearings use Japanese & Taiwanese brand bearings(Model No.in blue).

Assembly by DFway.The most suitable way for ballscrew use

■ Support Unit FKA (fixed-side round type)

Order Codin	ModelNo.	Surface treatment	Applicable ballscreW	Bearing		Delivery date
				Model No.	Max.Starting torque (gf-cm)	
FKA15	FKA15	Black Oxide	C3~C10	7002A P5	230	EX-STOCK
FKA15_C5			C5~C10	7002A P0	230	3 days
FKA15_C3			C3	7002A P5	230	3 days
FKA15_N		Electroless Nickel Plating	C3~C10	7002A P5	230	EX-STOCK
FKA15_C5N			C5~C10	7002A P0	230	3 days
FKA15_C3N			C3	7002A P5	230	3 days
FKA15H	FKA15H	Black Oxide	C3~C10	7302A P5	380	EX-STOCK
FKA20L	FKA20L	Black Oxide	C3~C10	7004A P5	380	EX-STOCK
FKA20L_C3			C3	7004A P5	380	3 days
FKA20	FKA20	Black Oxide	C3~C10	7204A P5	550	EX-STOCK
FKA20_C5			C5~C10	7204A P0	550	EX-STOCK
FKA20B_C5			C5~C10	7204B P0	550	3 days
FKA20_C3			C3	7204A P5	550	3 days
FKA20_N		Electroless Nickel Plating	C3~C10	7204A P5	550	EX-STOCK
FKA20_C5N			C5~C10	7204A P0	550	3 days
FKA20B_C5N			C5~C10	7204B P0	550	3 days
FKA20_C3N			C3	7204A P5	550	3 days



FKA10~FKA20
Black oxide
(Application;General case)



FKA10~FKA20
Electroless Nickel Plating
(Application:Cleanroom)

Note:

- 1.All types make Preload.
- 2.All of bearings use Japanese & Taiwanese brand bearings (Model No.in blue) .
Assembly by DFway.The most suitable way for ballscrew use

Low profile Support Unit Lk (fixed-side rectangular type)

■ Low profile Support Unit Lk (fixed-side rectangular type)

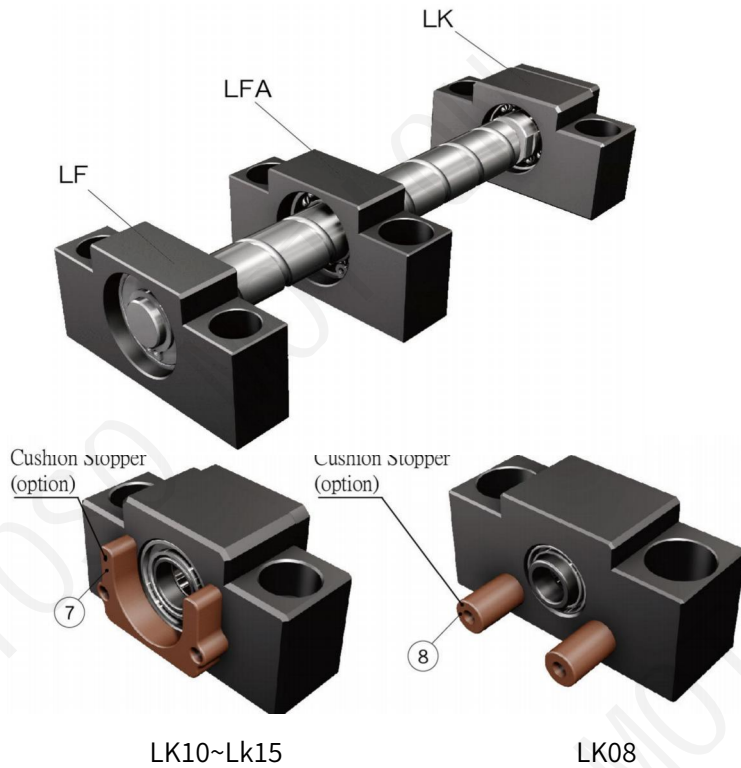

No.	Part name	Qty
1	Housing	1
2	Bearing	1set
3	Holding lid	1
4	Collar	2
5	Seal	2
6	Lock nut	1set
7	Cushion Stopper (option)	1
8	Cushion Stopper (option)	2

LK

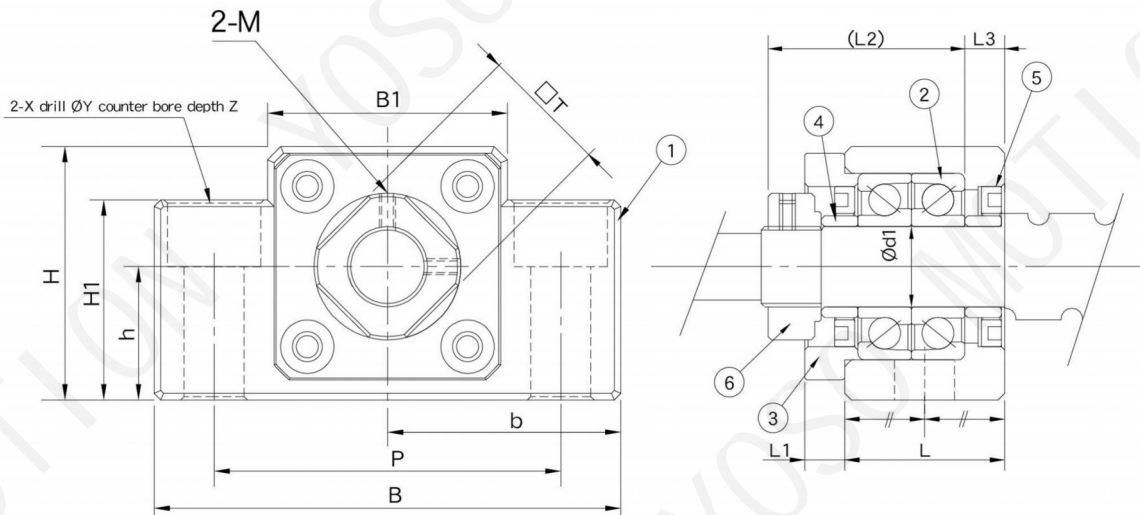

Unit:mm

Model No.	Shaft diameter d1	L	L1	L2	L3	B	H	b ±0.02	h ±0.02	B1	H1	P	X	Y	Z	M	T	Weight (Kgs)
LK08	8	22.5	-	26	3.5	62	31	31	15.5	30	25.5	46	9	14	12.5	M3	14	0.28
LK10	10	24	6	29.5	6	70	38	35	20	36	30	52	9	14	10	M3	16	0.44
LK12	12	24	6	29.5	6	70	38	35	20	36	30	52	9	14	10	M4	19	0.42
LK15	15	25	6	36	5	80	42	40	22	41	32	60	11	17	13	M4	22	0.51

■ Low profile Support Unit LK (fixed-side rectangular type)

Order Coding	Model No.	Surface treatment	Applicable ballscrew accuracy grade	Bearing		Delivery date
				Model No.	Max. Starting torque (gf·cm)	
LK08	LK08	Black Oxide	C3~C10	708A P5	90	EX-STOCK
LK08_C5			C5~C10	708A P0	90	3 days
LK08_C3			C3	708A P5	90	3 days
LK08_N		Electroless Nickel Plating	C3~C10	708A P5	90	3 days
LK08_C5N			C5~C10	708A P0	90	3 days
LK08_C3N			C3	708A P5	90	3 days
LK10	LK10	Black Oxide	C3~C10	7000A P5	190	EX-STOCK
LK10_C5			C5~C10	7000A P0	190	3 days
LK10_C3			C3	7000A P5	190	3 days
LK10_N		Electroless Nickel Plating	C3~C10	7000A P5	190	3 days
LK10_C5N			C5~C10	7000A P0	190	3 days
LK10_C3N			C3	7000A P5	190	3 days
LK12	LK12	Black Oxide	C3~C10	7001A P5	210	EX-STOCK
LK12_C5			C5~C10	7001A P0	210	3 days
LK12_C3			C3	7001A P5	210	3 days
LK12_N		Electroless Nickel Plating	C3~C10	7001A P5	210	3 days
LK12_C5N			C5~C10	7001A P0	210	3 days
LK12_C3N			C3	7001A P5	210	3 days
LK15	LK15	Black Oxide	C3~C10	7002A P5	230	EX-STOCK
LK15_C5			C5~C10	7002A P0	230	3 days
LK15_C3			C3	7002A P5	230	3 days
LK15_N		Electroless Nickel Plating	C3~C10	7002A P5	230	3 days
LK15_C5N			C5~C10	7002A P0	230	3 days
LK15_C3N			C3	7002A P5	230	3 days



Black oxide
(Application;General case)

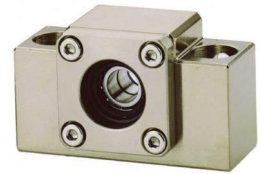

Electroless Nickel Plating
(Application:Cleanroom)

Note:

- 1.All types make Preload.
 - 2.All of bearings use Japanese & Taiwanese brand bearings (Model No. in blue).
- Assembly by DFway. The most suitable way for ballscrew use

Low Profile Support Unit LF / LFA(supported side rectangular type)

Low Profile Support Unit LF / LFA(supported side rectangular type)

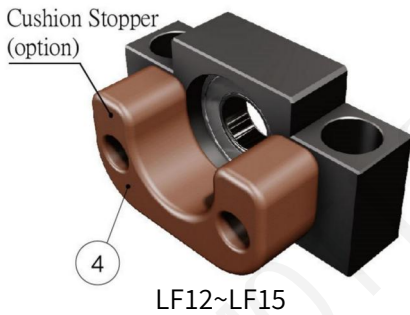

LF12~LF15

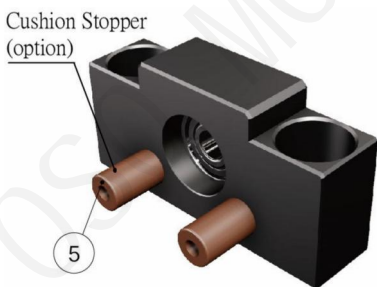
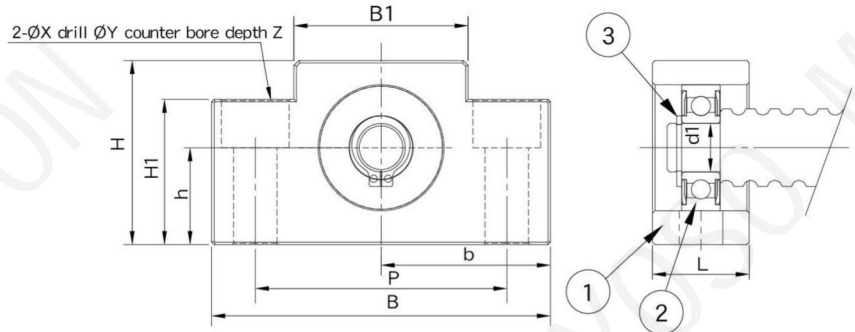

LF08

No.	Part name	Qty
1	Housing	1
2	Bearing	1set
3	Snap ring	1
4	Cushion Stopper (option)	1
5	Cushion Stopper (option)	2

Unit:mm

Model No	Shaft diameter d1	L	B	H	b	h	B1	H1	P	X	Y	Z	Bearing	Snap ring	Weight (Kgs)
					±0.02	±0.02									
LF08	6	16	62	31	31	15.5	30	25.5	46	9	14	12.5	606ZZ	S 06	0.19
LF12	10	20	70	38	35	20	36	30	52	9	14	10	600ZZ	S 10	0.37
LF15	15	20	80	42	40	22	41	32	60	9	14	11	6002ZZ	S 15	0.35

LFA

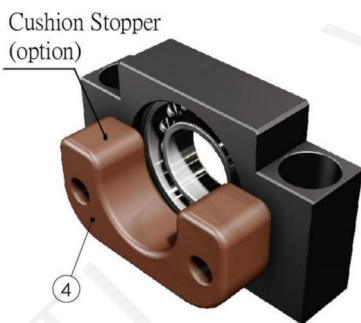

4

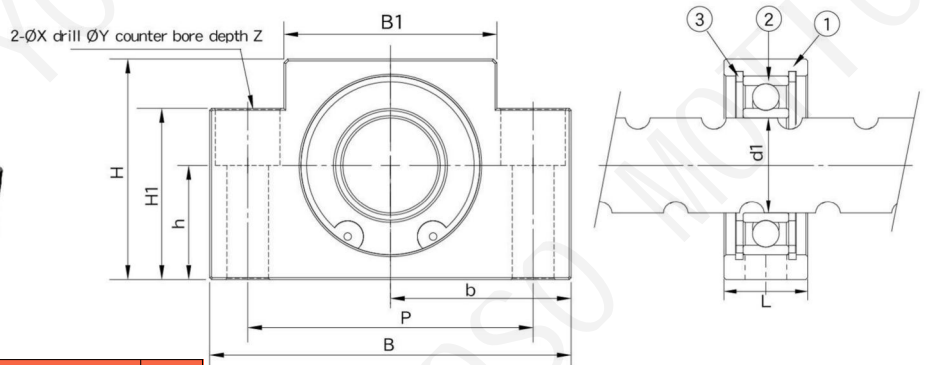

No.	Part name	Qty
1	Housing	1
2	Bearing	1set
3	Snap ring	2
4	Cushion Stopper (option)	1

Unit:mm

Model No	Shaft diameter d1	L	B	H	b	h	B1	H1	P	X	Y	Z	Bearing	Snap ring	Weight (kgs)
					±0.02	±0.02									
LFA12	12	18	62	31	31	15.5	30	25.5	46	9	14	12.5	6801ZZ	R21	0.2
LFA15	15	18	70	38	35	20	36	30	52	9	14	10	6902ZZ	R28	0.26
LFA20	20	22	80	42	40	22	41	32	60	11	17	13	6804ZZ	R32	0.35
LFA25	25	22	96	58	47.5	30	56	45	75	11	17	15	6005ZZ	R47	0.61

■ Low Profile Support Unit LF / LFA(supported side rectangular type)

Order Coding	Model No.	Surface treatment	Applicable ballscrew accuracy grade	Bearing	Delivery date	
LF08_C3	LF08	Black Oxide	C3~C7	606ZZ	EX-STOCK	 Black oxide (Application;General case)
LF08_C3N		Electroless Nickel Plating	C3~C7	606VV	3 days	
LF12_C3	LF12	Black Oxide	C3~C7	6000ZZ	EX-STOCK	
LF12_C3N		Electroless Nickel Plating	C3~C7	6000VV	EX-STOCK	
LF15_C3	LF15	Black Oxide	C3~C7	6002ZZ	EX-STOCK	
LF15_C3N		Electroless Nickel Plating	C3~C7	6002VV	3 days	
LFA12_C3	LFA12	Black Oxide	C3~C7	6801ZZ	EX-STOCK	 Electroless Nickel Plating (Application:Cleanroom)
LFA12_C3N		Electroless Nickel Plating	C3~C7	6801ZZ	3 days	
LFA15_C3	LFA15	Black Oxide	C3~C7	6902ZZ	EX-STOCK	
LFA15_C3N		Electroless Nickel Plating	C3~C7	6902ZZ	3 days	
LFA20_C3	LFA20	Black Oxide	C3~C7	6804ZZ	EX-STOCK	
LFA20_C3N		Electroless Nickel Plating	C3~C7	6804ZZ	3 days	
LFA25_C3	LFA25	Black Oxide	C3~C7	6005ZZ	EX-STOCK	
LFA25_C3N		Electroless Nickel Plating	C3~C7	6005ZZ	3 days	

Note:

1.All of bearings use Japanese & Taiwanese brand bearings .

WBk type support Unit (heavy-load)

■ WBk type support Unit (heavy-load)

No.	Part name	Qty
1	Housing	1
2	Bearing	1set
3	Holding lid	1
4	Collar	2
5	Seal	2
6	Lock nut	1set



WBK

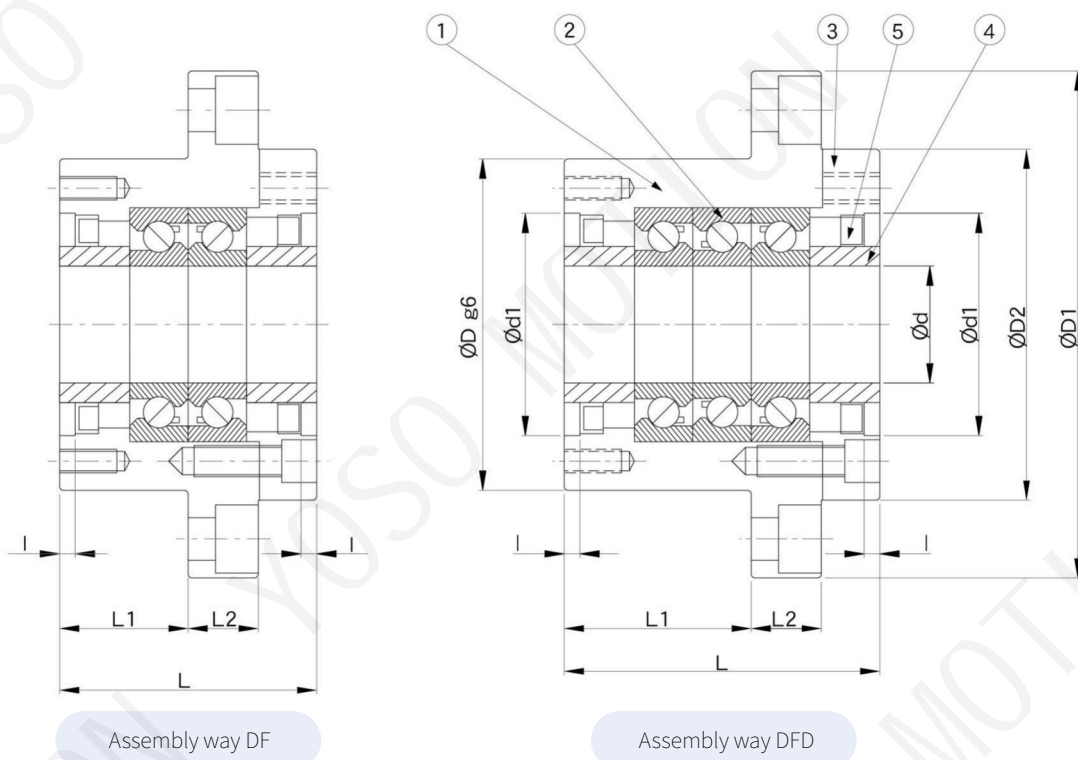

Unit:mm

Model No.	Dimensions of support unit																	
	d	D	D1	D2	L	L1	L2	A	W	X	Y	Z	d1	I	V	P	Q	H
WBK 17DF	17	70	106	72	60	32	15	80	88	9	14	8.5	45	3	58	M5	10	M6
WBK 20DF	20	70	106	72	60	32	15	80	88	9	14	8.5	5	3	58	M5	10	M6
WBK 25DF	25	85	130	90	66	33	10	100	110	11	17	11	57	4	70	M6	12	M6
WBK 25DFD					81	48												
WBK 25DFF					96	48												
WBK 30DF	30	85	130	90	66	33	18	100	110	11	17	11	57	4	70	M6	12	M6
WBK 30DFD					81	48												
WBK 30DFF					96	48												
WBK 35DF	35	95	142	102	66	33	10	106	121	11	17	11	69	4	80	M6	12	M6
WBK 35DFD					81	48												
WBK 35DFF					96	48												
WBK 40DF	40	95	142	102	66	33	18	106	121	11	17	11	69	4	80	M6	12	M6
WBK 40DFD					81	48												
WBK 40DFF					96	48												

Note:

1. Inside bearings use Japanese & Taiwanese P4 grade TAC 60 degree contact ball bearing
2. The standard type is without H, if required, please advise in advance

■ WBK type support Unit (heavy-load)

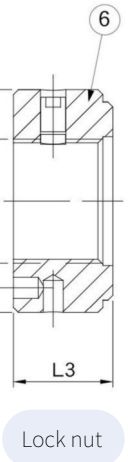
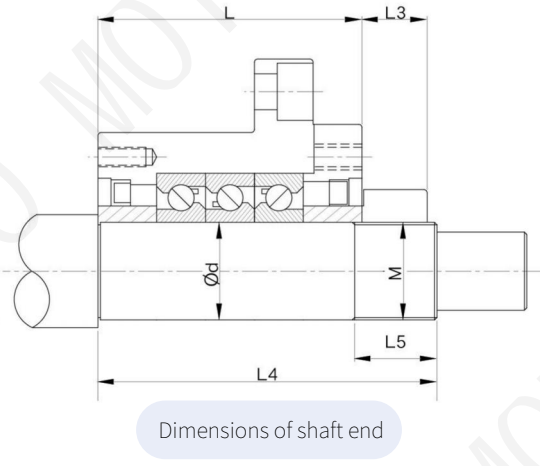
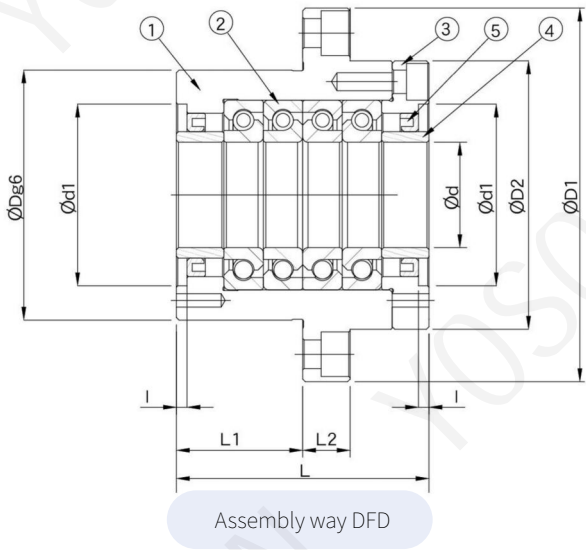
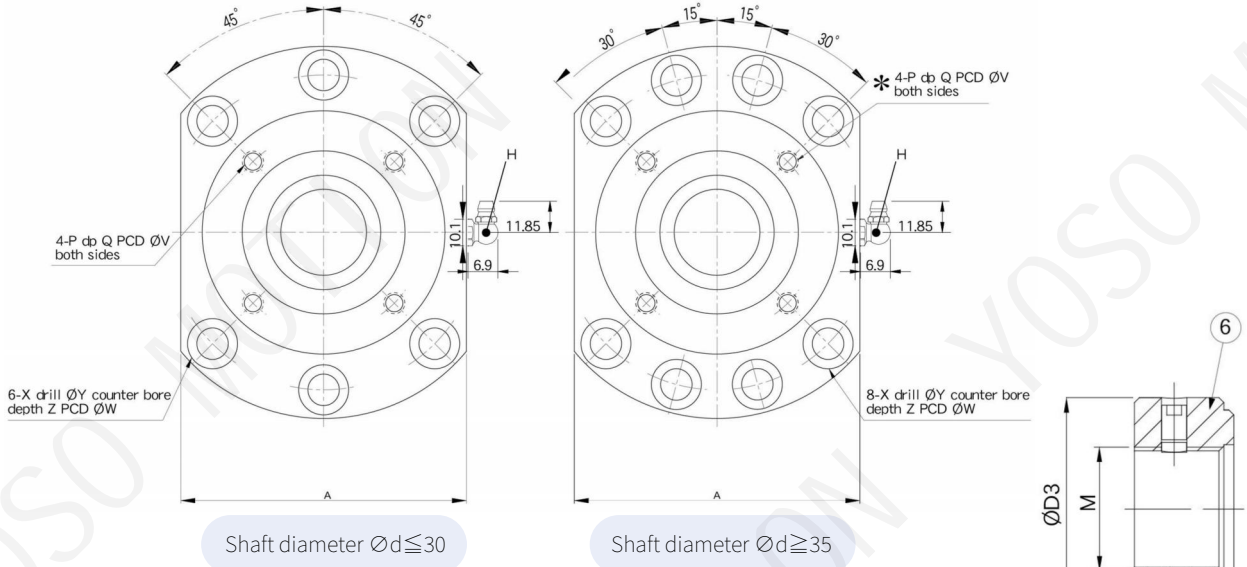

Unit:mm

Model No.	Basic dynamic load rating Ca(N)	limiting axial load (N)	preload (N)	axial rigidity (N/ μ m)	starting torque (N·cm)	permissible rotational speed (min ⁻¹)	Lock nut			Weight (Kgs)	Dimensions of shaft end			
							M	3	L3		d	L4	L5	
WBK 17DF	23000	26600	1450	630	19	6900	M17X1	36	18	2	17	-0.004 -0.017	81	09 25
WBK 20DF	23000	26600	1450	630	19	6900	M20X1	40	18	2	20	-0.005 -0.020	81	23
WBK 25DF	29900	40500	2280	850	28	5200	M25X1.5	45	20	3.27	25	-0.005 -0.020	89	26
WBK 25DFD	48500	81500	3100	1250	39					3.81			104	
WBK 25DFF	48500	81500	4500	1680	49					4.46			119	
WBK 30DF	30500	43000	2400	890	29	4900	M30X1.5	50	20	3.18	30	-0.005 -0.020	89	26 20
WBK 30DFD	50000	86000	3260	1310	39					3.7			104	
WBK 30DFF	50000	86000	4750	1760	51					4.3			119	
WBK 35DF	32500	50000	2750	1030	33	4100	M35X1.5	55	22	3.79	35	-0.006 -0.025	00 92	30
WBK 35DFD	53000	100000	3740	1500	41					4.45			107	
WBK 35DFF	53000	100000	5490	2060	52					5.21			122	
WBK 40DF	33500	52000	2860	1080	34	4100	M40X1.5	60	22	3.65	40	-0.006 -0.025	92	30
WBK 40DFD	54000	104000	3900	1590	43					4.27			107	
WBK 40DFF	54000	104000	5730	2150	55					5			122	

Note:

1. Dimensions with mark can be used for dust cover and damper installation.
About its correct position, please contact SYK.

SBK type support Unit (heavy-load)

■ SBK type support Unit (heavy-load)

No.	Part name	Qty
1	Housing	1
2	Bearing	1set
3	Holding lid	1
4	Collar	2
5	Seal	2
6	Lock nut	1set

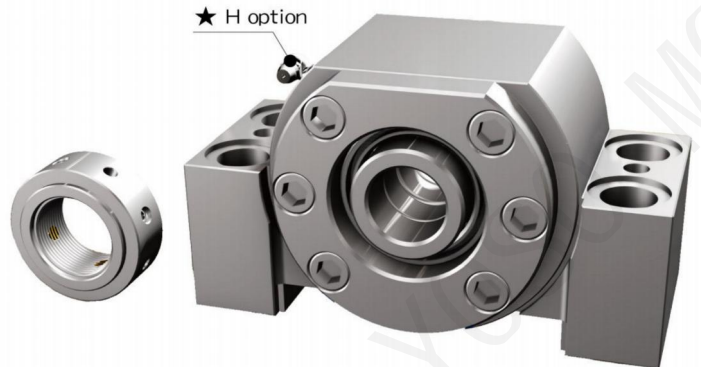

SBK

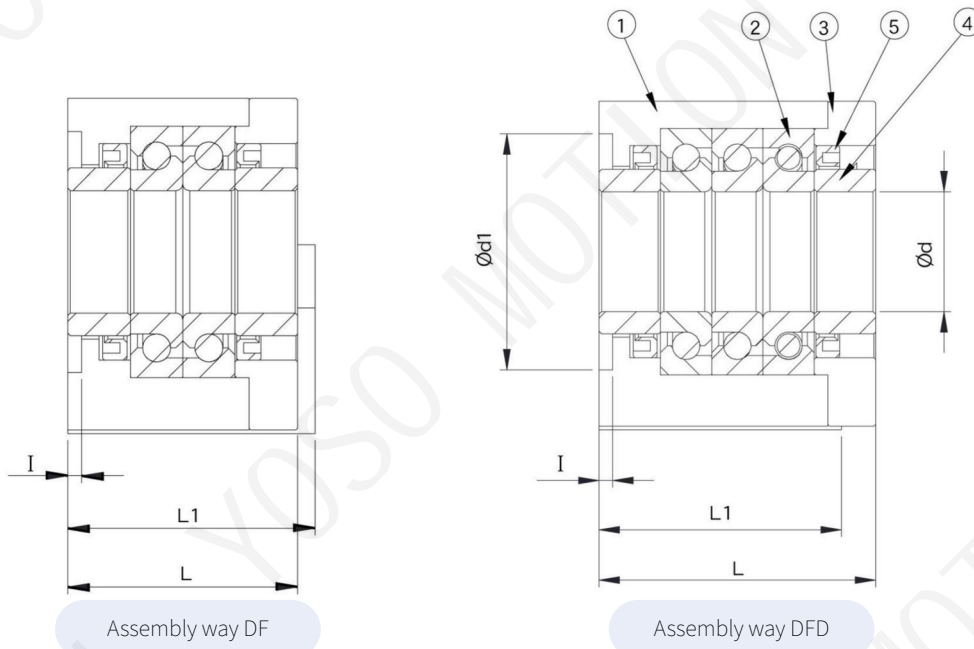

Unit:mm

Model No.	Dimensions of support unit																			Supporte side		
	d	A	$h_{\pm 0.02}$	H1	L	L1	L3	3	d1	E	C2	C1	X	Y	Z	I	V	P	Q		H	
SBK 25DF	25	89	51	53	66	71	18	160	57	130	15.5	40	18	26	2	4	70	M6	10	M6	SF25	
SBK 25DFD					81																	
SBK 30DF	30	89	51	53	66	71	18	160	57	130	15.5	40	0	10	26	2	4	70	M6	10	M6	BF30
SBK 30DFD					81																	
SBK 35DF	35	06 90	52	54	66	71	18	160	69	130	15.5	40	18	26	2	4	80	M6	10	M6	BF35	
SBK 35DFD					81																	
SBK 40DF	40	96	52	54	66	71	18	160	69	130	15.5	40	18	26	2	4	80	M6	10	M6	SF40	
SBK 40DFD					81																	

Note :

- 1.Inside bearings use Japanese & Taiwanese P4 grade TAC 60 degree contact ball bearing.
- 2.The standard type is without H,if required,please advise in advance.

■ SBK type support Unit (heavy-load)



DF

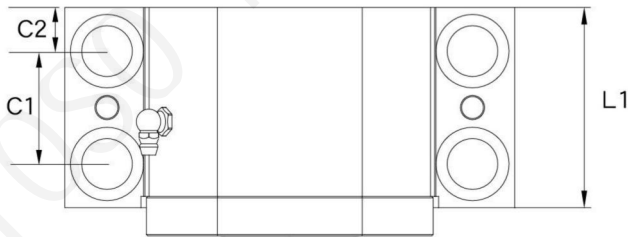

DFD

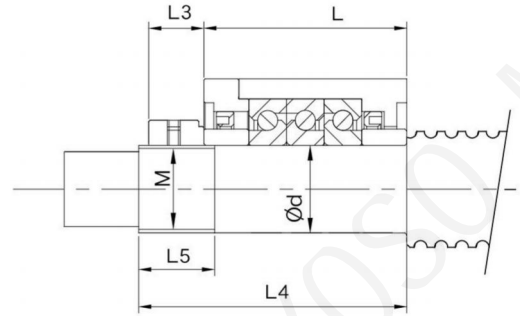

Dimensions of shaft end

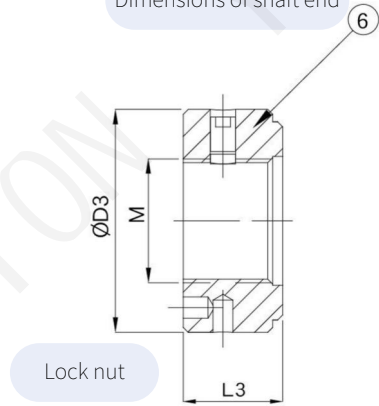

Lock nut

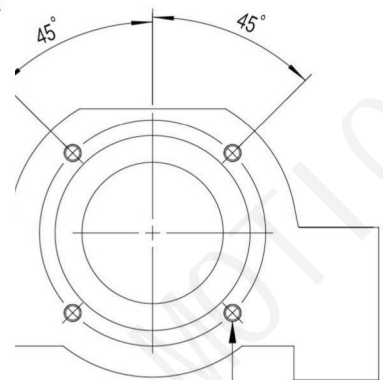
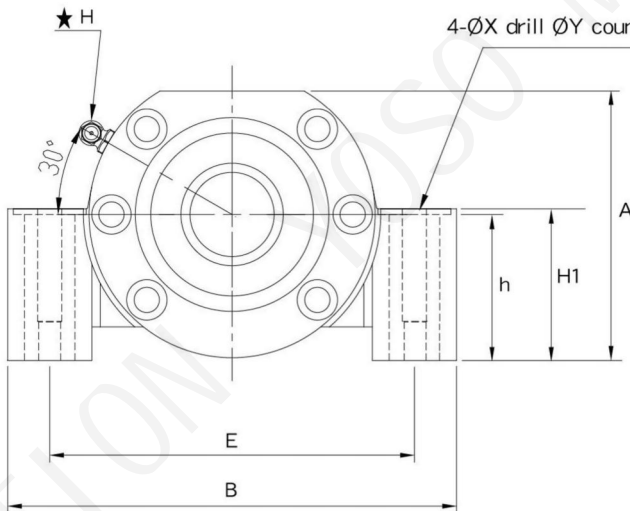

4-P ØQ PCD ØV
both sides

Unit:mm

Model No.	Basic dynamic load rating Ca(N)	limiting axial load (N)	preload (N)	axial rigidity (N/µm)	starting torque (N · cm)	permissible rotational speed	Lock nut		Weight (Kgs)	Dimensions of shaft end			
							M	L3		d	L4	L5	
SBK 25DF	29900	40500	2280	850	28	5200	M25X1.5	45	20	4.46	25 ^{-0.005 -0.020}	89	26
SBK 25DFD	48500	81500	3100	1250	39					5.25		104	
SBK 30DF	30500	43000	2400	890	29	4900	M30X1.5	50	20	4.35	30 ^{-0.005 -0.020}	89	26
SBK 30DFD	50000	86000	3260	1310	39					5.09		104	
SBK 35DF	32500	50000	2750	1030	33	4100	M35X1.5	55	22	4.57	35 ^{-0.006 -0.020}	92	30
SBK 35DFD	53000	100000	3740	1500	41					5.3		107	
SBK 40DF	33500	52000	2860	1080	34	4100	M40X1.5	60	22	4.6	40 ^{-0.006 -0.020}	92	30
SBK 40DFD	54000	104000	3900	1590	43					5.15		107	

MBK type support Unit (Heavy-load)

■ MBK type support Unit (Heavy-load)

No.	Part name	Qty
1	Housing	1
2	Bearing	1set
3	Holding lid	1
4	Collar	2
5	Seal	2
6	Lock nut	1set



MBK

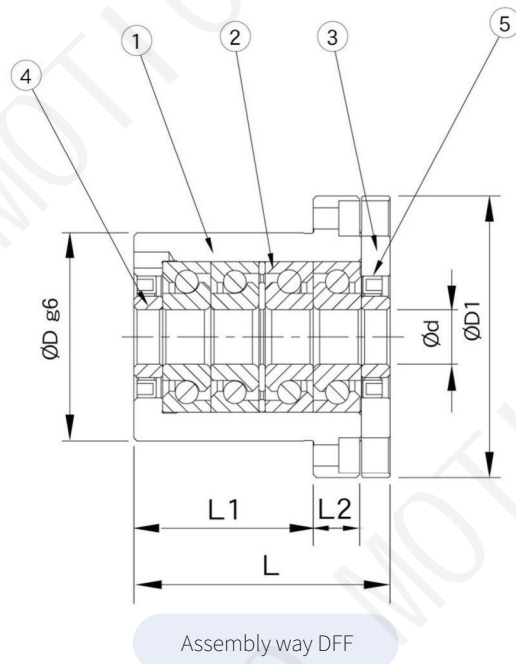
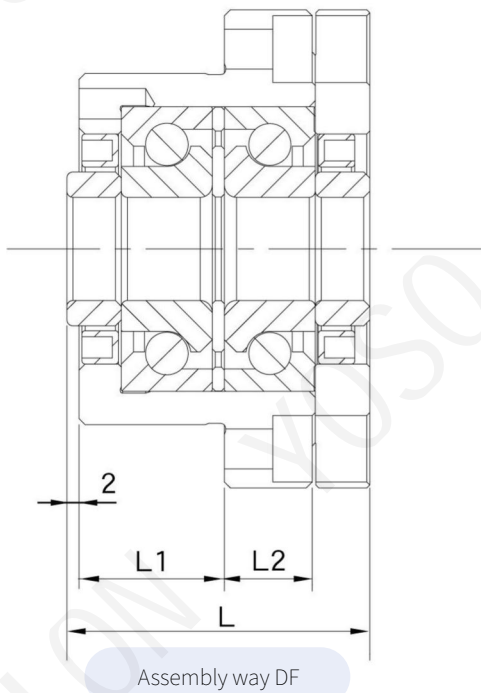

Unit:mm

Model No.	Dimensions of support unit											
	d	D	D1	L	L1	L2	A	W	X	Y	Z	H
MBK 15DF -G	15	58	79	50	24	14.5	79	66	6.6	11	7	M6
MBK 17DF -G	17	58	79	50	24	14.5	79	66	6.6	11	7	M6
MBK 17DFF -G		65	88	80	56		88	74				
MBK 20DF -G	20	58	79	50	24	14.5	79	A6	6.6	11	7	M6
MBK 20DFF -G		65	88	80	56		88	74				

■ Support Unit MBK (fixed-side round type)

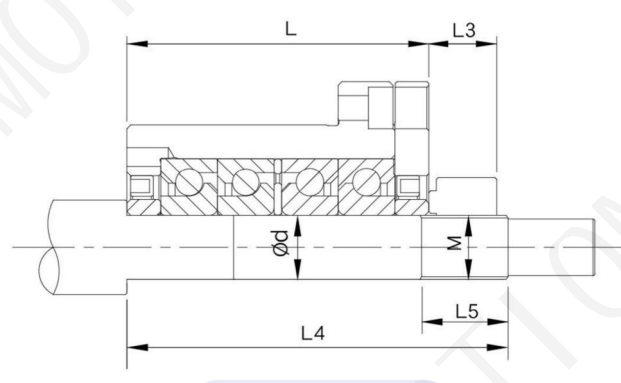
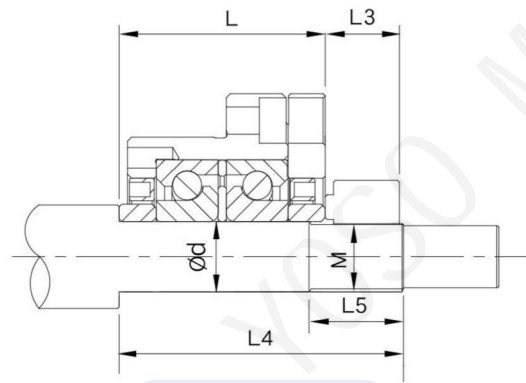
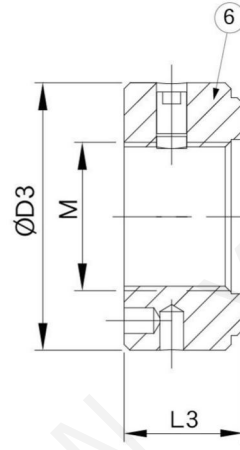
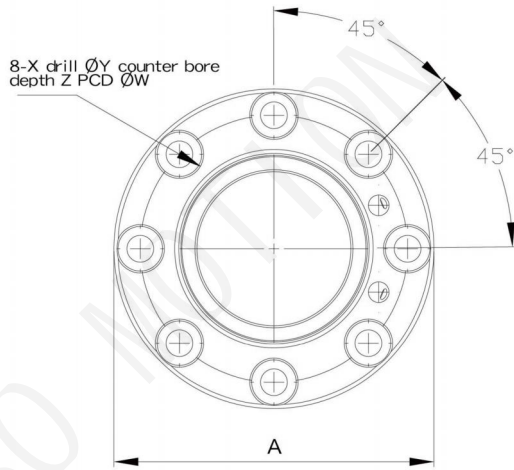

Unit:mm

Model No	Basic dynamic load rating Ca(N)	limiting axial load (N)	preload (N)	axial rigidity (N/ μ m)	starting torque (N · cm)	permissible rotational speed (min)	Lock nut			Weight (kgs)	Dimensions of shaft end		
							M	D3	L3		d	L4	L5
MBK 15DF	21900	26600	1000	555	19	7600	M15X1	—	—	1.44	15 ^{-0.004} _{-0.017}	69	23
MBK 17DF	23000	26600	1450	630	19	6900	M17X1	37	18	1.55	17 ^{-0.004} _{-0.017}	69	23
MBK 17DFF	47500	53500	2010	920	32					2.3		101	
MBK 20DF	23000	26600	1450	630	19	6900	M20X1	40	18	1.52	20 ^{-0.005} _{-0.020}	69	23
MBK 20DFF	47500	53500	2010	920	32					2.78		101	

Lock Nut

■ Lock nut



No.	Part name	Qty
1	Lock nut	1 set

Lock Nut

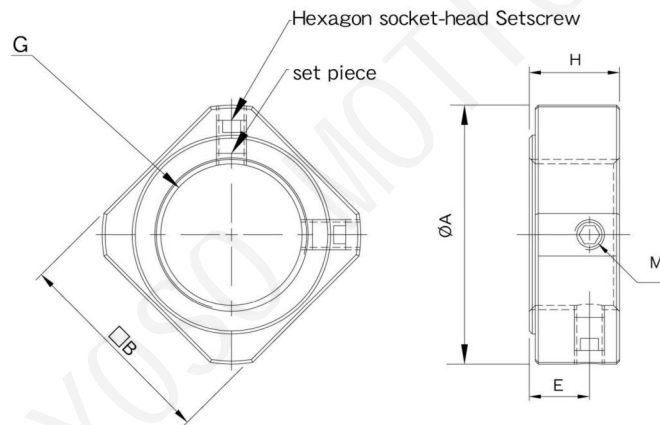

Unit:mm

Unit:mm

Model No.	H	A	E	M	B	G
RN05 RN05_N	5	12.5	2.7	M3x0.5	11	M5×0.5
RN06 RN06_N	5	13.5	2.7	M3x0.5	12	M6x0.75
RN08 RN08_N	6.5	16.4	4	M3x0.5	14	M8x1.0
RN10 RN10_N	8	19	5.5	M3x0.5	16	M10x1.0
RN12 RN12_N	8	22.8	5.5	M4x0.7	19	M12x1.0
RN15 RN15_N	8	25.8	4.75	M4x0.7	22	M15x1.0

Model No.	H	A	E	M	B	G
RN17 RN17_N	13	29	9	M4	24	M17×1.0
RN20 RN20_N	11	35	7	M4	30	M20x1.0
RN25 RN25_N	15	43	10	M6	35	M25x1.5
RN30 RN30_N	20	48	14	M6	40	M30x1.5
RN35 RN35_N	21	60	14	M6	50	M35x1.5
RN40 RN40_N	25	62	18	M6	50	M40x1.5

■ Lock nut(Heavy-load)



No.	Part name	Qty
1	Lock nut	1set

Lock Nut (Heavy-load)

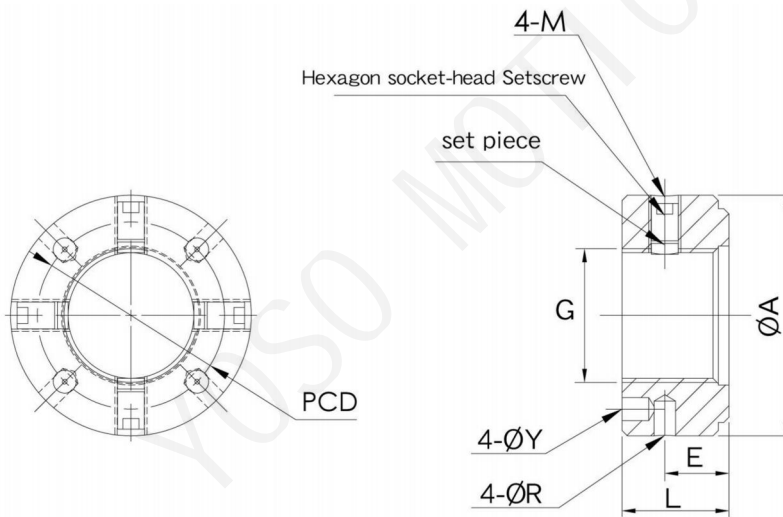

SPANNER

Unit:mm

Model No.	L	E	A	M	Y	R	PCD	G	SPANNER
RN17W RN17W_N	18	10	36	M6	4.3	4	27	M17×1.0	ZL017
RN20W RN20W_N	18	10	40	M6	4.3	4	30	M20x1.0	ZL020
RN25W RN25W_N	20	11	45	M6	4.3	5	35	M25×1.5	ZL025
RN30W RN30W_N	20	11	50	M6	4.3	5	40	M30x1.5	ZL025
RN35W RN35W_N	22	12	55	M6	4.3	5	45	M35x1.5	ZL035
RN40W RN40W_N	22	12	60	M6	4.3	5	50	M40x1.5	ZL040

Lock Nut

■ Lock nut

Order Coding	Model No.	Surface treatment	MAX.Torque (kgf-cm)	Setscrew MAX.Torque (kgf-cm)	
RN05	M5*P0.5	Black Oxide	15	6(M3)	 <p>Black oxide (Application;General case)</p>
RN05_N		Electroless Nickel Plating			
RN06	M6*P0.75	Black Oxide	20	6(M3)	
RN06_N		Electroless Nickel Plating			
RN08	M8*P1.0	Black Oxide	25	6(M3)	
RN08_N		Electroless Nickel Plating			
RN10	M10*P1.0	Black Oxide	30	6(M3)	
RN10_N		Electroless Nickel Plating			
RN12	M12*P1.0	Black Oxide	65	15(M4)	 <p>Electroless Nickel Plating (Application:Cleanroom)</p>
RN12_N		Electroless Nickel Plating			
RN15	M15*P1.0	Black Oxide	80	15(M4)	
RN15_N		Electroless Nickel Plating			
RN17	M17*P1.0	Black Oxide	95	15(M4)	
RN17_N		Electroless Nickel Plating			
RN17W	M17*P1.0 (Heavy-load)	Black Oxide	420	50(M6)	
RN17W_N		Electroless Nickel Plating			
RN20	M20*P1.0	Black Oxide	170	15(M4)	 <p>Heavy-load</p>
RN20_N		Electroless Nickel Plating			
RN20W	M20*P1.0 (Heavy-load)	Black Oxide	460	50(M6)	
RN20W_N		Electroless Nickel Plating			
RN25	M25*P1.5	Black Oxide	210	50(M6)	
RN25_N		Electroless Nickel Plating			
RN25W	M25*P1.5 (Heavy-load)	Black Oxide	870	50(M6)	
RN25W_N		Electroless Nickel Plating			
RN30	M30*P1.5	Black Oxide	320	50(M6)	 <p>Black oxide (Application;General case)</p>
RN30_N		Electroless Nickel Plating			
RN30W	M30*P1.5 (Heavy-load)	Black Oxide	1050	50(M6)	
RN30W_N		Electroless Nickel Plating			
RN35	M35*P1.5	Black Oxide	480	50(M6)	
RN35_N		Electroless Nickel Plating			
RN35W	M35*P1.5 (Heavy-load)	Black Oxide	1450	50(M6)	
RN35W_N		Electroless Nickel Plating			
RN40	M40*P1.5	Black Oxide	720	50(M6)	 <p>Electroless Nickel Plating (Application:Cleanroom)</p>
RN40_N		Electroless Nickel Plating			
RN40W	M40*P1.5 (Heavy-load)	Black Oxide	1600	50(M6)	
RN40W_N		Electroless Nickel Plating			

■ Recommended shaft end shape (Fixed-side) for Support Units types BK

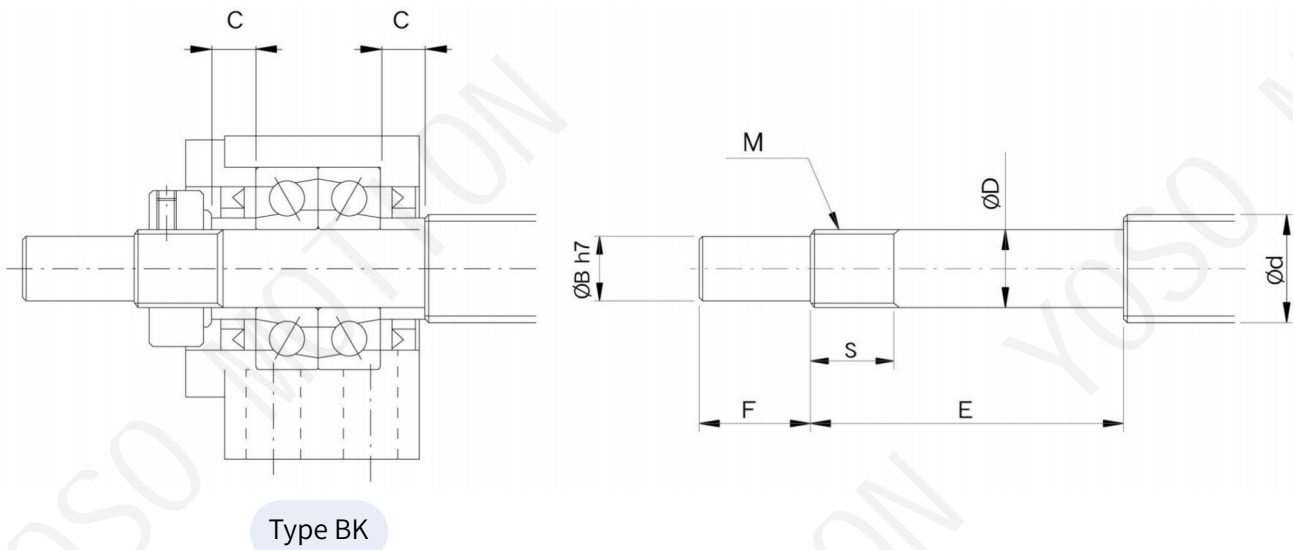

Unit:mm

Support unit model No.	Ballscrew shaft OD	Shaft support portion OD				Metric screw thread	Length of Sleeve	
Type BK	d	D	B	E	F	M	S	C
BK10	12/14/15	10 -0.008 -0.015	8	36	15	M10×1	12	5.5
BK12	14/15/16	12 -0.008 -0.017	10	36	15	M12×1	12	5.5
BK15	18/20	15 -0.008 -0.017	12	40	20	M15×1	12	6
BK17	20/25	17 -0.008 -0.017	15	53	23	M17×1	17	7
BK20	25/28	20 -0.010 -0.020	17	53	25	M20×1	15	8
BK25	32/36	25 -0.010 -0.020	20	66	30	M25×1.5	20	9
BK30	36/40	30 -0.010 -0.020	25	73	38	M30×1.5	25	9
BK35	45	35 -0.012 -0.025	30	82	45	M35×1.5	26	12
BK40	50	40 -0.012 -0.025	35	94	50	M40×1.5	30	15

Recommended shaft end shape(Fixed-side)

■ Support Units types FK,FKA,EK,AK,LK

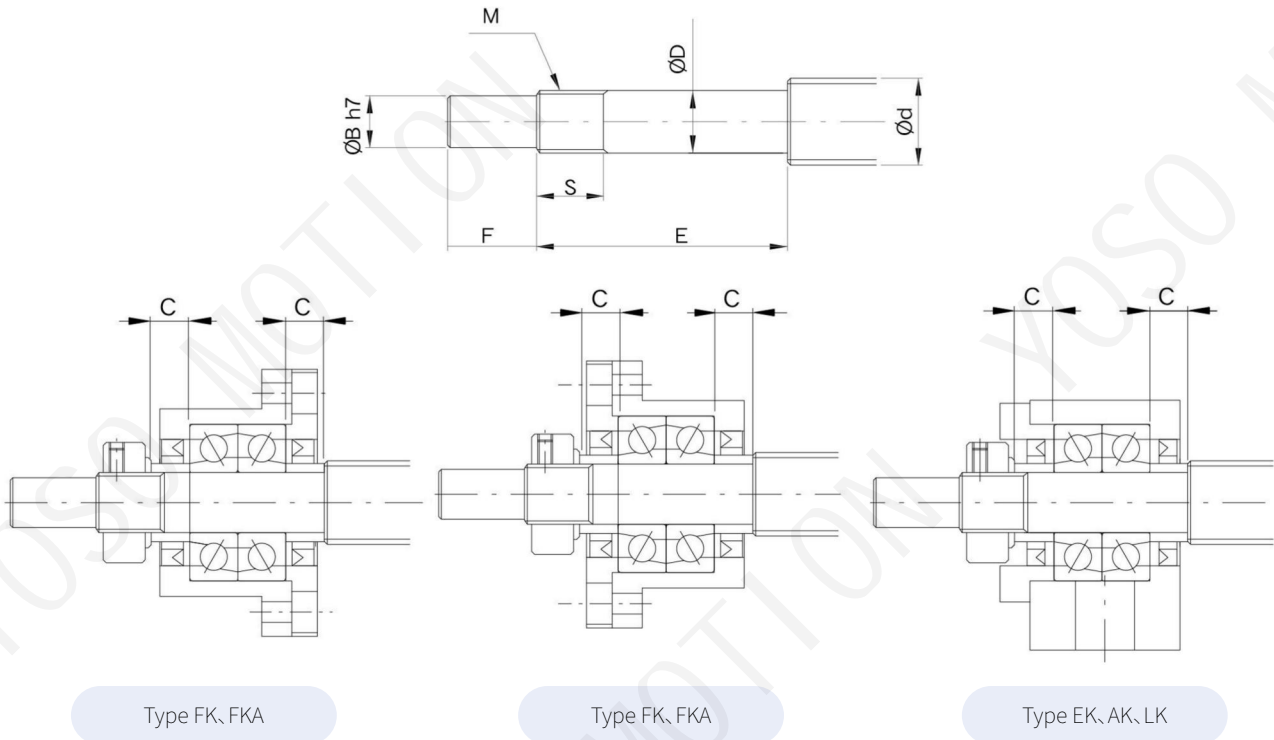

Unit:mm

Support unit model No.				Ballscrew shaft OD	Shaft support portion OD			Metric screw thread			Length of Sleeve	
Type FK,FKA	Type EK	Type AK	Type LK	d	D		B	E	F	M	S	C
FK05	EK05	-	-	8	5	-0.008 -0.015	4	23	6	M5x0.5	7	3.5
FK06 FKA06	EK06	-	-	8	6	-0.008 -0.015	4	28	8	M6x0.75	8	5
FK08 FKA08	EK08	-	LK08	10/12	8	-0.008 -0.015	6	32	9	M8x1	10	5.5
FK10 FKA10	EK10	AK10	LK10	12/14/15	10	-0.008 -0.015	8	36	15	M10x1	12	5.5
FK12 FKA12	EK12	AK12	LK12	14/15/16	12	-0.008 -0.017	10	36	15	M12x1	12	5.5
FK15 FKA15	EK15	AK15	LK15	18/20	15	-0.008 -0.017	12	48	20	M15x1	13	10
FKA15H												6
FK17	-	-	-	20/25	17	-0.008 -0.017	15	59	23	M17x1	17	10
FK20 FKA20	EK20	AK20	-	25/28/30	20	-0.010 -0.020	17	64	25	M20x1	16	11
FKA20L								53			15	8
FK25	-	AK25	-	30/32/36	25	-0.010 -0.020	20	76	30	M25x1.5	20	14
FK30	-	-	-	36/40	30	-0.010 -0.020	25	73	38	M30x1.5	25	9

■ Recommended shaft end shape(Supported-side) for Support Units types FF,EF,BF,AF,LF

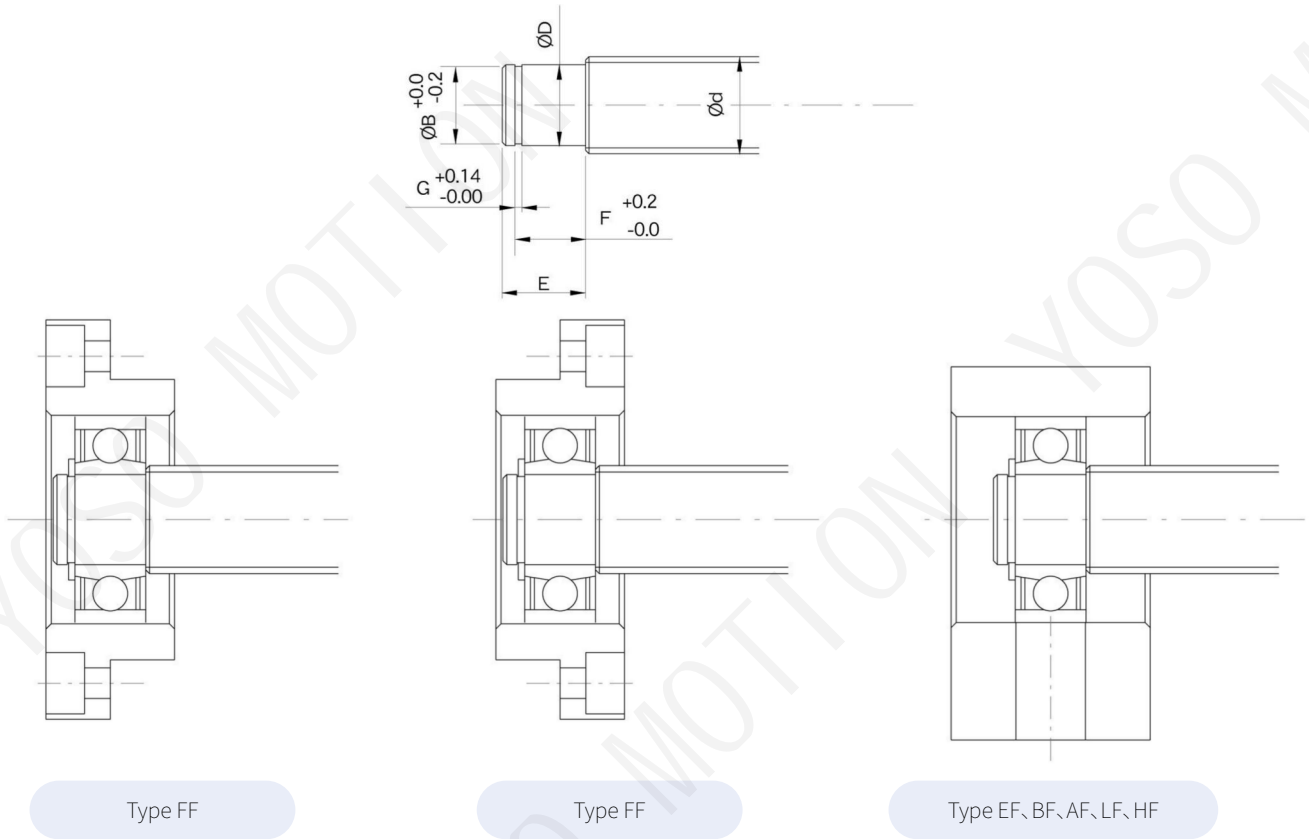

Unit:mm

Support unit model No.					Ballscrew shaft OD	Shaft support portion OD				
Type FF	Type EF	Type BF	Type AF	Type LF	d	D	E	B	F	G
FF06	EF06	—	—	—	8	6 -0.008 -0.015	9	5.7	6.8	0.8
—	EF08	—	—	LF08	10	6 -0.008 -0.015	9	5.7	6.8	0.8
FF10	EF10	BF10	AF10	—	12/14/15	8 -0.008 -0.015	10	7.6	7.9	0.9
FF12	EF12	BF12	AF12	LF12	14/15/16	10 -0.008 -0.015	11	9.6	9.15	1.15
FF15	EF15	BF15	AF15	LF15	18/20	15 -0.008 -0.017	13	14.3	10.15	1.15
FF17	—	BF17	—	—	20/25	17 -0.008 -0.017	16	16.2	13.15	1.15
—	—	BF20	—	—	25/28/30	20 -0.010 -0.020	16	19	13.35	1.35
FF20	EF20	—	AF20	—			19		15.35	
FF25	—	BF25	AF25	—	30/32/36	25 -0.010 -0.020	20	23.9	16.35	1.35
FF30	—	BF30	—	—	36/40	30 -0.010 -0.020	21	28.6	17.75	1.75
—	—	BF35	—	—	40/45	35 -0.012 -0.025	22	33	18.75	1.75
—	—	BF40	—	—	50	40 -0.012 -0.025	23	38	19.95	1.95

Recommended shaft end shape (Heavy-load)

■ Recommended shaft end shape (Heavy-load)

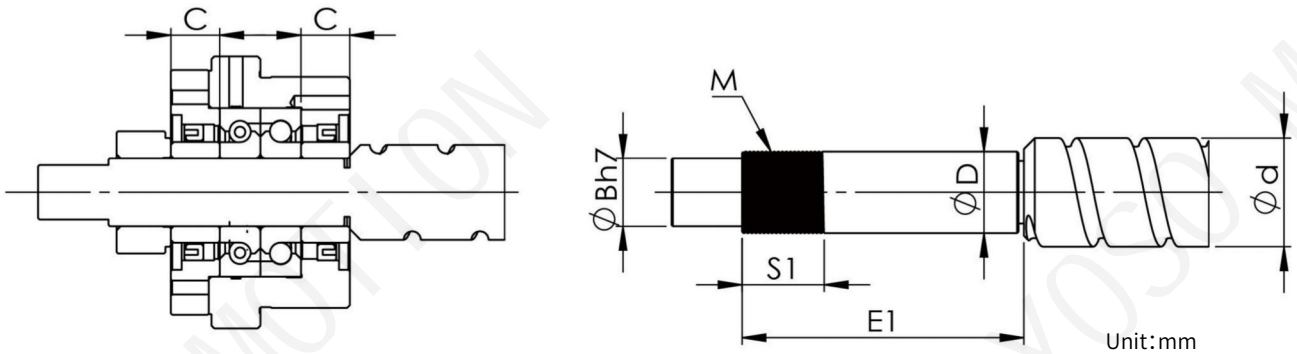

model No.	Ballscrew shaft OD	Shaft support portion OD		B	E1	Metric screw thread		Length of Sleeve
	d	D				M	S1	
WBK17 DF	20/25	17	-0.004 -0.017	15	81	M17x1	23	15
WBK20 DF	25/28	20	-0.005 -0.02	17		M20x1		
WBK25 DF	32/36	25	-0.005 -0.020	20	89	M25x1.5	26	18
WBK25 DFD					104			
WBK25 DFF					119			
WBK30 DF	36/40	30	-0.005 -0.020	25	89	M30x1.5	26	18
WBK30 DFD					104			
WBK30 DFF					119			
WBK35 DF	45	35	-0.006 -0.025	30	92	M35x1.5	30	18
WBK35 DFD					107			
WBK35 DFF					122			
WBK40 DF	50	40	-0.006 -0.025	35	92	M40x1.5	30	18
WBK40 DFD					107			
WBK40 DFF					122			
MBK15 DF	18/20	15	-0.004 -0.017	12	69	M15x1	23	9
MBK17 DF	20/25	17	-0.004 -0.017	15		M17x1		
MBK17 DFF					101			
MBK20 DF	25/28	20	-0.005 -0.020	17	69	M20x1	23	9
MBK20 DFF					101			
SBK25 DF	32/36	25	-0.005 -0.020	20	89	M25x1.5	26	18
SBK25 DFD					104			
SBK30 DF	36/40	30	-0.005 -0.020	25	89	M30x1.5	26	18
SBK30 DFD					104			
SBK35 DF	45	35	-0.006 -0.025	30	92	M35x1.5	30	18
SBK35 DFD					107			
SBK40 DF	50	40	-0.006 -0.025	35	92	M40x1.5	30	18
SBK40 DFD					107			

■ Ballscrew support unit equivalent interchangeable for major manufacturer

SYK&T*K
BK10
BK12
BK15
BK17
BK20
BK25
BK30
BK35
BK40
BF10
BF12
BF15
BF17
BF20
BF25
BF30
BF35
BF40

SYK&THK	KURODA	NSK	MISUMI
EK05	—	—	—
EK06	BUK-6	WBK06-01A	BSW06
EK08	BUK-8F	WBK08-01A	BSW08
EK10	—	—	—
EK12	—	—	—
EK15	—	—	—
EK20	—	—	—
EF06	—	—	BUN06
EF08	BUK-6S	WBK08S-01	BUN08
EF10	—	—	BUN10
EF12	—	—	BUN12
EF15	—	—	—
EF20	—	—	BUN20

SYK&THK	KURODA	NSK	MISUMI
FK05	—	—	—
FK06	—	WBK06-11	BRW06
FK08	BUM-8	WBK08-11	BRW08
FK10	BUM-10	WBK10-11	BRW10
FK12	BUM-12	WBK12-11	BRW12
FK15	BUM-15	WBK15-11	BRW15
FK17	—	—	—
FK20	BUM-20	WBK20-11	BRW20
FK25	BUM-25	WBK25-11	BRW25
FK30	—	—	—
FF06	—	—	BUR06
FF10	—	—	BUR10
FF12	—	—	BUR12
FF15	—	—	BUR15
FF17	—	—	—
FF20	—	—	BUR20
FF25	—	—	BUR25
FF30	—	—	—

SYK	KURODA	NSK	MISUMI
AK10	BUK-10F	WBK10-01A	BSW10
AK12	BUK-12F	WBK12-01A	BSW12
AK15	BUK-15F	WBK15-01A	BSW15
BK17	—	WBK17-01A	—
AK20	BUK-20F	WBK20-01	BSW20
AK25	BUK-25F	WBK25-01	BSW25
AF10	BUK-8S	WBK10S-01	—
AF12	BUK-10S	WBK12S-01	—
AF15	BUK-15S	WBK15S-01	—
BF17	—	WBK17S-01	—
AF20	BUK-20S	WBK20S-01	—
AF25	BUK-25S	WBK25S-01	BUN25

SYK	NSK
WBK 17DF	WBK 17DF-31
WBK 20DF	WBK 20DF-31
WBK 25DF	WBK 25DF-31
WBK 25DFD	WBK 25DFD-31
WBK 30DF	WBK 30DF-31
WBK 30DFD	WBK 30DFD-31
WBK 35DF	WBK 35DF-31
WBK 35DFD	WBK 35DFD-31
WBK 40DF	WBK 40DF-31
WBK 40DFD	WBK 40DFD-31

SYK	NSK	PMI
LK08	WBK08-01B	—
LK10	WBK10-01B	—
LK12	WBK12-01B	PBKN12
LK15	WBK15-01B	PBKN15
AK20	WBK20-01	PBKN20
LF08	WBK08S-01B	—
LF12	WBK12S-01B	—
LF15	WBK15S-01B	—
LFA12	WBK12SF-01	PBFN12
LFA15	WBK15SF-01	PBFN15
LFA20	WBK20SF-01	PBFN20
LFA25	WBK25SF-01	PBFN25

Nut Bracket MC

■ Nut Bracket MC



MC

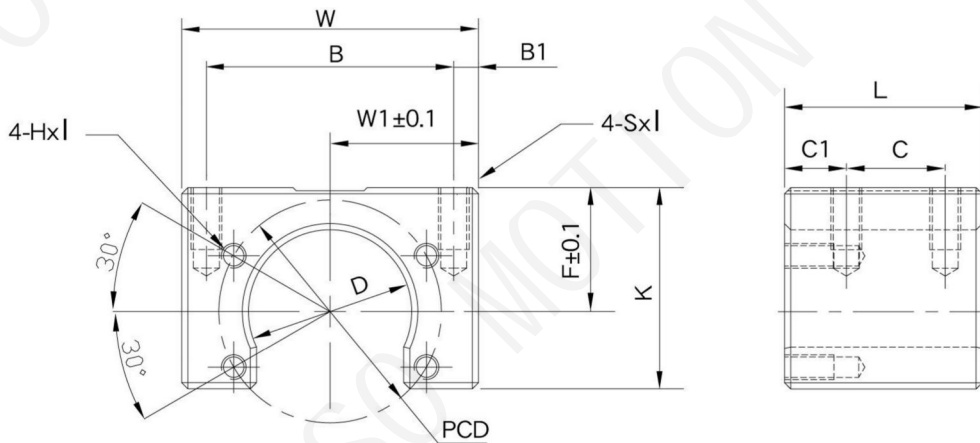

Unit:mm

Model No.	Width W	W1	B	B1	Overall Length	C	C1	F	K	D	PCD	SxI	HxI	Far factory automation equipment Supported Ball Screw models	Weight (Kgs)
MC 1004	48	24	40	4	32	16	10	20	32.5	26.4	36	M5×10	M4×7	BNK1004, BNK1005	0.24
MC 1205	60	30	47	6.5	36	24	6	21	37	30.4	40	M6×12	M4×7	BNK1205	0.38
MC 1408	60	30	50	5	36	20	10	21.5	37	34.4	45	M6×12	M5×8	BNK1408, BNK1510 BNK1520, BNK1616	0.34
MC 2010	86	43	70	8	50	30	10	31	54	46.4	59	M10×20	M6×10	BNK2010	1.04
MC 2020	86	43	70	8	40	24	8	28	51	39.4	59	M10×20	M6×10	BNK2020	0.83

Application table of MC Nut bracket for ballscrewmanufacturer.

Model NO.	Ballscrew manufacturer					
	THK	NSK	HIWIN	PMI	COMTOP	GTEN
MC 1004	BNK1004, BNK1005	W1004 FA,	R1004FSW	FSIW1404, FSIC1403 FSIC1404, FSIC1405		FSI1404, FSI1405
MC1205	BNK1205 BNK1205	W1205 FA, W1210 FA	R1205FSW, R1210FSW	FSWW1204, FSWC1204/05 FSWC1210, PTR1205/10/20	XSVR1210	FSC1210
MC 1408	BNK1408, BNK1510 BNK1520, BNK1616	W1405 FA, W1408 FA W1510 FA, W1520 FA W1616 FA, W1632 FA	R1405FSW, R1408FSW FSW1510, R1510DFSH R1520DFSH, R1520FSH, R1632DFSH	FSIC2005/06, FSWC1405 FSWC1510, FSKC1520 PTR1505/10/20	SFI 1610, SFI 2004 SFI 2005 XSVR1510, XSVR1520	FSI1610, FSI2005 FSC1520
MC 2010	BNK2010	W2010 FA, W2020 FA	R2010FSW, R2020FSW	FSWC2010, PTR2010	XSVR2010, XSVR2020	FSC2010
MC 2020	BNK2020		R 2020DFSH			

■ Nut Bracket MGD



MGD

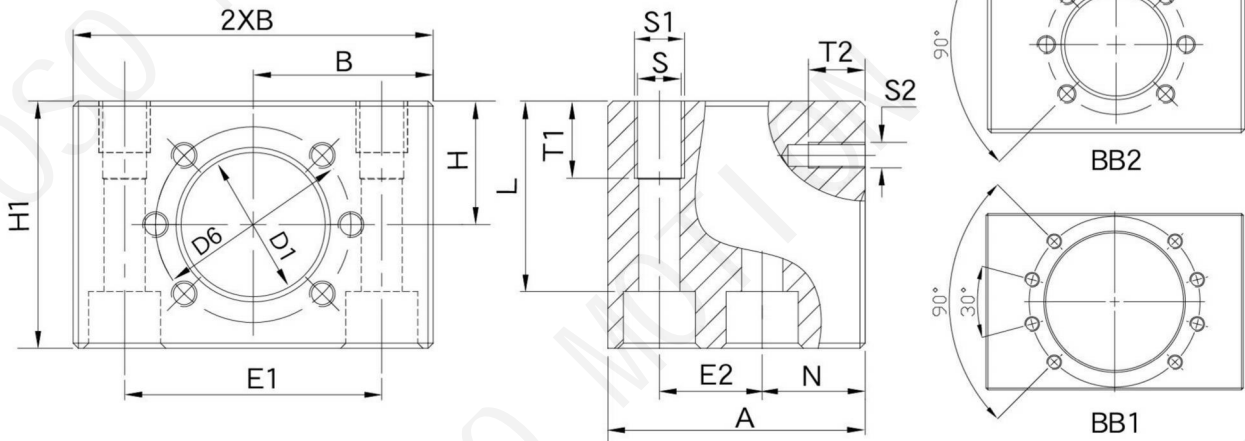

Unit:mm

Model No.	Size d ₀ × P	Part number	D1±0.1	D6	A	B±0.1	H±0.1	H1	E1	E2	N	S	S1	T	S2	T2	ISO4762	Weight (Kgs)		
MGD 16L	16×5 16×10	1506-0-0050	28.4	38	36	28	20	39	46±0.1	20±0.1	8	—	M6	12	M5	10	BB2	—	—	
MGD 16	16×16					35	24	48						15				15	M8	37
MGD 20L	20×5 20×20	1506-1-0050	36.4	47	55	37.5	23	48	55±0.1	23±0.1	22	—	M8	14	M6	11	BB2	—	—	
MGD 20														28				54	15	15
MGD 25	25×5 25×10 25×25	1506-2-0050	40.4	51	55	40	30	58	60±0.1	23±0.1	22	8.4	M10	15	M6		BB2	M8	49	1.33
MGD 32S	32×5 32×10 32×20 32×32	1506-3-0050	50.4	65	70	45	35	68	70±0.1	45±0.1	12.5	—	M12	20	M8	14	BB2	—	—	2.5
MGD 32									75±0.1	30±0.1	27	13	M16					M12	52	2.77
MGD 40	40×5 40×10 40×12 40×16 40×20 40×40	1506-4-0050	63.4	78	80	60	42	84	90±0.1	35±0.1	31	15	M18	25	M8	17	BB1	M14	66	3.61

Application table of MGD Nut bracket for ballscrew manufacturer.

Model No	Ballscrew manufacturer					
	STAR	HIWIN	PMI	COMTOP	GTEN	
MGD 16	1502,1512-0-****	FSI-16-05	FSIN-16-05	SFU 1605	FSU	1605
MGD 20	1502,1512-1-****	FSI-20-05	FSIN-20-05	SFU 2005	FSU	2005
MGD 25	1502,1512-2-****	FSI-25-05	FSIN-25-05	SFU 2505	FSU	2505
		FSI-25-10	FSIN-25-10	SFU 2510	FSU	2510
MGD 32	1502,1512-3-****	FSI-32-05	FSIN-32-05	SFU 3205	FSU	3205
		FSI-32-10	FSIN-32-10	SFU 3210	FSU	3210
MGD 40	1502,1512-4-****	FSI-40-05	FSIN-40-05	SFU 4005	FSU	4005
		FSI-40-10	FSIN-40-10	SFU 4010	FSU	4010



YOSO German quality, Industrie 4.0 best platform



High speed



Heavy load

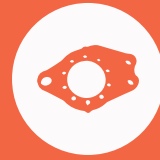

Precise

Focusing on the research and production of high-speed heavy-duty precision ball screws

Jingpeng Machinery Equipment (Shanghai) Co., Ltd.

Contact information:

☎ Telephone: 0086-13636560152

📍 Address: Room 1913, Linton Building, Jing'an District, Shanghai

🌐 Website: www.yosomove.com



Whatsapp