



YOSO
LINEAR MOTION

LINEAR
GUIDE

CONTENT — YOSO MOTION

1. Introduction to Linear Guides	A01
1-1 High Accuracy	A01
1-2 Recognizing of Master Rail.....	A01
1-3 For Butt-joint Rail.....	A02
2. YOSO Linear Guideway Product Series	A03
2-1 YG series Heavy Load Ball Type	A03
2-1-3 Model Number of YG Series	A04
2-1-13 Dimensions for YOSO YG Series	A21
2-1-13 YGH-R/YGH-LR Series Specifications.....	A21
2-1-13 YGL-R/YGL-LR Series Specifications.....	A22
2-1-13 YGH-C/YGH-LC Series Specifications.....	A23
2-2 YSR Series Low Profile Ball Type	A25
2-2-3 Model Number of YSR Series	A26
2-2-13 Dimensions for YOSO YSR Series	A38
2-2-13 YSR-R/YSR-LR Series Specifications.....	A38
2-2-13 YSR-C/YSR-LC Series Specifications.....	A39
2-3 YEH Series Four-Row Wide Rail	A40
2-3-3 Model Number of YEH Series	A41
2-3-13 YEH-R Series Specifications	A52
2-3-13 YEH-C Series Specifications	A53
2-4 YSS Series Miniature Type	A54
2-4-10 Model Number of YSS Series	A58
2-4-19 YSS-MS YSS-MN Series Specifications	A67
2-4-20 YSS-WS YSS-WN Series Specifications	A68
2-5 PGH Steel strip Linear Guide	A69
2-5-2 Nominal Model Code of PGH Type	A70
2-5-3 PGH-C/PGH-LC Series Specifications	A71
2-5-4 PGH-R/PGH-LR Series Specifications	A72
2-6 YGG series -High Rigidity Roller Type Linear Guideway	A73
2-6-3 Model Number of YGG series	A75
2-6-12 Dimensions for YGG series	A87
2-6-12 YGG-R/YGG-LR Series Specifications	A87
2-6-12 YGG-C/YGG-LC Series Specifications	A88
2-7 SE Type-Metal End Cap Linear Guideway.....	A89
2-8 Stainless Steel Linear Guideway.....	A90
2-9 YS-CSR LM GUIDE CROSS LM GUIDE MODEL.....	A91
2-9-4 Model number coding	A93
2-9-4 YS-CRS-S Series Specifications.....	A94
2-9-5 Standard Length and Maximum Length of the LM Rail.....	A96

YOSO MOTION LINEAR GUIDE RAIL

linear guide rail

■ Introduction to Linear Guides

1-1-1 High Accuracy

LinearGuide has littlefriction,onlya small driving force is needed tomovethe load.Low frictionhelps thetemperature rising effect tostay low.Thus,the friction is decreased and theaccuracy canbe maintained fora long period thantradition slidesystem.

1-1-2 High Rigidity

The designofLinearGuide features anequal load rating inall directions that provide sufficientngidity load in all directions,self-aligning capability to absorbinstallation-error.Moreove,asuffidentpreload canbe achievedto increase rigidity and makesit suitable for any kindof installation.

1-1-3 Easy for Maintenance

Compared with high-skill required scrapping process of traditional slide system,the Linear Guidecan offer high precision even if the mountingsurface is machined by milling or grinding.Moreover,the interchangeability of Linear Guide gives a conveniencefor installation and future maintenance.

1-1-4 HighSpeed

LinearGuide block,rail and ball apply by contact pointof rolling system.Due to the characteristicoflowfriction,the required driving force is much lower than that in other systems,thus the powerconsumption is low.Moreover the temperature rising effect is lower even under high speedoperation.

1-1-5 Super mute

The linear slider moves rapidly,the friction coefficient is verysmall and the noise is very low.It is widelyusedinsemi conductor and medical industries.

1-2 Recognizing of Master Rail

Linear rails to be applied on the same plane are all marked with the same serial number,and "M" is marked at the end of serial numberfor indicating the master rail,shown as the figure below.Therference side of carriage is the surface where is ground to a specified accuracy.For normal grade

(N),it has no mark "M"on rail which means any one of rails with same serial numbercould be themaster rail.

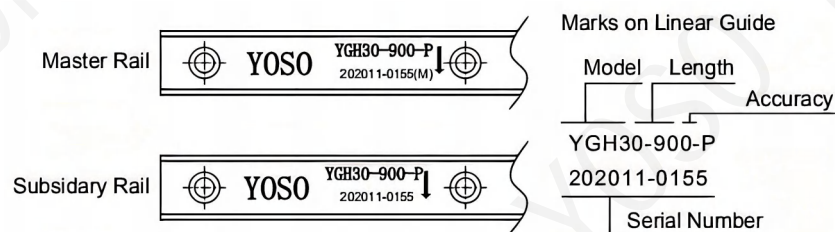

Fig 1.02 Recognizing of MasterRail

Combined Use of Rail and Carriage

For combined use,the rail and carriage must have the same serial number.When reinstalling thecarriage back to the rail,make sure they have the same serial number and the reference side ofcarriage should be in accordance with that of rail.

■ Installation of Linear Guide

1-3 For Butt-joint Rail

Accuracy may deviate at joints when carriages pass the joint simultaneously. Therefore, the joints should be interlaced for avoiding such accuracy problem.

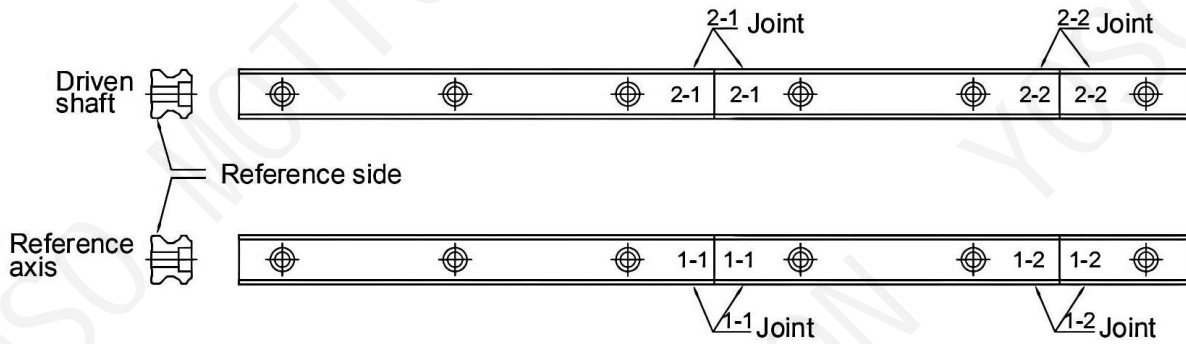

Fig 1.03 Butt-joint

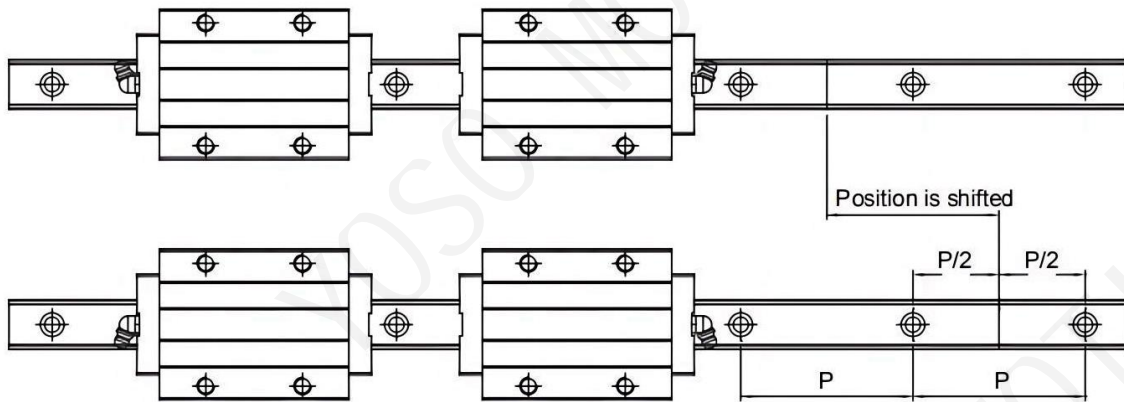

Fig 1.04

YG Series Heavy Load Ball Type

■ YG Series- Heavy Load Ball Type Linear Guideway

YG series linear guideways are designed with load capacity and rigidity higher than other similar products with circular-arc groove and structure optimization. It features equal load ratings in the radial, reverse radial and lateral directions, and self-aligning to absorb installation-error. Thus, YOSO YG series linear guideways can achieve a longlife with high speed, high accuracy and smooth linear motion.

2-1-1 Features of YG Series

(1) Self-aligning capability

By design, the circular-arc groove has contact points at 45 degrees. YG series can absorb most installation errors due to surface irregularities and provide smooth linear motion through the elastic deformation of rolling elements and the shift of contact points. Self-aligning capability, high accuracy and smooth operation can be obtained with an easy installation.

(2) Interchangeability

Because of precision dimensional control, the dimensional tolerance of YG series can be kept in a reasonable range. which means that any blocks and any rails in a specific series can be used together while maintaining dimensional tolerance. And a retainer is added to prevent the balls from falling out when the blocks are removed from the rail.

(3) High rigidity in all four directions

Because of precision dimensional control, the dimensional tolerance of YG series can be kept in a reasonable range. which means that any blocks and any rails in a specific series can be used together while maintaining dimensional tolerance. And a retainer is added to prevent the balls from falling out when the blocks are removed from the rail.

2-1-2 Construction of YG Series

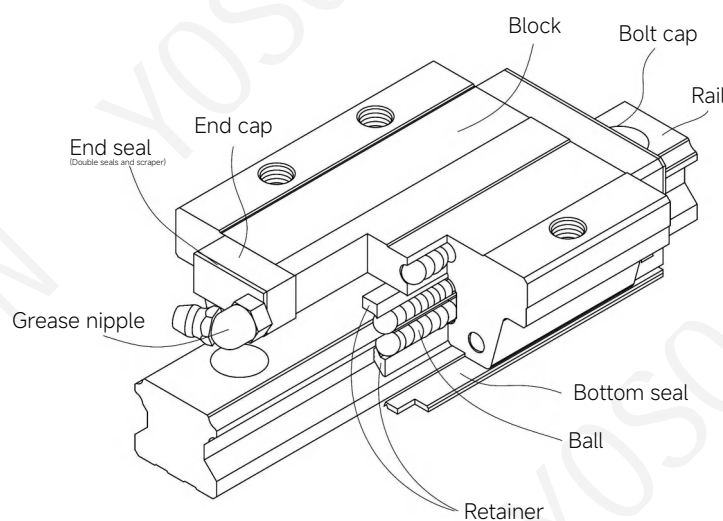

- Rolling circulation system: Block, Rail, End Cap and Retainer
- Lubrication system: Grease Nipple and Piping Joint
- Dust protection system: End seal, Bottom Seal, Bolt Cap, Double Seals and Scraper

2-1-3 Model Number of YG Series

YG series guideways can be classified into non-interchangeable and interchangeable types. The sizes are identical. The only difference between the two types is that the interchangeable type of blocks and rails can be freely exchanged, and their accuracy can reach up to P class. The model number of YG series contains the size, type, accuracy class, preload class, etc.

Y G H 20 L C/R - 2 - - 1200 - N - Z0 - II - U + N3 N3				
①	②	③	④	
Nominal Model	Block Type	Height of Assembly Type	Dimension	
Y	G:Standard S:Low-Assembly	R:Low-Assembly L:Middle-Assembly H:High-Assembly	15,20,25,30,35,45,55,65	
⑤	⑥	⑦	⑧	
Length of Block	Flange Type	Number of Block Per Rail	Accessory Code	
N:Normal L:Long	C:WithFlange R:Quartet	EX:2	<input type="checkbox"/> :Standard (Please refer to page A26)	
⑨	⑩	⑪	⑫	⑬
Length of Rai	Accuracy Grade	Preload	Two Sets per Axis	Rail Special Machining
Unit:mm	N:Norma H:High P:Precision SP:Super-Precision UP:Ultra-Precision	ZF:Slight Clearance Z0:No Preload Z1:Light Preload Z2:Medium Preload Z3:Heavy Preload	II	U:Tapped-Hole Rail E:Rail with Special Machining
⑭	⑮			
Block Surface Treatment	Rail Surface Treatment			
S:Standard B1:Black Oxidation N1:Hard Chrome Plating P:Phosphating N3:Nickel Plating N4:Raydent N5:Chrome Plating	S:Standard B1:Black Oxidation N1:Hard Chrome Plating P:Phosphating N3:Nickel Plating N4:Raydent N5:Chrome Plating			

No symbol required when plating is not needed

YOSO MOTION LINEAR GUIDE RAIL

YG Series Heavy Load Ball Type

■ Nominal Model Code for Interchangeable YG Type

Interchangeable Type of Block:

Y G H 20 L C- -N - Z0 + B1

① ② ③ ④ ⑤ ⑥ ⑦ ⑧ ⑨ ⑩

① Nominal Model	② Block Type	③ Height of Assembly Type	④ Dimension
Y	G:Standard S:Low-Assembly	R:Low-Assembly L:Middle-Assembly H:High-Assembly	15,20,25,30,35,45,55,65

⑤ Length of Block	⑥ Flange Type	⑦ Accessory Code	⑧ Accuracy Grade	⑨ Preload
N:Normal L:Long	C:With Flange R:Without Flange	<input type="checkbox"/> :Standard	N:Norma	ZF:Slight Clearance

⑩

Block Surface Treatment
S:Standard
B1:Black Oxidation
N1:Hard Chrome Plating
P:Phosphating
N3:Nickel Plating
N4:Raydent
N5:Chrome Plating

YG H 20 - 4000-N -U+B1

① ② ③ ④ ⑤ ⑥ ⑦

① Nominal Model	② Block Type	⑦ Block Surface Treatment
YG	H:Standard E:Special	S:Standard B1:Black Oxidation N1:Hard Chrome Plating P:Phosphating N3:Nickel Plating N4:Raydent N5:Chrome Plating
③ Dimension	④ Length of Rail	
15,20,25,30,35,45,55,65	Unit:mm L:Long	
⑤ Accuracy Grade	⑥ Rail Special Machining	
N:Norma	U:Tapped-Hole Rail E:Rail with Special Machining	

YG Series Heavy Load Ball Type

■ YG Series- Heavy Load Ball Type Linear Guideway

2-1-4 Type

(1) Blocktypes

There're two types of blocks: flange and square. The flange type is suitable for heavy moment load application because of the lower assembly height and wider mounting surface

Table 2-1-1 Block Types

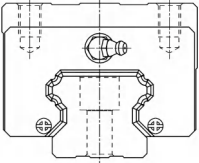
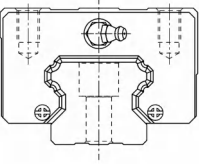
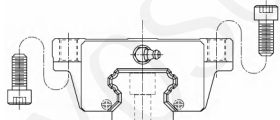
Type	Model	Shape	Height	Rail Length	Main Application
Standard	YGH-R	 Mounting from Above	28	100	<ul style="list-style-type: none"> ● Machine Centers. ● NC Lathes. ● Grinding Machines ● Precision Machining Machines ● Heavy Cutting Machines ● Automation Devices ● Transportation Equipment ● Measuring Equipment ● Devices Requiring High Positional Accuracy
	YGH-LR		90	6000	
	YGL-R	 Mounting from Above	24	100	
	TGL-SR		70	6000	
Flange	YGH-C	 Mounting from above and below	24	100	
	YGH-LC		90	6000	

(2) Rail types

Besides the standard top mounting type, the bottom mounting type is also available.

Table 2-1-2 Rail Types

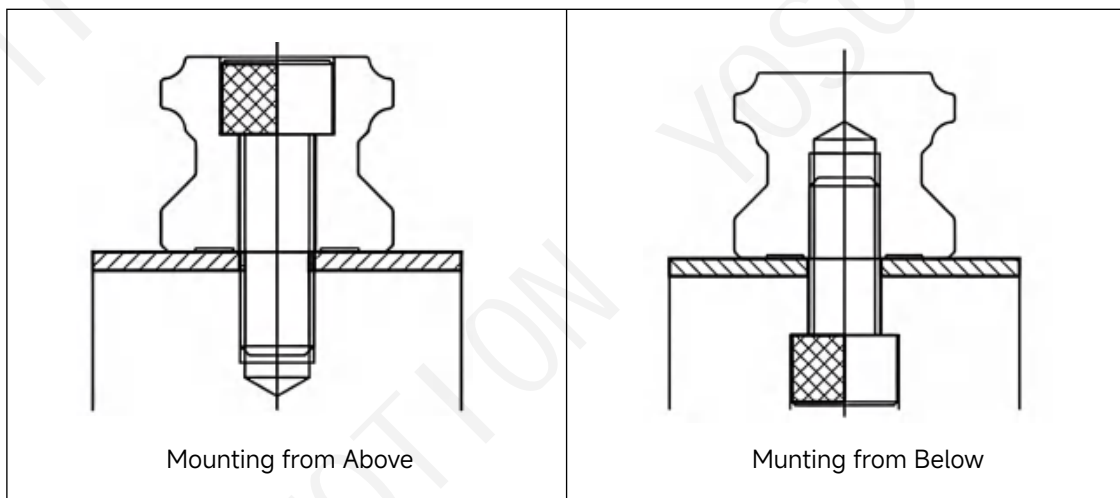

YOSO MOTION LINEAR GUIDE RAIL

YG Series Heavy Load Ball Type

■ YG Series- Heavy Load Ball Type Linear Guideway

2-1-5 Accuracy Classes

The accuracy of YG series can be classified into normal (C), high (H), precision (P), super precision (SP), ultra precision (UP), five classes. Please choose the class by referring the accuracy of applied equipment.

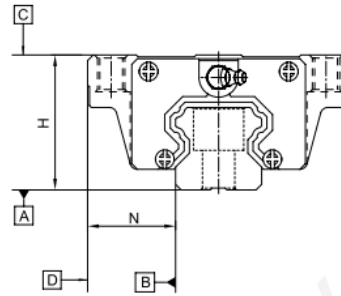

(1) Accuracy of non-interchangeable guideways

Table 2-1-3 Accuracy Standards

Item	YG-15,20				
	Normal [C]	High (H)	Precision [P]	Super Precision [SP]	Ultra Precision [UP]
Dimensional tolerance of height H	±0.1	±0.03	0 -0.03	0 -0.015	0 -0.008
Dimensional tolerance of width N	±0.1	±0.03	0 -0.03	0 -0.015	0 -0.008
Variation of height H	0.02	0.01	0.006	0.004	0.003
Variation of width N	0.02	0.01	0.006	0.004	0.003
Running parallelism of block surface C to surface A	See Table 2-1-11				
Running parallelism of block surface D to surface B	See Table 2-1-11				

Table 2-1-4 Accuracy Standards

Item	YG-25,30,35				
	Normal [C]	High (H)	Precision [P]	Super Precision [SP]	Ultra Precision [UP]
Dimensional tolerance of height H	±0.1	±0.04	0 -0.04	0 -0.02	0 -0.01
Dimensional tolerance of width N	±0.1	±0.04	0 -0.04	0 -0.02	0 -0.01
Variation of height H	0.02	0.015	0.007	0.005	0.003
Variation of width N	0.03	0.015	0.007	0.005	0.003
Running parallelism of block surface C to surface A	See Table 2-1-11				
Running parallelism of block surface D to surface B	See Table 2-1-11				

YG Series Heavy Load Ball Type

Table 2-1-5 Accuracy Standards

Item	YG-45,55				
	Normal [C]	High (H)	Precision [P]	Super Precision [SP]	Ultra Precision [UP]
Dimensional tolerance of height H	±0.1	±0.05	0 -0.05	0 -0.03	0 -0.02
Dimensional tolerance of width N	±0.1	±0.05	0 -0.05	0 -0.03	0 -0.02
Variation of height H	0.03	0.015	0.007	0.005	0.003
Variation of width N	0.03	0.02	0.01	0.007	0.005
Running parallelism of block surface C to surface A	See Table 2-1-11				
Running parallelism of block surface D to surface B	See Table 2-1-11				

Table 2-1-6 Accuracy Standards

Item	YG-65				
	Normal [C]	High (H)	Precision [P]	Super Precision [SP]	Ultra Precision [UP]
Dimensional tolerance of height H	±0.1	±0.07	0 -0.07	0 -0.05	0 -0.03
Dimensional tolerance of width N	±0.1	±0.07	0 -0.07	0 -0.05	0 -0.03
Variation of height H	0.03	0.02	0.01	0.007	0.005
Variation of width N	0.03	0.025	0.015	0.01	0.007
Running parallelism of block surface C to surface A	See Table 2-1-11				
Running parallelism of block surface D to surface B	See Table 2-1-11				

(2) Accuracy of interchangeable guideways

Table 2-1-7 Accuracy Standards

Item	YG-15,20		
	Normal [C]	High (H)	Precision [P]
Dimensional tolerance of height H	±0.1	±0.03	±0.015
Dimensional tolerance of width N	±0.1	±0.03	±0.015
Variation of height H	0.02	0.01	0.006
Variation of width N	0.02	0.01	0.006
Running parallelism of block surface C to surface A	See Table 2-1-11		
Running parallelism of block surface D to surface B	See Table 2-1-11		

YOSO MOTION LINEAR GUIDE RAIL

YG Series Heavy Load Ball Type

Table 2-1-8 Accuracy Standards

Item	YG-25,30,35		
	Normal [C]	High (H)	Precision [P]
Dimensional tolerance of height H	±0.1	±0.04	±0.02
Dimensional tolerance of width N	±0.1	±0.04	±0.02
Variation of height H	0.02	0.015	0.007
Variation of width N	0.03	0.015	0.007
Running parallelism of block surface C to surface A	See Table 2-1-11		
Running parallelism of block surface D to surface B	See Table 2-1-11		

Table 2-1-9 Accuracy Standards

Item	YG-45,55		
	Normal [C]	High (H)	Precision [P]
Dimensional tolerance of height H	±0.1	±0.05	±0.025
Dimensional tolerance of width N	±0.1	±0.05	±0.025
Variation of height H	0.02	0.015	0.007
Variation of width N	0.03	0.02	0.007
Running parallelism of block surface C to surface A	See Table 2-1-11		
Running parallelism of block surface D to surface B	See Table 2-1-11		

Table 2-1-10 Accuracy Standards

Item	YG-65		
	Normal [C]	High (H)	Precision [P]
Dimensional tolerance of height H	±0.1	±0.07	±0.035
Dimensional tolerance of width N	±0.1	±0.07	±0.035
Variation of height H	0.03	0.02	0.01
Variation of width N	0.03	0.025	0.015
Running parallelism of block surface C to surface A	See Table 2-1-11		
Running parallelism of block surface D to surface B	See Table 2-1-11		

YG Series Heavy Load Ball Type

(2) Accuracy of interchangeable guideways

Table 2-1-11 Accuracy Standards

Rail Length (mm)	Accuracy(μm)				
	C	H	P	SP	UP
~100	12	7	3	2	2
100~200	14	9	4	2	2
200~300	15	10	5	3	2
300~500	17	12	6	3	2
500~700	20	13	7	4	2
700~900	22	15	8	5	3
900~1100	24	16	9	6	3
1100~1500	26	18	11	7	4
1500~1900	28	20	13	8	4
1900~2500	31	22	15	10	5
2500~3100	33	25	18	11	6
3100~3600	36	27	20	14	7
3600~4000	37	28	21	15	7

YOSO MOTION LINEAR GUIDE RAIL

YG Series Heavy Load Ball Type

2-1-6 Preload

(1) Definition

Each guide rail can be preloaded and oversized balls are used. Generally, linear guides leave a negative gap between the groove and the ball to increase rigidity and maintain high precision. The figure shows that when the load is multiplied by the preload, the rigidity is doubled and the deflection is reduced by half. It is recommended that the preload of models below YG20 should not be greater than ZA to avoid excessive preload affecting the life of the guide rail.

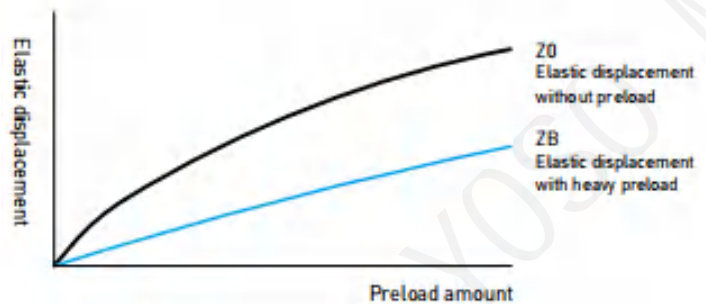

(2) Preload classes

YOSO offers three classes of standard preload for various applications and conditions.

Table 2-1-13 Preload classes

Class	Code	Preload	Condition	Condition
Light Preload	Z0	0-0.02C	Certain load direction, low impact, low precision required	Transportation devices, auto-packing machines, X-Y axis for general industrial machines, welding machines, welders
Medium Preload	ZA	0.05C-0.07C	High precision required	Machining centers, Z axis for general industrial machines, EDM, NC lathes, Precision X-Y tables, measuring equipment
Heavy Preload	ZB	0.10C-0.12C	High rigidity required, with vibration and impact	Machining centers, grinding machines, NC lathes, horizontal and vertical milling machines, Z axis of machine tools, Heavy cutting machines
Class	Interchangeable Guideway		Non-Interchangeable Guideway	
Preload classes	Z0, ZA		Z0, ZA, ZB	

Note: The "C" in the preload column denotes basic dynamic load rating.

(3) Stiffness performance

Stiffness depends on preload. The following table shows stiffness value of each size.

Table 2-1-13 Radial stiffness for YG Series

Load type	Series/Size	Stiffness (N/μm)		
		Z0	ZA	ZB
Heavy load	HG 15C	196	365	483
	HG 20C	232	460	678
	HG 25C	292	539	705
	HG 30C	354	618	823
	HG 35C	395	642	865
	HG 45C	505	738	980
	HG 55C	609	828	1092
	HG 65C	716	918	1201
Super heavy load	HG 20H	300	611	824
	HG 25H	378	715	935
	HG 30H	453	820	1093
	HG 35H	509	855	1150
	HG 45H	649	970	1298
	HG 55H	789	1085	1445
	HG 65H	946	1221	1599

YG Series Heavy Load Ball Type

2-1-7 Lubrication

(1) Grease

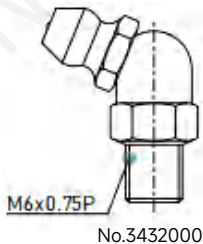
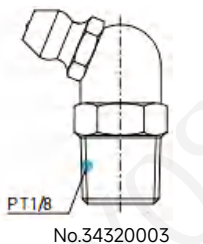
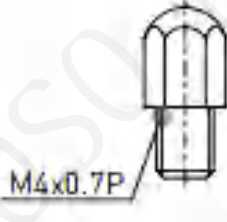
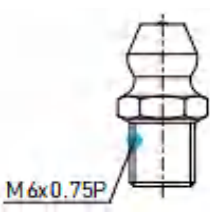
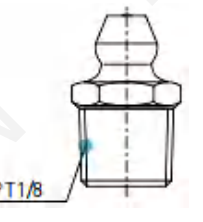
<p>● Grease nipple</p>	 <p>YG20 YG25 YG30 YG35</p> <p>M6x0.75P No.34320001</p>	 <p>YG45 YG55 YG65</p> <p>PT1/8 No.34320003</p>
 <p>YG15</p> <p>M4x0.7P No.34310002</p>	 <p>YG20 YG25 YG30 YG35</p> <p>M6x0.75P No.34310003(OPTION)</p>	 <p>YG45 YG55 YG65</p> <p>PT1/8 No.3431000B(OPTION)</p>

● Mounting location

The standard location for the grease fittings is at either end of the cylinder body, but the fittings can be mounted on either side of the cylinder body. For side mounting, please contact YOSO to pre-drill holes in the desired location.

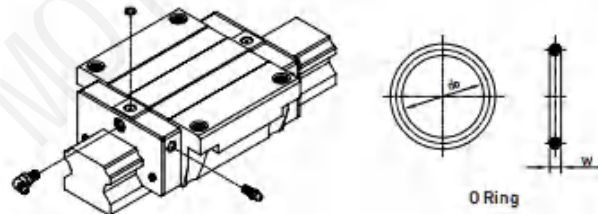
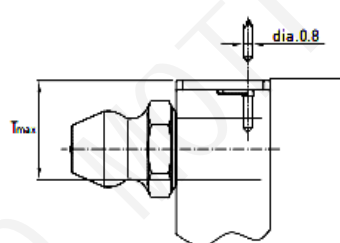

Table 2-1-14 O-Ring size and max. permissible depth for piercing

Size	O-Ring		Lube hole at top: max. permissible depth for piercing
	do (mm)	W(mm)	T _{max} (mm)
YG15	2.5±0.15	1.5±0.15	3.75
YG20	4.5±0.15	1.5±0.15	5.7
YG25	4.5±0.15	1.5±0.15	5.8
YG30	4.5±0.15	1.5±0.15	6.3
YG35	4.5±0.15	1.5±0.15	8.8
YG45	4.5±0.15	1.5±0.15	8.2
YG55	4.5±0.15	1.5±0.15	11.8
YG65	4.5±0.15	1.5±0.15	10.8



● The lubricant amount for a block filled with grease

Table 2-1-15 The lubricant Amount for a Block Filled with Grease

Size	Heavy load [cm ³]	Super heavy load [cm ³]	Size	Heavy load [cm ³]	Super heavy load [cm ³]
YG15	1	-	YG35	10	12
YG20	2	3	YG45	17	21
YG25	5	6	YG55	26	33
YG30	7	8	YG65	50	61

● Frequency of replenishment

Check the grease every 100 km, or every 3-6 months.

YOSO MOTION LINEAR GUIDE RAIL

YG Series Heavy Load Ball Type

(2) Oil

The recommended viscosity of oil is about 30~150cSt. If customers need to use oil-type lubrication, please inform us.

<p>LF-64</p> <p>No.97000EA1</p>	<p>LF-76</p> <p>YG20 YG25 YG30 YG35</p> <p>No.970002A1</p>	<p>LF-78</p> <p>YG45 YG55 YG65</p> <p>No.970006A1</p>
<p>SF-64</p> <p>YG15</p> <p>No.97001TA1</p>	<p>LF-86</p> <p>YG20 YG25 YG30 YG35</p> <p>No.970004A1</p>	<p>LF-88</p> <p>YG45 YG55 YG65</p> <p>No.970008A1</p>
<p>SF-76</p> <p>YG20 YG25 YG30 YG35</p> <p>No.970001A1</p>	<p>SF-78</p> <p>YG45 YG55 YG65</p> <p>No.970005A1</p>	
<p>SF-86</p> <p>YG20 YG25 YG30 YG35</p> <p>No.970003A1</p>	<p>SF-88</p> <p>YG45 YG55 YG65</p> <p>No.970007A1</p>	

YG Series Heavy Load Ball Type

● Oil refilling rate

Table 2-1-16

Size	Refilling rate (cm ³ /hr)	Size	Refilling rate (cm ³ /hr)
YG15	0.2	YG35	0.3
YG20	0.2	YG45	0.4
YG25	0.3	YG55	0.5
YG30	0.3	YG65	0.6

2-1-8 Dust Proof Accessories

(1) Codes of standard dust proof accessories

If the following accessories are needed, please add the code followed by the model number.

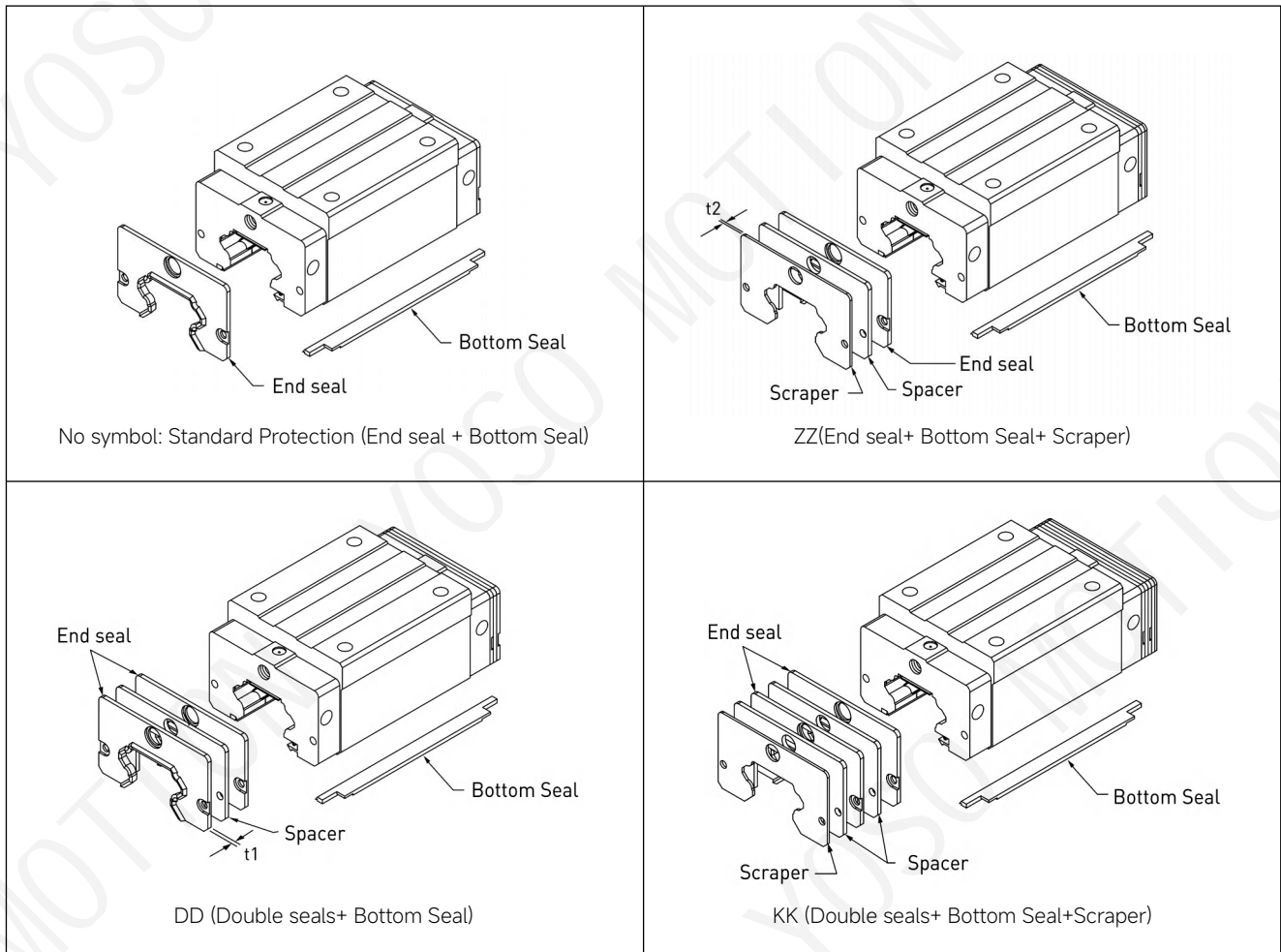

Note: YG20/25/65 are without spacer.

YOSO MOTION LINEAR GUIDE RAIL

YG Series Heavy Load Ball Type

(2) Codes of high-dust proof accessories

YOSO has developed a variety of dust protection accessories for different applications and working environments to avoid dust or debris. If you need the following accessories, please add the code after the model number.

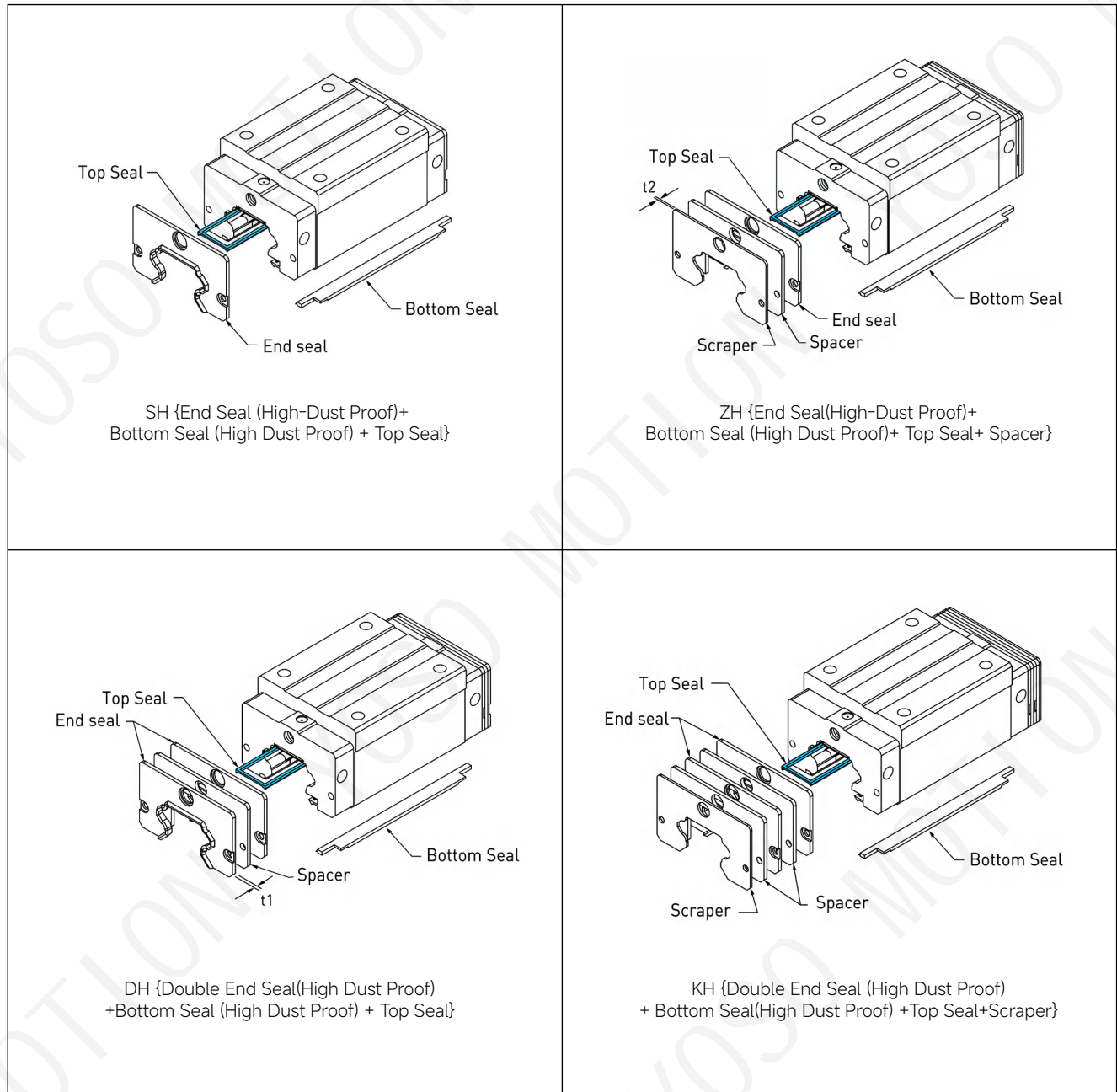

Note:

1. The available size for high dust proof accessories are HG20IC/H), 251C/H), 301C/H), 351C/H) and 45C
2. The value of friction force will increase 0.6-1.2 kgf.
- 3.YG20/25 are without spacer.
4. If higher dust proof accessories is needed , please contact YOSO.

YG Series Heavy Load Ball Type

(3) Codes of ultra-high dust proof accessories

YOSO has developed high dust-resistant accessories for use in environments filled with dust and particles, such as wood-working machinery and glass/stone processing equipment. These accessories have high dust resistance. If you need an accessory, please add the code after the model number.

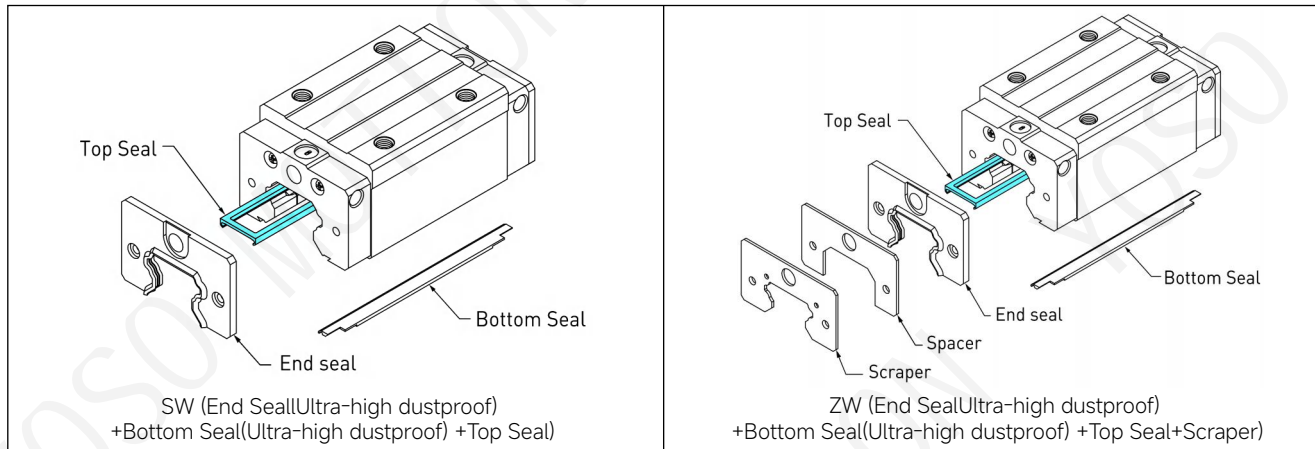

Note:

- 1.The available size for high dust proof accessories are YG15C,HG20(C/H),YG25(C/H),YG30(C/H),YG35(C/H),YG45(C/H)
- 2.The value of friction force will increase 1.5~4.0kgf.
- 3.MGN5 is only supplied with End Seal[Ultra-high dustproof]

(4) Function of dust proof accessories

- End seal and bottom seal

To prevent life reduction caused by iron chips or dust entering the block.

- Double seals

Enhances the wiping effect, foreign matter can be completely wiped off.

Table 2-1-17 Dimensions of end seal

Size	Thickness (t1) (mm)	Size	Thickness (t1) (mm)
YG15 ES	3	YG35 ES	3.2
YG20 ES	3.5	YG45 ES	4.5
YG25 ES	3.5	YG55 ES	4.5
YG30 ES	3.2	YG65 ES	6

- Scraper

The scraper removes high-temperature iron chips and larger foreign objects.

Table 2-1-18 Dimensions of scraper

Size	Thickness (t2) (mm)	Size	Thickness (t2) (mm)
YG15 SC	1.5	YG35 SC	1.5
YG20 SC	1.5	YG45 SC	1.5
YG25 SC	1.5	YG55 SC	1.5
YG30 SC	1.5	YG65 SC	1.5

- Top Seal

Top seal can efficiently avoid dust from the surface of rail or tapping hole getting inside the block.

YOSO MOTION LINEAR GUIDE RAIL

YG Series Heavy Load Ball Type

- Bolt caps for rail mounting holes

Caps are used to cover the mounting holes to prevent chips or other foreign objects from collecting in the holes. The caps will be enclosed in each rail package.

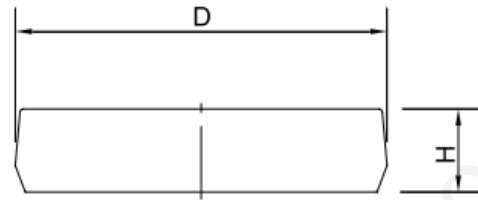

Table 2-1-19 Dimensions of Bolt Caps for Rail Mounting Holes

Rail size	Bolt size	Diameter(D) (mm)	Thickness(H) (mm)	Rail size	Bolt size	Diameter(D) (mm)	Thickness(H) (mm)
YGR15	M4	7.65	1.1	YGR35	M8	14.20	3.5
YGR20	M5	9.65	2.5	YGR45	M12	20.25	4.5
YGR25	M6	11.15	2.5	YGR55	M14	23.25	5.0
YGR30	M8	14.20	3.5	YGR65	M16	26.35	5.0

(5) Dimensions of block equipped with the parts

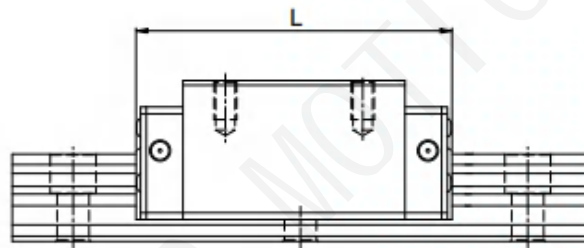

Table 2-1-20 Overall block length

Size	Overall block length(L)					
	SS/SH	ZZ/ZH	DD/DH	KK/KH	SW	ZW
YG15C	61.4[61.8]	69.0(69.0)	68.0(68.4)	75.6(75.6)	63.2(63.2)	71.0(71.0)
*YG20C	77.5(79.3)	82.5(84.5)	82.5(84.3)	87.5(89.5)	78.5(78.5)	86.3(87.7)
*YG20H	92.2 (94.0)	97.2(99.2)	97.5(99.0)	102.2(104.2)	93.2(93.2)	101.0(102.4)
*YG25C	84.0(85.0)	89.0(91.0)	89.0(90.0)	94.0(96.0)	85.0(85.0)	92.8(94.8)
*YG25H	104.6(105.6)	109.6(111.6)	109.6(110.6)	114.6(116.6)	105.6(105.6)	113.4(115.4)
*YG30C	97.4(99.4)	105.4(107.4)	104.8(106.8)	112.8(114.8)	99.0(100.4)	107.2(109.2)
*YG30H	120.4(122.4)	128.4(130.4)	127.8(129.8)	135.8(137.8)	122.0(123.4)	130.2(132.2)
*YG35C	112.4(114.4)	120.4(122.4)	119.8(121.8)	127.8(129.8)	115.2(116.0)	123.4(125.4)
*YG35H	138.2(140.2)	146.2(148.2)	145.6(147.6)	153.6(155.6)	141.0(141.8)	149.2(151.2)
*YG45C	139.4(139.4)	150.0(150.0)	149.4(149.4)	160.0(160.0)	140.0(140.0)	148.8(150.2)
YG45H	171.2(171.2)	181.8(181.8)	181.2(181.2)	191.8(191.8)	171.8(171.8)	180.6(182.0)
YG55C	166.7(166.7)	177.1(177.1)	177.1(177.1)	187.5(187.5)	-	-
YG55H	204.8(204.8)	215.2(215.2)	215.2(215.2)	225.6(225.6)	-	-
YG65C	200.2(200.2)	208.2(208.2)	209.2(209.2)	217.2(217.2)	-	-
YG65H	259.6(259.6)	267.6(267.6)	268.6(268.6)	276.6(276.6)	-	-

Note:

1.For the marking of "**", it means this specification is available for SH/ZH/DH/KH dust proof accessories.

2.The marking of "T" denotes the maximum block length with screws, lips of end seals, etc

YG Series Heavy Load Ball Type

2-1-9 Friction

The maximum value of resistance per end seal are as shown in the table.

Table 2-1-21 Seal Resistance

Bolt size	Resistance N (kgf)	Bolt size	Resistance N (kgf)
YG15	2.35(0.24)	YG35	4.91(0.5)
YG20	2.75(0.28)	YG45	3.83(0.39)
YG25	3.14(0.32)	YG55	4.61(0.47)
YG30	3.53(0.36)	YG65	5.79(0.59)

Note:

- 1kgf=9.81N
- Please inform HIWIN if low friction request is required.

2-1-10 The Accuracy Tolerance of Mounting Surface

(1) The accuracy tolerance of rail-mounting surface

Because of the circular-arc contact design, the HG linear guideway can compensate for some surface-error on installation and still maintain smooth linear motion. As long as the accuracy requirements for the mounting surface are followed, high accuracy and rigidity of linear motion of the guideway can be obtained without any difficulty. For fast installation and smooth movement ability of the deviation in mounting surface accuracy.

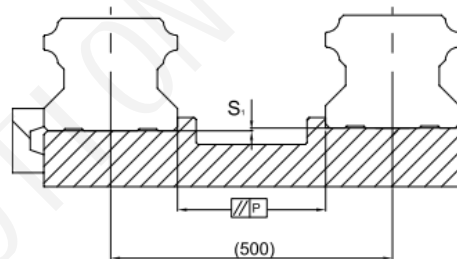

(2) The parallelism tolerance of reference surface (P)

Table 2-1-22 Max. Parallelism Tolerance (P)

Size	Preload classes		
	Z0	ZA	ZB
YG15	25	18	13
YG20	25	20	18
YG25	30	22	20
YG30	40	30	27
YG35	50	35	30
YG45	60	40	35
YG55	70	50	45
YG65	80	60	55

(3) The accuracy tolerance of reference surface height

Table 2-1-23 Max. Tolerance of Reference Surface Height (s)

Size	Preload classes		
	Z0	ZA	ZB
YG15	130	85	35
YG20	130	85	50
YG25	130	85	70
YG30	170	110	90
YG35	210	150	120
YG45	250	170	140
YG55	300	210	170
YG65	350	250	200

Note: Permissible value is proportional to the axial distance

YOSO MOTION LINEAR GUIDE RAIL

YG Series Heavy Load Ball Type

2-1-11 Cautions for Installation

(1) Shoulder heights and fillets

Improper shoulder height and radii on the mounting surface can cause accuracy deviations and interference with the rail or slide. Installation inaccuracies can be eliminated by following the recommended shoulder height and radii.

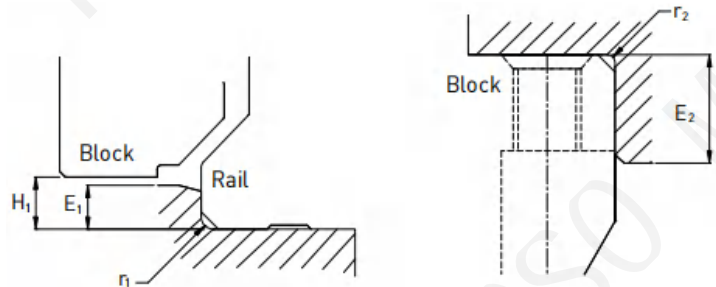

Table 2-1-24 Shoulder Heights and Fillets

Size	Max.radius of fillets	Max.radius of fillets	Shoulder height beside the rail	Shoulder height beside the rail	Clearance under block
	r ₁ (mm)	r ₂ (mm)	E ₁ (mm)	E ₂ (mm)	H ₁ (mm)
YG15	0.5	0.5	3	4	4.3
YG20	0.5	0.5	3.5	5	4.6
YG25	1.0	1	5	5	5.5
YG30	1.0	1	5	5	6
YG35	1.0	1	6	6	7.5
YG45	1.0	1	8	8	9.5
YG55	1.5	1.5	10	10	13
YG65	1.5	1.5	10	10	15

(2) Tightening Torque of Bolts for Installation

Improper tightening of bolts will seriously influence the accuracy of Linear Guideway installation. The following tightening torques for different sizes of bolts are recommended.

Table 2-1-25 Mounting Torque

Size	Bolt size	Torque N-cm (kgf-cm)		
		Iron	Casting	Aluminum
YG15	M4×0.7P×16L	392(40)	274(28)	206(21)
YG20	M5×0.8P×16L	883(90)	588(60)	441(45)
YG25	M6×1P×20L	1373(140)	921(94)	686(70)
YG30	M8×1.25P×25L	3041(310)	2010(205)	1470(150)
YG35	M8×1.25P×25L	3041(310)	2010(205)	1470(150)
YG45	M12×1.75P×35L	11772(1200)	7840(800)	5880(600)
YG55	M14×2P×45L	15696(1600)	10500(1100)	7840(800)
YG65	M16×2P×50L	19620(2000)	13100(1350)	9800(1000)

Note: 1 kgf=9.81 N

YG Series Heavy Load Ball Type

2-1-12 Standard and Maximum Lengths of Rail

YOSO offers standard rail lengths for customer needs, For non-standard E-values, the recommended dimensions should not be greater than 1/2 of the pitch [P] dimension. This will prevent an unstable rail end.

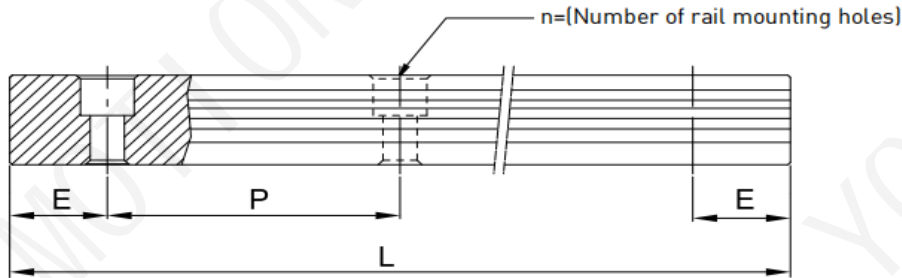

$$L = (n-1) \times P + 2 \times E \quad \dots \dots \dots \text{Eq.2.1}$$

L: Total length of rail (mm)
 n: Number of mounting holes
 P: Distance between any two holes [mm]
 E: Distance from the center of the last hole to the edge (mm)

Table 2-1-26 Rail Standard Length and Max. Length

Item	YG15	YG20	YG25	YG30	YG35	YG45	YG55	YG65
Standard Length L(n)	160(3)	220(4)	220(4)	280(4)	280(4)	570(6)	780(7)	1,270(9)
	220(4)	280(5)	280(5)	440(6)	440(6)	885(9)	1,020(9)	1,570(11)
	280(5)	340(6)	340(6)	600(8)	600(8)	1,200(12)	1,260(11)	2,020(14)
	340(6)	460(8)	460(8)	760(10)	760(10)	1,620(16)	1,500(13)	2,620(18)
	460(8)	640(11)	640(11)	1,000(13)	1,000(13)	2,040(20)	1,980(17)	
	640(11)	820(14)	820(14)	1,640(21)	1,640(21)	2,460(24)	2,580(22)	
	820(14)	1,000(17)	1,000(17)	2,040(26)	2,040(26)	2,985(29)	2,940(25)	
		1,240(21)	1,240(21)	2,520(32)	2,520(32)			
			1,600(27)	3,000(38)	3,000(38)			
Pitch(P)	60	60	60	80	80	105	120	150
Distance to End (E.)	20	20	20	20	20	22.5	30	35
Max. Standard Length	4,000(67)	4,000(67)	4,000(67)	3,960(50)	3,960(50)	3,930(38)	3,900(33)	3,970(27)
Max. Length	4,000	4,000	4,000	4,000	4,000	4,000	4,000	4,000

- Note :
1. Tolerance of E value for standard rail is 0.5--0.5 mm. Tolerance of E value for jointed rail is 0--0.3 mm.
 2. Maximum standard length means the max. rail length with standard E value on both sides.
 3. If different E value is needed, please contact YOSO.
 4. YGR15/YGR20/YGR25 of stainless steel is supplied with the maximum length of 2000mm.

YOSO MOTION LINEAR GUIDE RAIL

YG Series Heavy Load Ball Type

2-1-13 Dimensions for YOSO YG

(1) YGH-R/YGH-LR

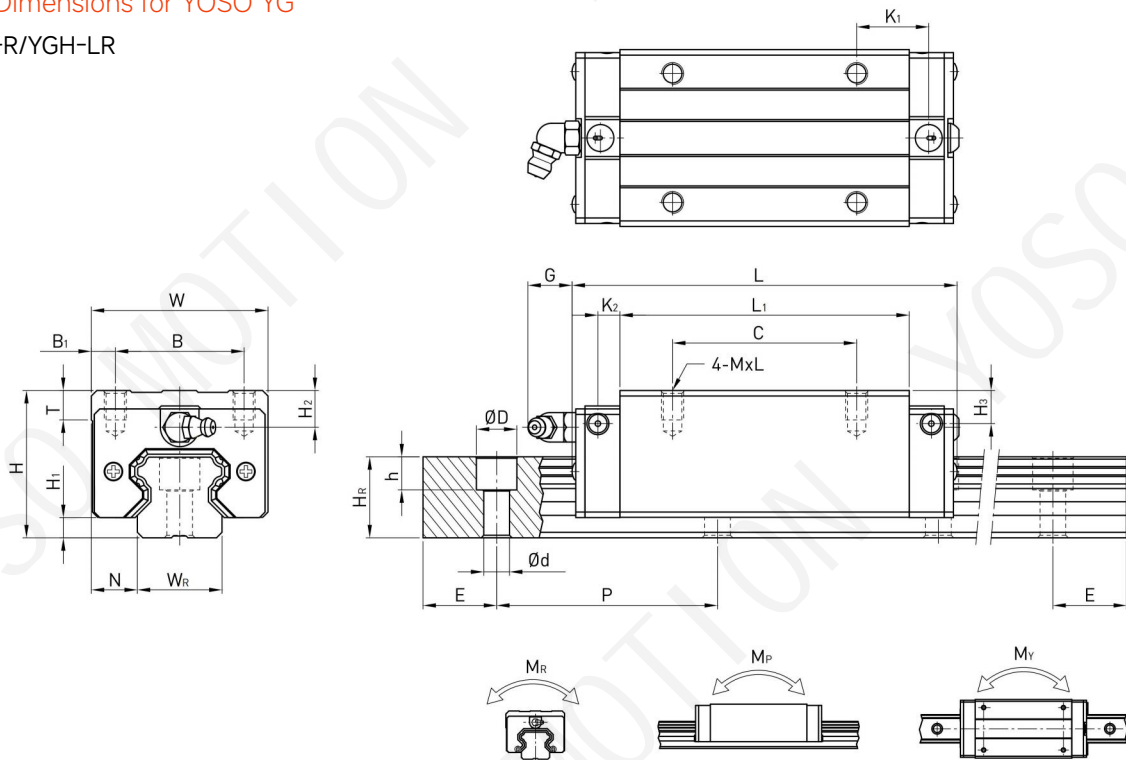

Model No.	Dimensions of Assembly (mm)			Dimensions of Block (mm)											Dimensions of Rail (mm)						Mounting Bolt for Rail (mm)	Basic Dynamic Load Rating C(kN)	Basic Static Load Rating Co(kN)	Static Rated Moment			Weight				
	H	H1	N	W	B	B1	C	Li	L	K1	K2	G	MxL	T	H2	H3	W	Hr	D	h				d	P	E	MR kN-m	Mp kN-m	My kN-m	Block kg	Rail kg/m
YGH15R	28	4.3	9.5	34	26	4	26	39.4	61.4	10	4.85	5.3	M4x5	6	795	7.7	15	15	7.5	5.3	4.5	60	20	M4x16	14.7	23.47	0.12	0.10	0.10	0.18	1.45
YGH20R	30	4.6	12	44	32	6	36	50.5	77.5	12.25	6	12	M5x6	8	6	6	20	17.5	9.5	8.5	6	60	20	M5x16	27.1	36.68	0.27	0.20	0.20	0.30	2.21
YGH20LR							50	65.2	92.2	12.6															32.7	47.96	0.35	0.35	0.35	0.39	
YGH25R	40	5.5	12.5	48	35	6.5	35	58	84	15.7	6	12	M6x8	8	10	9	23	22	11	9	7	60	20	M6x20	34.9	52.82	0.42	0.33	0.33	0.51	3.21
YGH25LR							50	78.6	104.6	18.5															42.2	69.07	0.56	0.57	0.57	0.69	
YGH30R	45	6	16	60	40	10	40	70	97.4	20.25	6	12	M8x10	8.5	9.5	13.8	28	26	14	12	7	80	20	M8x25	48.5	71.87	0.66	0.53	0.53	0.88	4.47
YGH30LR							60	93	120.4	21.75															58.6	93.99	0.88	0.92	0.92	1.16	
YGH35R	55	7.5	18	70	50	10	50	80	112.4	20.6	7	12	M8x12	10.2	16	19.6	34	29	14	12	9	80	20	M8x25	64.6	93.88	1.16	0.81	0.81	1.45	6.30
YGH35LR							72	105.8	138.2	22.5															77.9	122.77	1.54	1.40	1.40	1.92	
YGH45R	70	9.5	20.5	86	60	13	60	97	139.4	23	10	12.9	M10x17	16	18.5	30.5	45	38	20	17	14	105	22.5	M12x35	103.8	146.71	1.98	1.55	1.55	2.73	10.41
YGH45LR							80	128.8	171.2	28.9															125.3	191.85	2.63	2.68	2.68	3.61	
YGH55R	80	13	23.5	100	75	12.5	75	117.7	166.7	27.35	11	12.9	M12x18	17.5	22	29	53	44	23	20	16	120	30	M14x45	153.2	211.23	3.69	2.64	2.64	4.17	15.08
YGH55LR							95	155.8	204.8	36.4															184.9	276.23	4.88	4.57	4.57	5.49	
YGH65R	90	15	31.5	126	25	25	70	144.2	200.2	43.1	14	12.9	M16x20	25	15	15	63	53	26	22	18	150	35	M16x50	213.2	287.48	6.65	4.27	4.27	7.00	21.18
YGH65LR							120	203.6	259.6	47.8															277.8	420.17	9.38	7.38	7.38	9.82	

Note : 1 kgf= 9.81 N

YG Series Heavy Load Ball Type

(2) YGL-R/YGL-LR

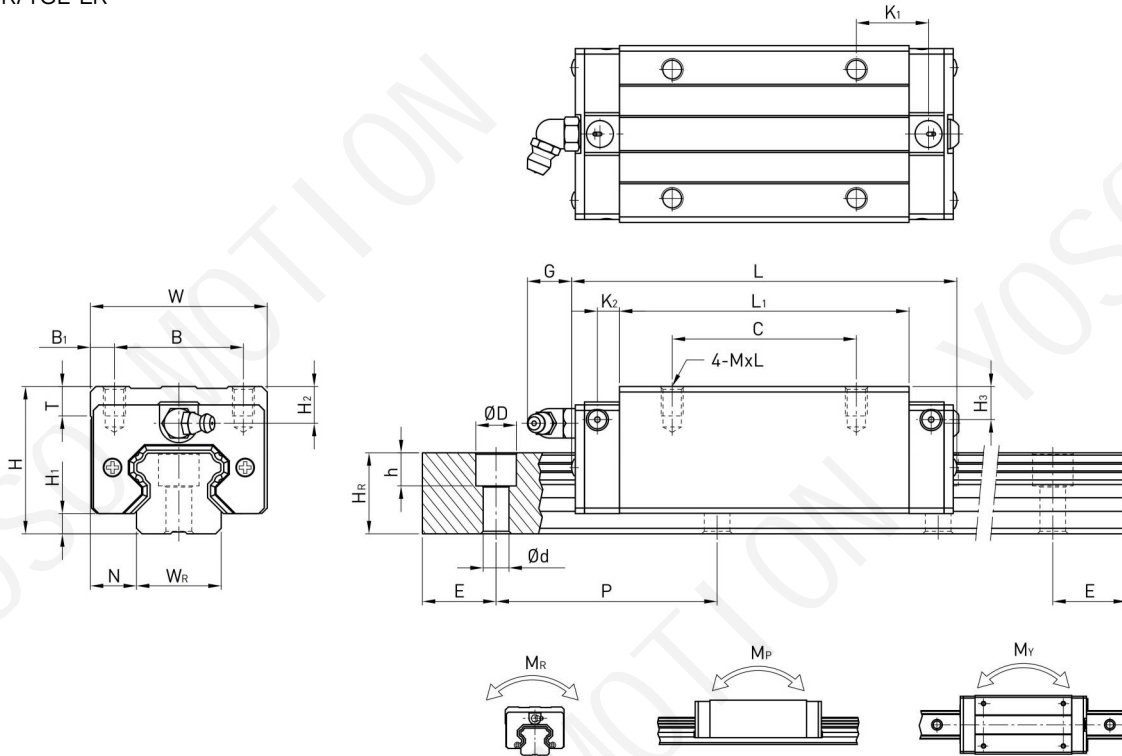

Model No.	Dimensions of Assembly (mm)			Dimensions of Block (mm)												Dimensions of Rail (mm)					Mounting Bolt for Rail (mm)	Basic Dynamic Load Rating C (kN)	Basic Static Load Rating Co (kN)	Static Rated Moment			Weight				
	H	H ₁	N	W	B	B ₁	C	L ₁	L	K ₁	K ₂	G	MxL	T	H ₂	H ₃	W	H _R	D	h				d	P	E	MR (kN-m)	Mp (kN-m)	My (kN-m)	Block (kg)	Rail (kg/m)
YGL15R	28	4.3	9.5	34	26	4	26	39.4	61.4	10	4.85	5.3	M4x4	6	3.95	3.7	15	15	7.5	5.3	4.5	60	20	M4x16	14.7	23.47	0.12	0.10	0.10	0.14	1.45
YGL25R	36	5.5	12.5	48	6	6.5	35	58	84	15.7	6	12	M6x6	8	6	5	23	22	11	9	7	60	20	M6x20	34.9	52.82	0.42	0.33	0.33	0.42	3.21
YGL25LR							50	78.6	104.6	18.5															42.2	69.07	0.56	0.57	0.57	0.57	
YGL30R	42	6	16	60	40	10	40	70	97.4	20.25	6	12	M8x10	8.5	6.5	10.8	28	26	14	12	9	80	20	M8x25	48.5	71.87	0.66	0.53	0.53	0.78	4.47
YGL30LR							60	93	120.4	21.75															58.6	93.99	0.88	0.92	0.92	1.03	
YGL35R	48	7.5	18	70	50	10	60	80	112.4	20.6	7	12	M8x12	10.2	9	12.6	34	29	14	12	9	80	20	M8x25	64.6	93.88	1.16	0.81	0.81	1.14	6.30
YGL35LR							72	105.8	138.2	22.5															77.9	122.77	1.54	1.40	1.40	1.52	
YGL45R	60	9.5	20.5	86	60	13	60	97	139.4	23	10	12.9	M10x17	16	8.5	20.5	45	38	20	17	14	105	22.5	M12x35	103.8	146.71	1.98	1.55	1.55	2.08	10.41
YGL45LR							80	128.8	171.2	28.9															125.3	191.85	2.63	2.68	2.68	2.75	
YGL55R	70	3	23.5	100	75	12.5	75	117.7	166.7	27.35	11	12.9	M12x18	17.5	12	19	53	44	23	20	16	120	20	M14x45	153.2	211.23	3.69	2.64	2.64	3.25	15.08
YGL55LR							95	155.8	204.8	36.4															184.9	276.23	4.88	4.57	4.57	4.27	

Note : 1 kgf= 9.81 N

YOSO MOTION LINEAR GUIDE RAIL

YG Series Heavy Load Ball Type

(3) YGH-C/YGH-LC

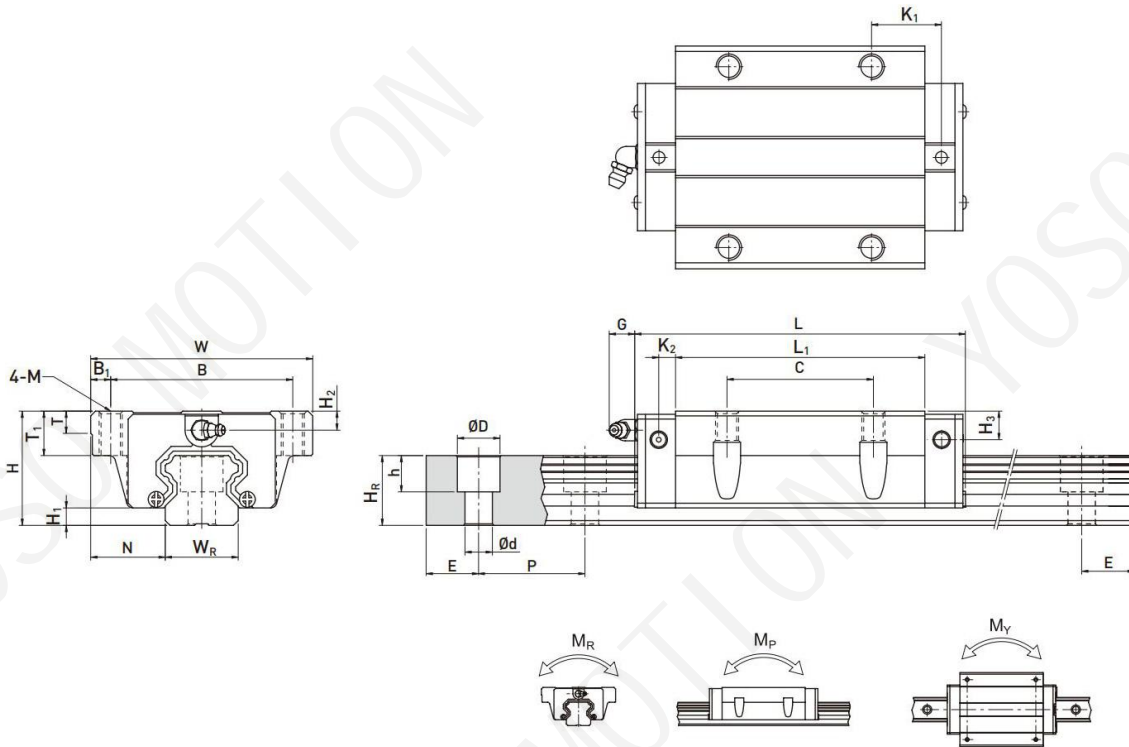

Model No.	Dimensions of Assembly (mm)			Dimensions of Block (mm)														Dimensions of Rail (mm)							Mounting Bolt for Rail (mm)	Basic Dynamic Load Rating C(kN)	Basic Static Load Rating Co(kN)	Static Rated Moment			Weight	
	H	H ₁	N	W	B	B ₁	C	L ₁	L	K ₁	K ₂	G	M	T	T ₁	H ₂	H ₃	W _R	H _R	D	h	d	P	E				M _R (kN-m)	M _P (kN-m)	M _Y (kN-m)	Block (kg)	Rail (kg/m)
YGH15C	24	4.3	16	47	38	4.5	30	39.4	61.4	8	4.85	5.3	M5	6	8.9	3.95	3.7	15	15	7.5	5.3	4.5	60	20	M4x16	14.7	23.47	0.12	0.10	0.10	0.17	1.45
YGH20C	30	4.6	21.5	63	53	5	40	50.5	77.5	10.25	6	12	M6	8	10	6	6	20	17.5	9.5	8.5	6	60	20	M5x16	27.1	36.68	0.27	0.20	0.20	0.40	2.21
YGH20LC								65.2	92.2	17.6																32.7	47.96	0.35	0.35	0.35	0.52	
YGH25C	36	5.5	23.5	70	57	6.5	45	58	84	10.7	6	12	M8	8	14	6	5	23	22	11	9	7	60	20	M6x20	34.9	52.82	0.42	0.33	0.33	0.59	3.21
YGH25LC								78.6	104.6	21																42.2	69.07	0.56	0.57	0.57	0.80	
YGH30C	42	6	31	90	72	9	52	70	97.4	14.25	6	12	M10	8.5	16	6.5	10.8	28	26	14	12	9	80	20	M8x25	48.5	71.87	0.66	0.53	0.53	1.09	4.47
YGH30LC								93	120.4	25.75																58.6	93.99	0.88	0.92	0.92	1.44	
YGH35C	48	7.5	33	100	82	9	62	80	112.4	14.6	7	12	M10	10.1	18	9	12.6	34	29	14	12	9	80	20	M8x25	64.6	93.88	1.16	0.81	0.81	1.56	6.30
YGH35LC								105.8	138.2	27.5																77.9	122.77	1.54	1.40	1.40	2.06	
YGH45C	60	9.5	37.5	120	100	10	80	97	139.4	13	10	12.9	M12	15.1	22	8.5	20.5	45	38	20	17	14	105	22.5	M12x35	103.8	146.71	1.98	1.55	1.55	2.79	10.41
YGH45LC								128.8	171.2	28.9																125.3	191.85	2.63	2.68	2.68	3.69	
YGH55C	70	13	43.5	140	116	12	95	117.7	166.7	17.35	11	12.9	M14	17.5	26.5	12	19	53	44	23	20	16	120	30	M14x45	153.2	211.23	3.69	2.64	2.64	4.52	15.08
YGH55LC								155.8	204.8	36.4																184.9	276.23	4.88	4.57	4.57	5.96	
YGH65C	90	15	53.5	170	142	14	110	144.2	200.2	23.1	14	12.9	M16	25	37.5	15	15	63	53	26	22	18	150	35	M16x50	213.2	287.48	6.65	4.27	4.27	9.17	21.18
YGH65LC								203.6	259.6	52.8																277.8	420.17	9.38	7.38	7.38	12.89	

Note : 1 kgf= 9.81 N

YG Series Heavy Load Ball Type

(4) Dimensions for YGR-T(Rail Mounting from Bottom)

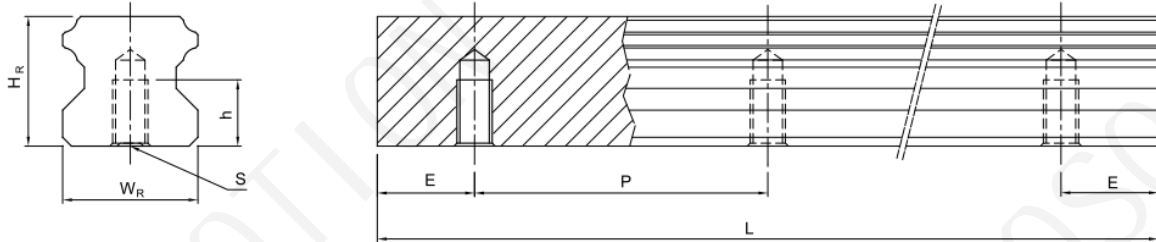

Model No.	Dimensions of Rail (mm)						Weight
	W _R	H _R	S	h	P	E	(kg/m)
YGR15T	15	15	M5x0.8P	8	60	20	1.48
YGR20T	20	17.5	M6x1P	10	60	20	2.29
YGR25T	23	22	M6x1P	12	60	20	3.35
YGR30T	28	26	M8x1.25P	15	80	20	4.67
YGR35T	34	29	M8x1.25P	17	80	20	6.51
YGR45T	45	38	M12x1.75P	24	105	22.5	10.87
YGR55T	53	44	M14x2P	24	120	30	15.67
YGR65T	63	53	M20x2.5P	30	150	35	21.73

YOSO MOTION LINEAR GUIDE RAIL

YSR Series Low Profile Ball Type

■ YSR Series - Low Profile Ball Type Linear Guideway

2-2-1 Features of the YSR Series Linear Guideway

The design of the YSR series offers a low profile, high load capacity, and high rigidity, it also features an equal load rating in all four directions and self-aligning capability to absorb installation error, allowing for higher accuracies. Additionally, the lower assembly height and the shorter length make the YSR series more suitable for high-speed automation machines and applications where space is limited.

The retainer is designed to hold the balls in the block even when it is removed from the rail.

2-2-2 Construction of YSR Series

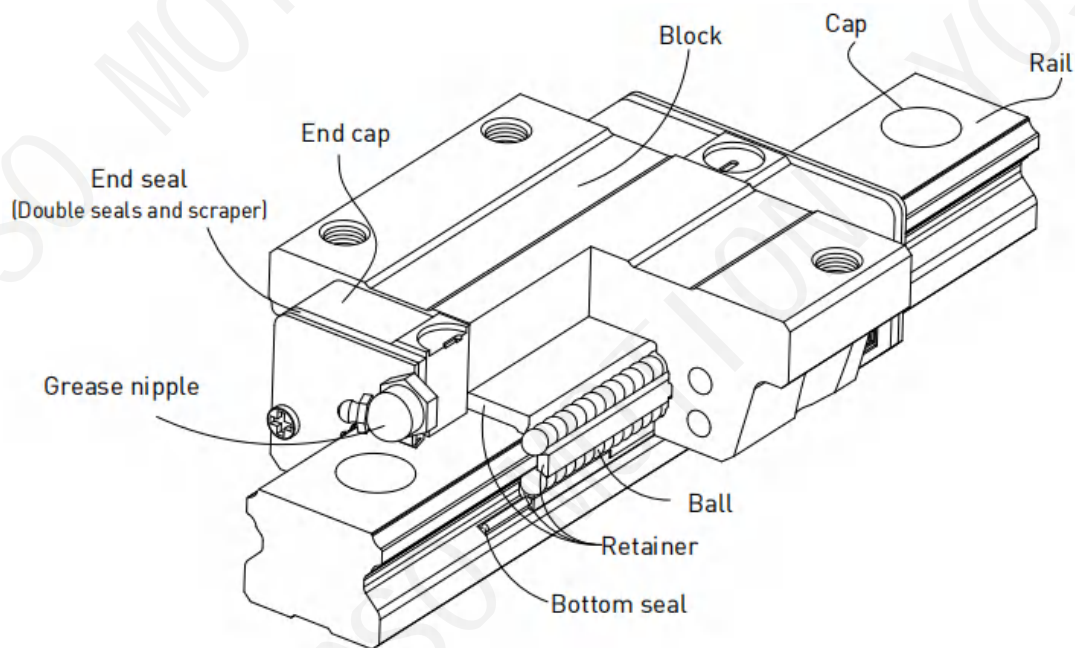

- Rolling circulation system: Block, rail, end cap and retainer
- Lubrication system: Grease nipple and piping Joint
- Dust protection system: End seal, bottom seal, cap and scraper

2-2-3 Model Number of YSR Series

YSR series linear guideways are classified into non-interchangeable and interchangeable types. The sizes of these two types are the same as one another. The main difference is that the interchangeable type of blocks and rails can be freely exchanged and they can maintain P-class accuracy. Because of strict dimensional control, the interchangeable type linear guideways are a wise choice for customers when rails do not need to be matched for an axis. The model number of the YSR series identifies the size, type, accuracy class, preload class, etc.

YSR Series Low Profile Ball Type

2-2-3 Model Number of YSR Series

YSR series linear guideways are classified into non-interchangeable and interchangeable types. The sizes of these two types are the same as one another. The main difference is that the interchangeable type of blocks and rails can be freely exchanged and they can maintain P-class accuracy. Because of strict dimensional control, the interchangeable type linear guideways are a wise choice for customers when rails do not need to be matched for an axis. The model number of the YSR series identifies the size, type, accuracy class, preload class, etc.

(1) Non-interchangeable type

Y S R 20 L C/R - 2 - - 1200 - N - Z0 - II - U + N3 N3

① ② ③ ④ ⑤ ⑥ ⑦ ⑧ ⑨ ⑩ ⑪ ⑫ ⑬ ⑭ ⑮

① Nominal Model	② Block Type	③ Height of Assembly Type	④ Dimension
Y	G:Standard S:Low-Assembly	R:Low-Assembly L:Middle-Assembly H:High-Assembly	15,20,25,30,35

⑤ Length of Block	⑥ Flange Type	⑦ Number of Block Per Rail	⑧ Accessory Code
N:Normal L:Long	C:With Flange R:Quartet	EX:2	□:Standard (Please refer to page A26)

⑨ Length of Rail	⑩ Accuracy Grade	⑪ Preload	⑫ Two Sets per Axis	⑬ Rail Special Machining
Unit:mm	N:Normal H:High P:Precision SP:Super-Precision UP:Ultra-Precision	ZF:Slight Clearance Z0:No Preload Z1:Light Preload Z2:Medium Preload Z3:Heavy Preload	II	U:Tapped-Hole Rail E:Rail with Special Machining

⑭ Block Surface Treatment	⑮ Rail Surface Treatment
S:Standard	S:Standard
B1:Black Oxidation	B1:Black Oxidation
N1:Hard Chrome Plating	N1:Hard Chrome Plating
P:Phosphating	P:Phosphating
N3:Nickel Plating	N3:Nickel Plating
N4:Raydent	N4:Raydent
N5:Chrome Plating	N5:Chrome Plating

No symbol required when plating is not needed

YOSO MOTION LINEAR GUIDE RAIL

YSR Series Low Profile Ball Type

2-2-4 Types

(1) Block types

YOSO offers two types of linear guideways, flange and square types.

Table 2-1-26 Rail Standard Length and Max. Length

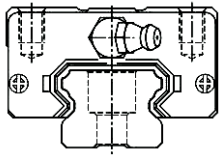
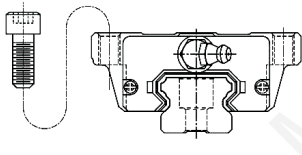
Type	Model	Shape	Height	Rail Length	Main Application
Standard	YSR-R		24	100	<ul style="list-style-type: none"> ● Machine Centers. ● NC Lathes. ● Grinding Machines ● Precision Machining Machines ● Heavy Cutting Machines ● Automation Devices ● Transportation Equipment ● Measuring Equipment ● Devices Requiring High Positional Accuracy
	YSR-LR		48	4000	
Flange	YSR-C		24	100	
	YSR-LC		48	4000	

*Please refer to the chapter 2-2-13 for the dimensional detail.

(2) Rail types

Besides the standard top mounting type, YOSO also offers bottom mounting type rails.

Table 2-1-2 Rail Types

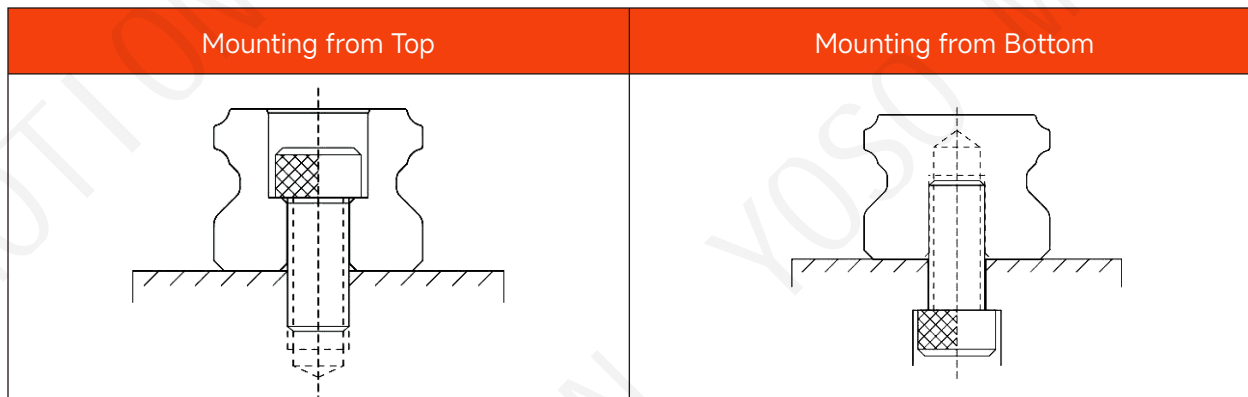

YSR Series Low Profile Ball Type

2-2-5 Accuracy

The accuracy of the YSR series can be classified into 5 classes: normal (C), high (H), precision (P), super-precision (SP), and ultra precision (UP). Choose the class by referencing the accuracy of selected equipment.

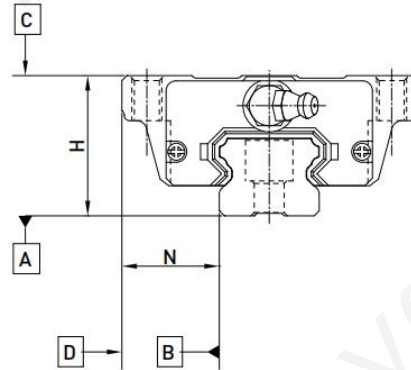

(1) Accuracy of non-interchangeable guideways

Table 2-2-3 Accuracy Standards

Item	YSR-15,20				
	Normal	High	Precision	Super Precision	Ultra Precision
	(C)	(H)	(P)	(SP)	(UP)
Dimensional tolerance of height H	±0.1	±0.03	0 -0.03	0 -0.015	0 -0.008
Dimensional tolerance of width N	±0.1	±0.03	0 -0.03	0 -0.015	0 -0.008
Variation of height H	0.02	0.01	0.006	0.004	0.003
Variation of width N	0.02	0.01	0.006	0.004	0.003
Running parallelism of block surface C to surface A	See Table 2-2-7				
Running parallelism of block surface D to surface B	See Table 2-2-7				

Table 2-2-4 Accuracy Standards

Item	YSR-25,30,35				
	Normal	High	Precision	Super Precision	Ultra Precision
	(C)	(H)	(P)	(SP)	(UP)
Dimensional tolerance of height H	±0.1	±0.04	0 -0.04	0 -0.02	0 -0.01
Dimensional tolerance of width N	±0.1	±0.04	0 -0.04	0 -0.02	0 -0.01
Variation of height H	0.02	0.015	0.007	0.005	0.003
Variation of width N	0.02	0.015	0.007	0.005	0.003
Running parallelism of block surface C to surface A	See Table 2-2-7				
Running parallelism of block surface D to surface B	See Table 2-2-7				

YOSO MOTION LINEAR GUIDE RAIL

YSR Series Low Profile Ball Type

(2) Accuracy of interchangeable guideways

Table 2-2-5 Accuracy Standards

Item	YSR-15,20		
	Normal	High	Precision
	(C)	(H)	(P)
Dimensional tolerance of height H	±0.1	±0.03	±0.015
Dimensional tolerance of width N	±0.1	±0.03	±0.015
Variation of height H	0.02	0.01	0.006
Variation of width N	0.02	0.01	0.006
Running parallelism of block surface C to surface A	See Table 2-2-7		
Running parallelism of block surface D to surface B	See Table 2-2-7		

Table 2-2-6 Accuracy Standards

Item	YSR-15,20		
	Normal	High	Precision
	(C)	(H)	(P)
Dimensional tolerance of height H	±0.1	±0.04	±0.02
Dimensional tolerance of width N	±0.1	±0.04	±0.02
Variation of height H	0.02	0.015	0.007
Variation of width N	0.03	0.015	0.007
Running parallelism of block surface C to surface A	See Table 2-2-7		
Running parallelism of block surface D to surface B	See Table 2-2-7		

(2) Accuracy of running parallelism

Table 2-2-7 Accuracy of Running Parallelism

Rail Length (mm)	Accuracy (μm)				
	C	h	p	SP	UP
100	12	7	3	2	2
100~200	14	9	4	2	2
200~300	15	10	5	3	2
300~500	17	12	6	3	2
500~700	20	13	7	4	2
700~900	22	15	8	5	3
900~1,100	24	16	9	6	3
1,100~1,500	26	18	11	7	4
1,500~1,900	28	20	13	8	4
1,900~2,500	31	22	15	10	5
2,500~3,100	33	25	18	11	6
3,100~3,600	36	27	20	14	7
3,600~4,000	37	28	21	15	7

YSR Series Low Profile Ball Type

2-2-6 Preload

(1) Definition

A preload can be applied to each guideway. Generally, a linear motion guideway has a negative clearance between the groove and balls in order to improve stiffness and maintain high precision. The figure shows that adding a preload can improve stiffness of the linear guideway. A preload no greater than ZA would be recommended for model sizes smaller than YSR20. This will avoid an over-loaded condition that would affect guideway life.

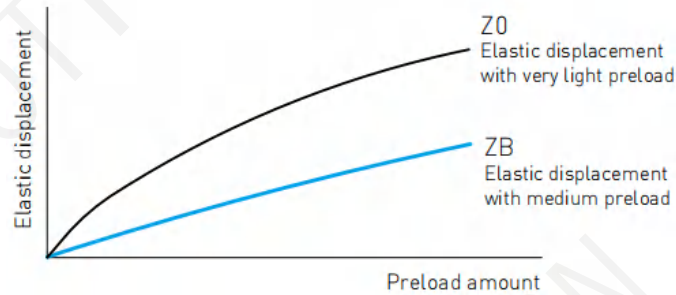

(2) Preload classes

YOSO offers three standard preloads for various applications and conditions.

Table 2-2-8 Preload Classes

Class	Code	Preload	Condition
Very Light Preload	Z0	0~0.02C	Certain load direction, low impact, low precision required
Light Preload	ZA	0.03C~0.05C	low load and high precision required
Medium Preload	ZB	0.06C~0.08C	High rigidity required, with vibration and impact

Class	Interchangeable Guideway	Non-Interchangeable Guideway
Preload classes	Z0, ZA	Z0, ZA, ZB

Note: The C in the preload column denotes basic dynamic load rating.

(3) Stiffness performance

Stiffness depends on preload. The following table shows stiffness value of each size

Table 2-2-9 Radial stiffness for YSR series

Load type	Series/Size	Stiffness (N/μm)		
		Z0	ZA	ZB
Medium load	YSR 15S	87	186	246
	YSR 20S	114	267	369
	YSR 25S	138	307	415
	YSR 30S	166	335	447
	YSR 35S	189	369	492
Heavy load	YSR 15C	141	323	429
	YSR 20C	181	444	615
	YSR 25C	219	510	668
	YSR 30C	265	555	745
	YSR 35C	307	615	816

YOSO MOTION LINEAR GUIDE RAIL

YSR Series Low Profile Ball Type

2-2-7 Lubrication

(1) Grease

- Grease nipple

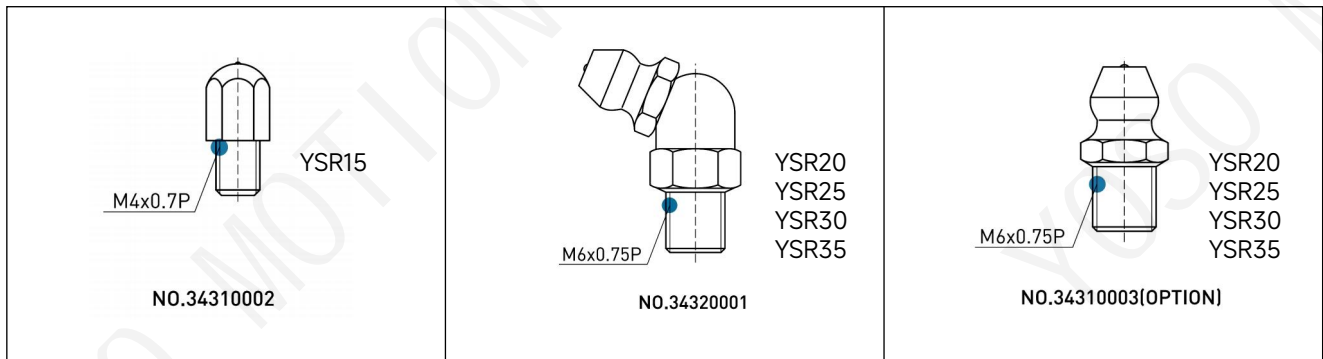

- Mounting location

The standard location of the grease fitting is at both ends of the block, the nipple may be mounted in the side or top of the block. For lateral installation, we recommend that the nipple be mounted to the non-reference side, otherwise please contact us. When lubricating from above, in the recess for the O-ring, a smaller, preformed recess can be found. Preheat the 0.8 mm diameter metal tip. Carefully open the small recess with the metal tip and pierce through it. Insert a round sealing ring into the recess. [The round sealing ring is not supplied with the block] Do not open the small recess with a drill bit this may introduce the danger of contamination. It is possible to carry out the lubrication by using the oil-piping joint.

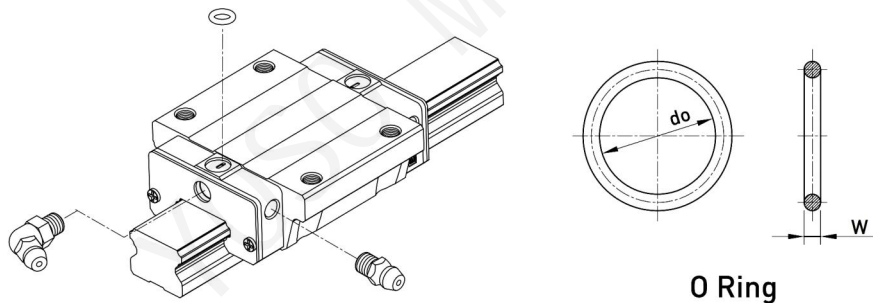

Table 2-2-10 O-Ring size and max. permissible depth for piercing

Size	O-Ring		Lube hole at top: max. permissible depth for piercing
	do(mm)	W(mm)	T _{max} (mm)
YSR15	2.5±0.15	1.5±0.15	6.9
YSR20	4.5±0.15	1.5±0.15	8.4
YSR25	4.5±0.15	1.5±0.15	10.4
YSR30	4.5±0.15	1.5±0.15	10.4
YSR35	4.5±0.15	1.5±0.15	10.8

The diagram on the right shows a cross-section of the rail block with a grease nipple being inserted into a lube hole. The hole has a diameter of 0.8 mm. The maximum permissible depth for piercing is labeled as T_{max}.

YSR Series Low Profile Ball Type

- The oil amount for a block filled with grease

Table 2-2-11 The oil amount for a block filled with grease

Size	Medium Load	Heavy Load
	(cm ³)	(cm ³)
YSR15	0.8	1.4
YSR20	1.5	2.4
YSR25	2.8	4.6
YSR30	3.7	6.3
YSR35	5.6	6.6

- Frequency of replenishment

Check the grease every 100 km, or every 3-6 months.

(2) Oil

The recommended viscosity of oil is about 32~150cSt. If you need to use oil-type lubrication, please inform us.

- Types of oil piping joint

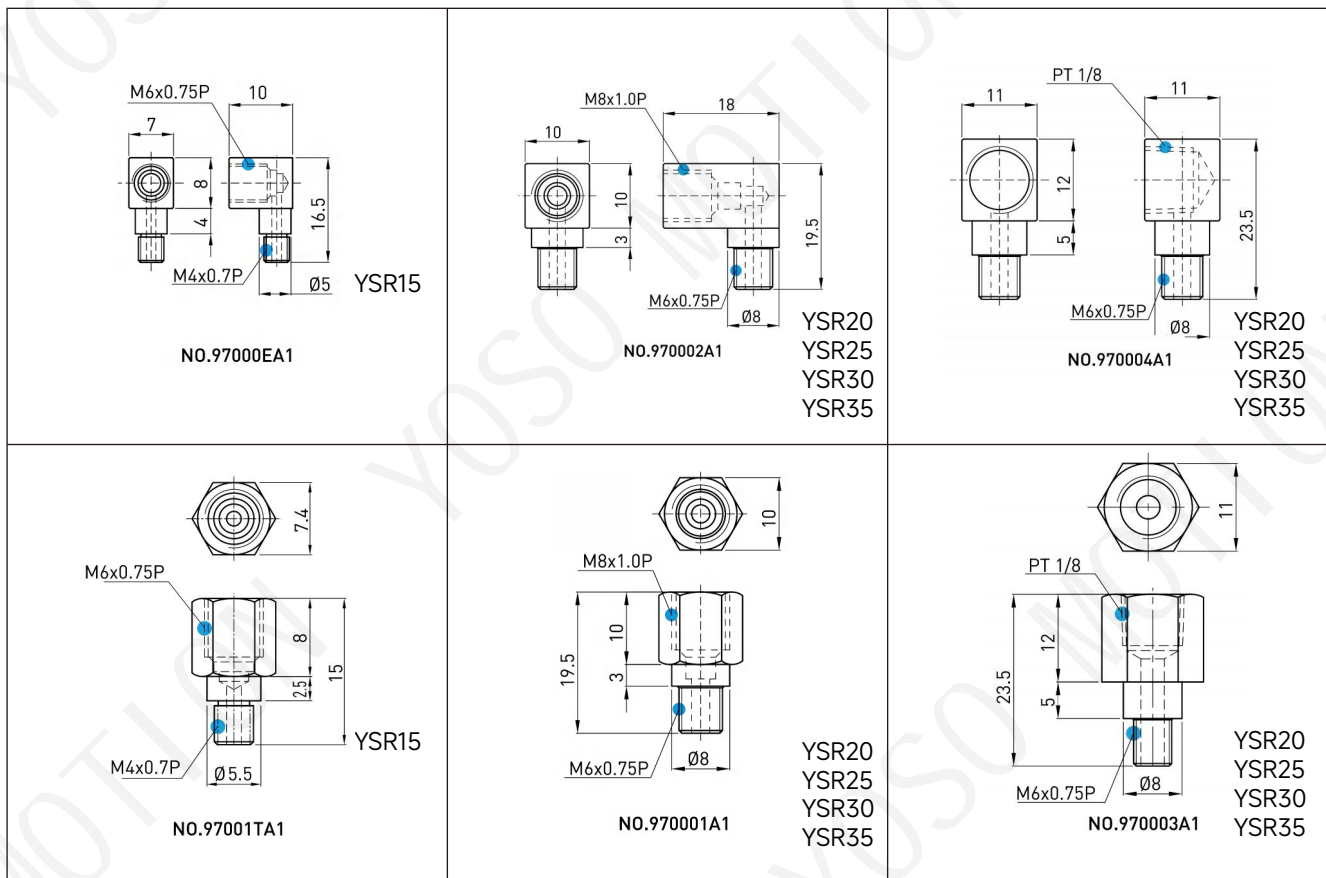

- Types of oil piping joint

Table 2-2-11 The oil amount for a block filled with grease

Size	feed rate (cm ³ /hr)	Size	feed rate (cm ³ /hr)
YSR15	0.1	YSR30	0.2
YSR20	0.133	YSR35	0.233
YSR25	0.167		

YOSO MOTION LINEAR GUIDE RAIL

YSR Series Low Profile Ball Type

2-2-8 Dust Protection Equipment

(1) Codes of equipment

If the following equipment is needed, please indicate the code followed by the model number.

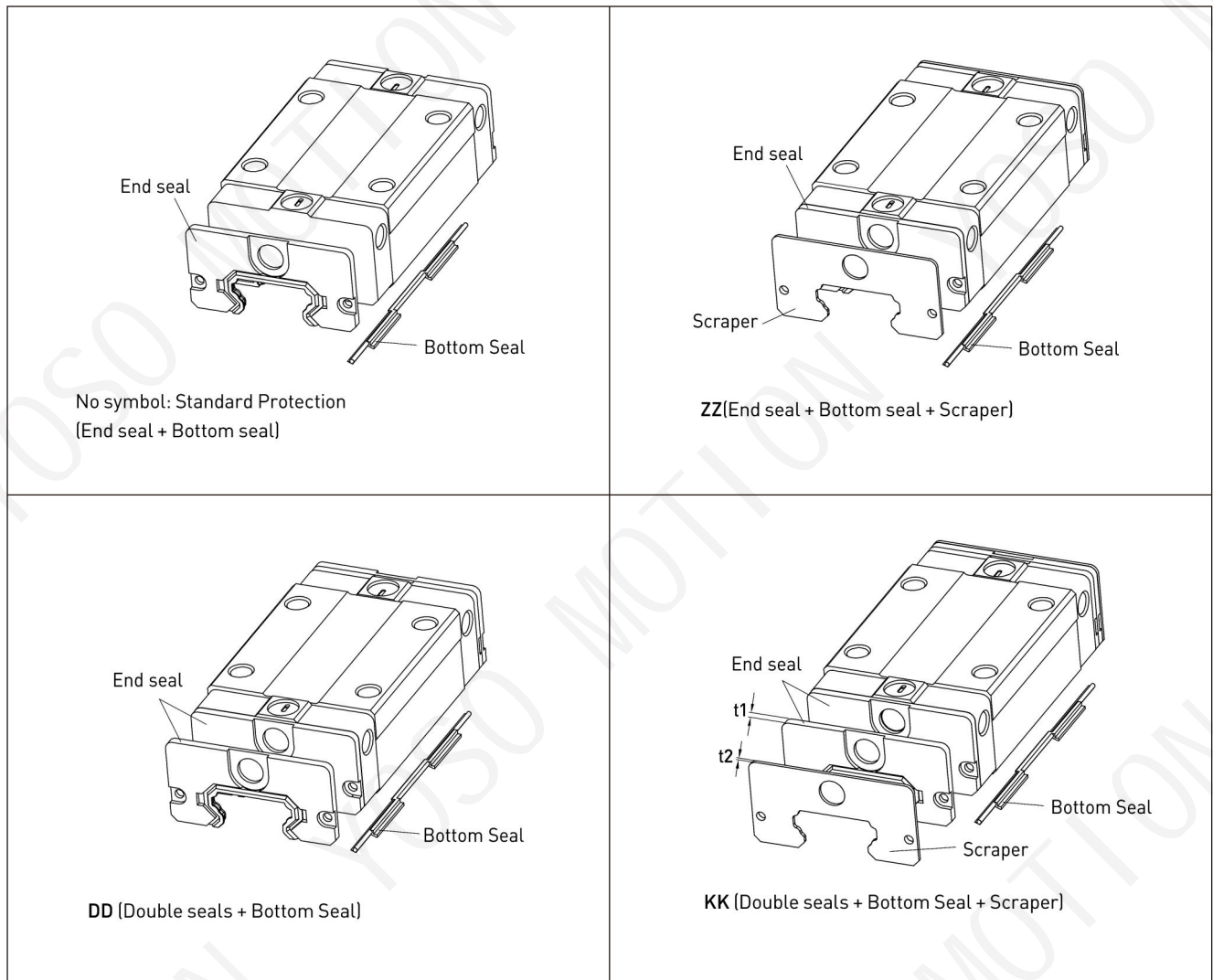

(2) End seal and bottom seal

Protects against contaminants entering the block. Reduces potential for groove damage resulting in a reduction of liferatings.

(3) Double seals

Removing foreign matters from the rail to prevent contaminants from entering the block

Table 2-2-13 Dimensions of end seal

Size	Thickness (t1) (mm)	Size	Thickness (t1) (mm)
YSR15ES	2	YSR30ES	2
YSR20ES	2	YSR35ES	2
YSR25ES	2		

YSR Series Low Profile Ball Type

(4) Scraper

Clears larger contaminants, such as weld spatter and metal cuttings, from the rail. Metal scraper protects end seals from excessive damage,

Table 2-2-14 Dimensions of Scraper

Size	Thickness (t2) (mm)	Size	Thickness (t2) (mm)
YSR15SC	0.8	YSR30SC	1
YSR20SC	0.8	YSR35SC	1.5
YSR25SC	1		

(5) Bolt caps for rail mounting holes

Rail mounting hole caps prevent foreign matter from accumulating in the mounting holes. Caps are included with the rail package.

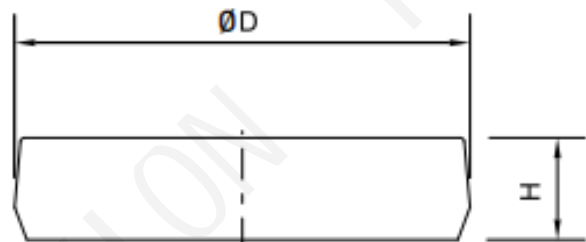

Table 2-2-15 Dimensions of Bolt Caps for Rail Mounting Holes

Rail size	Bolt size	Diameter(D) (mm)	Thickness(H) (mm)
YSR15R	M3	6.15	1.2
YSR20R	M5	9.65	2.5
YSR25R	M6	11.15	2.5
YSR30R	M6	11.15	2.5
YSR35R	M8	14.20	3.5
YSR15U	M4	7.65	1.1
YSR30U	M8	14.20	3.5

(6) Dimensions of block equipped with the dustproof parts

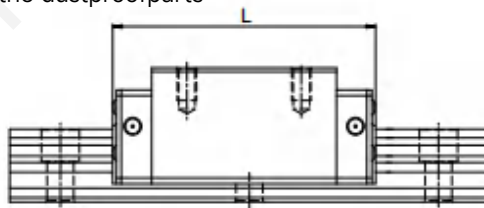

Table 2-2-16 Overall block length

Rail size	Overall block length(L)			
	SS	ZZ	DD	KK
YSR15S	40.1(42.5)	41.7(46.1)	44.1(46.5)	45.7(50.1)
YSR15C	56.8(59.2)	58.4(62.8)	60.8(63.2)	62.4(66.8)
YSR20S	50.0(54.0)	51.6(57.6)	54.0(58.0)	55.6(61.6)
YSR20C	69.1(73.1)	70.7(76.7)	73.1(77.1)	74.7(80.7)
YSR25S	59.1(63.1)	61.1(67.1)	63.1(67.1)	65.1(71.1)
YSR25C	82.6(86.6)	84.6(90.6)	86.6(90.6)	88.6(94.6)
YSR30S	69.5(73.5)	71.5(77.5)	73.5(77.5)	75.5(81.5)
YSR30C	98.1(102.1)	100.1(106.1)	102.1(106.1)	104.1(110.1)
YSR35S	75.0(79.0)	78.0(84.0)	79.0(83.0)	82.0(88.0)
YSR35C	108.0(112.0)	111.0(117.0)	112.0(116.0)	115.0(121.0)

Note : The marking of "0" denotes the maximum block length with screws, lips of end seals, etc.

YOSO MOTION LINEAR GUIDE RAIL

YSR Series Low Profile Ball Type

2-2-9 Friction

The maximum value of resistance per end seal are as shown in the table.

Table 2-2-17 Seal Resistance

Size	Resistance N(kgf)
YSR15	1.47(0.15)
YSR20	1.96(0.2)
YSR25	1.96(0.2)
YSR30	2.45(0.25)
YSR35	1.96(0.2)

Note: 1. 1kgf=9.81N

2. Please inform YOSO if low friction request is required.

2-2-10 Mounting Surface Accuracy Tolerance

Because of the circular-arc contact design, the YSR linear guideway can withstand surface-error installation and deliver smooth linear motion. When the mounting surface meets the accuracy requirements of the installation, the high accuracy and rigidity of the guideway will be obtained without any difficulty. For faster installation and smoother movement, YOSO offers a preload with normal clearance because of its ability to absorb higher deviations in mounting surface inaccuracies.

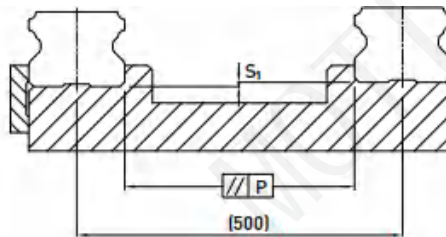

Table 2-2-18 Max. Parallelism Tolerance (P)

Size	Preload classes		
	Z0	ZA	ZB
YSR15	25	18	-
YSR20	25	20	18
YSR25	30	22	20
YSR30	40	30	27
YSR35	50	35	30

Table 2-2-19 Max. Tolerance of Reference Surface Height (S₁)

Size	Preload classes		
	Z0	ZA	ZB
YSR15	130	85	-
YSR20	130	85	50
YSR25	130	85	70
YSR30	170	110	90
YSR35	210	150	120

Note: Permissible value is proportional to the axial distance

YSR Series Low Profile Ball Type

2-2-11 Cautions for Installation

(1) Shoulder heights and chamfers

Improper shoulder heights and fillets of mounting surfaces will cause a deviation in accuracy and the interference with the rail or block. As long as the recommended shoulder heights and fillets are followed, installation inaccuracies should be eliminated.

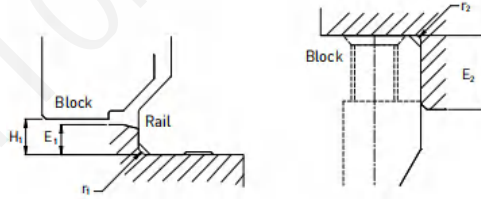

Table 2-2-20 Shoulder Heights and chamfers

Size	Max.radius of fillets	Max.radius of fillets	Shoulder height beside the rail	Shoulder height beside the block	Clearance under block
	r_1 (mm)	r_2 (mm)	E_1 (mm)	E_2 (mm)	H_1 (mm)
YSR15	0.5	0.5	2.7	5.0	4.5
YSR20	0.5	0.5	5.0	7.0	6.0
YSR25	1.0	1.0	5.0	7.5	7.0
YSR30	1.0	1.0	7.0	7.0	10.0
YSR35	1.0	1.0	7.5	9.5	11.0

(2) Tightening Torque of Bolts for installation

Improperly tightened mounting bolts will seriously affect the accuracy of linear guide installations. The following tightening torques for different sizes of bolts are recommended.

Table 2-2-20 Shoulder Heights and chamfers

Size	Bolt size	Torque N-cm(kgf-cm)		
		Iron	Casting	Aluminum
YSR15	M3×0.5P×16L	186(19)	127(13)	98(10)
YSR20	M5×0.8P×16L	883(90)	588(60)	441(45)
YSR25	M6×1P×20L	1373(140)	921(94)	686(70)
YSR30	M6×1P×25L	1373(140)	921(94)	686(70)
YSR35	M8×1.25P×25L	3041(310)	2010(205)	1470(150)

Note: 1 kgf= 9.81 N

YOSO MOTION LINEAR GUIDE RAIL

YSR Series Low Profile Ball Type

2-2-12 Standard and Maximum Lengths of Rail

YOSO offers a number of standard rail lengths. Standard rail lengths feature end mounting hole placements set to predetermined values (E). For non-standard rail lengths, be sure to specify the E-value to be no greater than 1/2 the pitch (P) dimension. An E-value greater than this will result in unstable rail ends.

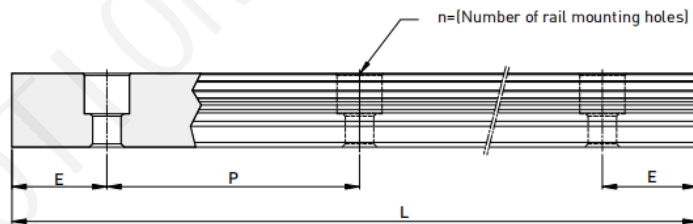

$$L = (n-1) \times P + 2 \times E \quad \text{Eq.2.2}$$

L : Total length of rail (mm)

n : Number of mounting holes

P : Distance between any two holes (mm)

E : Distance from the center of the last hole to the edge (mm)

Table 2-2-18 Max, Parallelism Tolerance (P)

Item	YSR15	YSR20	YSR25	YSR30	YSR35
Standard Length L(n)	160(3)	220(4)	220(4)	280(4)	280(4)
	220(4)	280(5)	280(5)	440(6)	440(6)
	280(5)	340(6)	340(6)	600(8)	600(8)
	340(6)	460(8)	460(8)	760(10)	760(10)
	460(8)	640(11)	640(11)	1,000(13)	1,000(13)
	640(11)	820(14)	820(14)	1,640(21)	1,640(21)
	820(14)	1,000(17)	1,000(17)	2,040(26)	2,040(26)
		1,240(21)	1,240(21)	2,520(32)	2,520(32)
	1,600(27)	1,600(27)	3,000(38)	3,000(38)	
Pitch(P)	60	60	60	80	80
Distance to End(Es)	20	20	20	20	20
Max.Standard Length	4,000(67)	4,000(67)	4,000(67)	3,960(50)	3,960(50)
Max.Length	4,000	4,000	4,000	4,000	4,000

Note :1. Tolerance of E value for standard rail is 0.5-0.5 mm. Tolerance of E value for jointed rail is 0-0.3 mm.

2. Maximum standard length means the max. rail length with standard E value on both sides.

3. If different E value is needed, please contact HIWIN.

4. EGR15 of stainless steel is supplied with the maximum length of 2000mm.

YSR Series Low Profile Ball Type

2-2-13 Dimensions for YOSO YSR Series

(1) YSR-R/YSR-LR

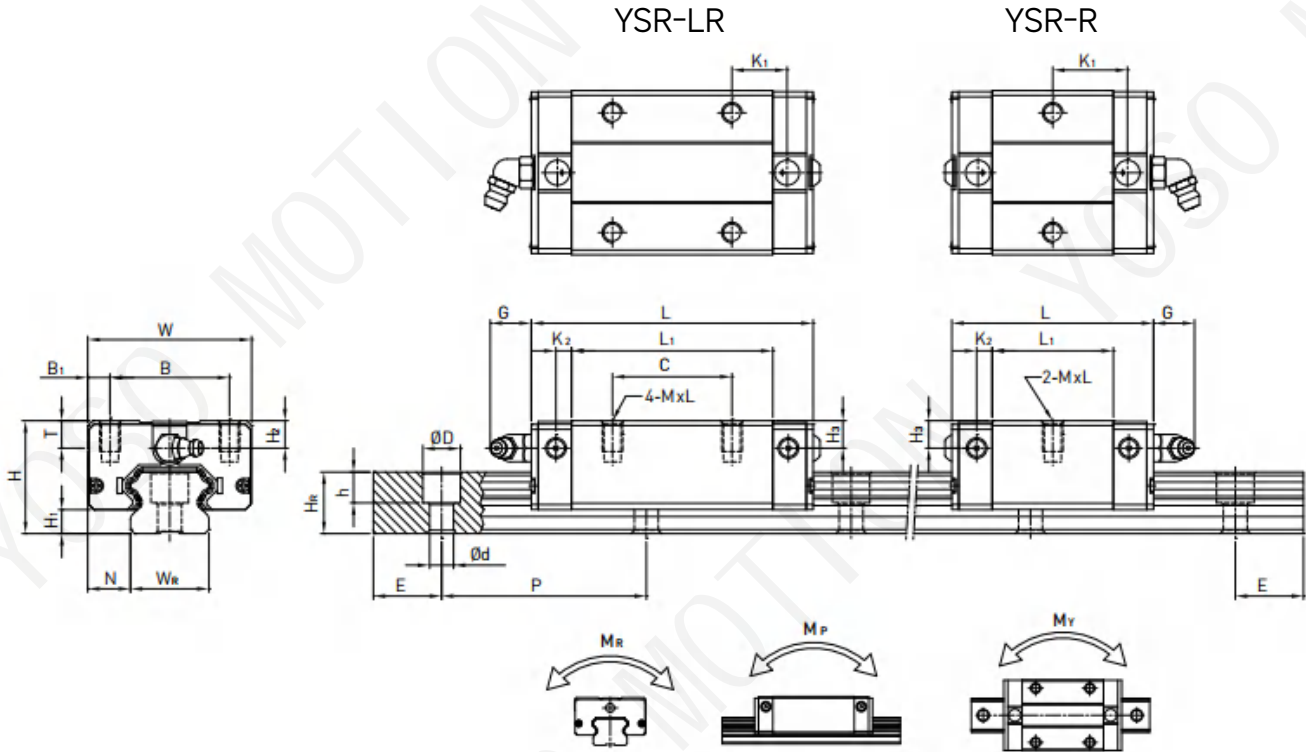

Model No.	Dimensions of Assembly (mm)			Dimensions of Block (mm)										Dimensions of Rail (mm)						Mounting Bolt for Rail (mm)	Basic Dynamic Load Rating C (kN)	Basic Static Load Rating C ₀ (kN)	Static Rated Moment			Weight						
	H	H ₁	N	W	B	B ₁	C	L ₁	L	K ₁	K ₂	G	MxL	T	H ₂	H ₃	W _n	H _a	D				h	d	P	E	M _R (kN-m)	M _P (kN-m)	M _Y (kN-m)	Block (kg)	Rail (kg/m)	
YSR15R	24	4.5	9.5	34	26	4	-	23.1	40.1	14.8	3.5	5.7	M4x6	6	5.5	6	15	12.5	6	4.5	3.5	60	20	M3x16	5.35	9.40	0.08	0.04	0.04	0.09	1.25	
YSR15LR							26	39.8	56.8	10.15															7.83	16.19	0.13	0.10	0.10	0.15		
YSR20R	28	6	11	42	32	5	-	29	50	18.75	4.15	12	M5x7	7.5	6	6	20	15.5	9.5	8.5	6	60	20	M5x16	7.23	12.74	0.13	0.06	0.06	0.15	2.08	
YSR20LR							32	48.1	69.1	12.3																						
YSR25R	33	7	12.5	48	35	6.5	-	35.5	59.1	21.9	4.55	12	M6x9	8	8	8	23	18	11	9	7	60	20	M6x20	11.40	19.50	0.23	0.12	0.12	0.25	2.67	
YSR25LR							35	59	82.6	16.15																						
YSR30R	42	10	16	60	40	10	-	41.5	69.5	26.75	6	12	M8x12	9	8	9	28	23	11	9	7	80	20	M6x25	16.42	28.10	0.40	0.21	0.21	0.45	4.35	
YSR30LR							40	70.1	98.1	21.05																						
YSR35R	48	11	18	70	50	20	-	45	75	28.5	7	12	M8x12	10	8.5	8.5	34	27.5	14	12	9	80	20	M8x25	22.66	37.38	0.56	0.31	0.31	0.74	6.14	
YSR35LR							50	78	108	20																						

Note : 1 kgf = 9.81 N

YOSO MOTION LINEAR GUIDE RAIL

YSR Series Low Profile Ball Type

(2) YSR-C/YSR-LC

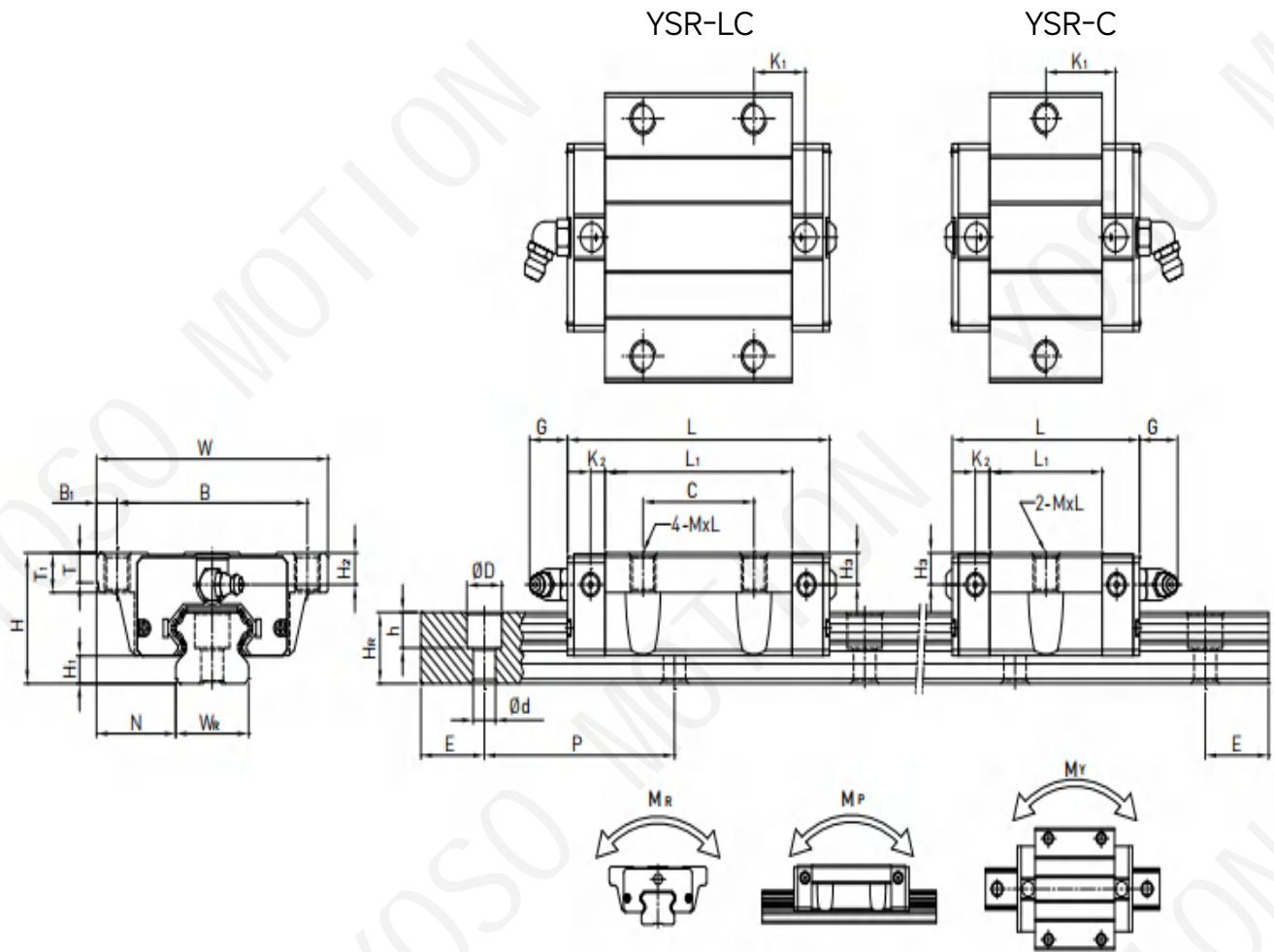

Model No.	Dimensions of Assembly (mm)			Dimensions of Block (mm)										Dimensions of Rail (mm)					Mounting Bolt for Rail (mm)	Basic Dynamic Load Rating C (kN)	Basic Static Load Rating C ₀ (kN)	Static Rated Moment			Weight							
	H	H _i	N	W	B	B _i	C	L ₁	L	K ₁	K ₂	G	M	T	T ₁	H ₂	H ₃	W _R				H _R	D	h	d	P	E	M _R (kN-m)	M _P (kN-m)	M _Y (kN-m)	Block (kg)	Rail (kg/m)
YSR15C	24	4.5	18.5	52	41	5.5	-	23.1	40.1	14.8	3.5	5.7	M5	5	7	5.5	6	15	12.5	6	4.5	3.5	60	20	M3x16	5.35	9.40	0.08	0.04	0.04	0.12	1.25
YSR15LC							26	39.8	56.8	10.15																						
YSR20C	28	6	19.5	59	49	5	-	29	50	18.75	4.15	12	M6	7	9	6	6	20	15.5	9.5	8.5	6	60	20	M5x16	7.23	12.74	0.13	0.06	0.06	0.19	2.08
YSR20LC																												32	48.1	69.1	12.3	
YSR25C	33	7	25	73	60	6.5	-	35.5	59.1	21.9	4.55	12	M8	7.5	10	8	8	23	18	11	9	7	60	20	M6x20	11.40	19.50	0.23	0.12	0.12	0.35	2.67
YSR25LC																												35	59	82.6	16.15	
YSR30C	42	10	31	90	72	9	-	41.5	69.5	26.75	6	12	M10	7	10	8	9	28	23	11	9	7	80	20	M6x25	16.42	28.10	0.40	0.21	0.21	0.62	4.35
YSR30LC																												40	70.1	98.1	21.05	
YSR35C	48	11	33	100	82	9	-	45	75	28.5	7	12	M10	10	13	8.5	8.5	34	27.5	14	12	9	80	20	M8x25	22.66	37.38	0.56	0.31	0.31	0.84	6.14
YSR35LC																												50	78	108	20	

Note : 1 kgf = 9.81 N

YEH Series Four-Row Wide Rail

■ YEH Series – Four-Row Wide Rail Linear Guideway

2-3-1 Features of the YEH Series Linear Guideway

The YE series features equal load ratings in the radial, reverse radial and the lateral direction with contact points at 45 degrees. This along with the wide rail, allows the guide way to be rated for high loads, moments and rigidity. By design, it has a self-aligning capacity that can absorb most installation errors and can meet high accuracy standards. The ability to use a single rail and to have the low profile with a low center of gravity is ideal where space is limited and/or high moments are required.

2-3-2 Construction of YEH Series

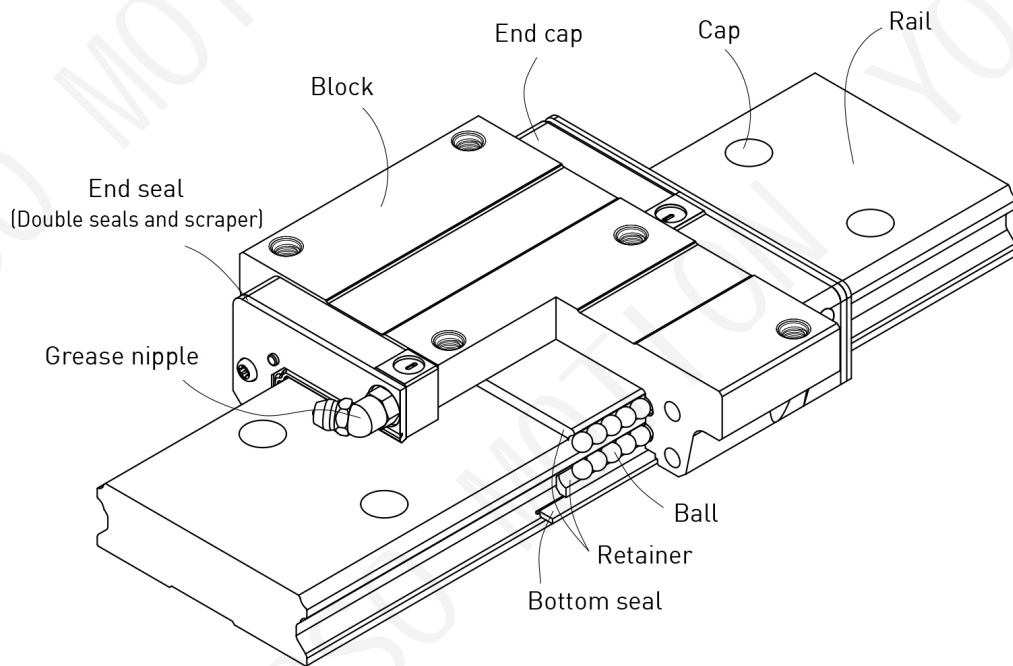

- Rolling circulation system: Block, rail, end cap and retainer
- Lubrication system: Grease nipple and piping Joint
- Dust protection system: End seal, bottom seal, cap and scraper

YEH Series Four-Row Wide Rail

2-3-3 Model Number of YEH Series

YEH series linear guideways are classified into non-interchangeable and interchangeable types. The sizes of these two types are the same as one another. The main difference is that the interchangeable type of blocks and rails can be freely exchanged and they can maintain P-class accuracy. Because of strict dimensional control, the interchangeable type linear guideways are a wise choice for customers when rails do not need to be matched for an axis. The model number of the YEH series identifies the size, type, accuracy class, preload class, etc.

YEH 21 L C/R - 2 - - 1200 - N - Z0 - II - U + N3 N3

①
②
③
④
⑤
⑥
⑦
⑧
⑨
⑩
⑪
⑫
⑬

①	②
Nominal Model	Dimension
YEH	17,21,27,35,50

③	④	⑤	⑥
Length of Block	Flange Type	Number of Block Per Rail	Accessory Code
N:Normal L:Long	C:WithFlange R:Quartet	EX:2	<input type="checkbox"/> :Standard (Please refer to page A26)

⑦	⑧	⑨	⑩	⑪
Length of Rai	Accuracy Grade	Preload	Two Sets per Axis	Rail Special Machining
Unit:mm	N:Norma H:High P:Precision SP:Super-Precision UP:Ultra-Precision	ZF:Slight Clearance Z0:No Preload Z1:Light Preload Z2:Medium Preload Z3:Heavy Preload	II	U:Tapped-Hole Rail E:Rail with Special Machining

⑫	⑬
Block Surface Treatment	Rail Surface Treatment
S:Standard	S:Standard
B1:Black Oxidation	B1:Black Oxidation
N1:Hard Chrome Plating	N1:Hard Chrome Plating
P:Phosphating	P:Phosphating
N3:Nickel Plating	N3:Nickel Plating
N4:Raydent	N4:Raydent
N5:Chrome Plating	N5:Chrome Plating

No symbol required when plating is not needed

YOSO MOTION LINEAR GUIDE RAIL

YEH Series Four-Row Wide Rail

2-3-4 Types

(1) Block types

YOSO offers two types of linear guideways, flange and square types.

Table 2-3-1 Block Types

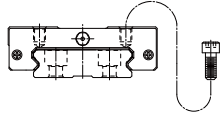
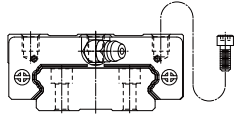
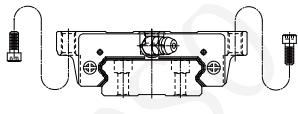
Type	Model	Shape	Height	Rail Length	Main Application
Standard	YEH-R 17, 21		17 ↓ 21	100 ↓ 4000	<ul style="list-style-type: none"> ● Automation drive ● High-speed transportation equipment ● Precision measuring equipment ● Semiconductor manufacturing equipment ● Blow Moulding machines ● Single Axis Robot-Robotics ● Single Axis Equipment with High Anti-rolling Requirement
Standard	YEH-R 27, 35, 50		27 ↓ 50	100 ↓ 4000	
Flange	YEH-C YEH-LC		27 ↓ 50	100 ↓ 4000	

(2) Rail types

Besides the standard top mounting type, YOSO also offers bottom mounting type rails.

Table 2-3-2 Rail Types

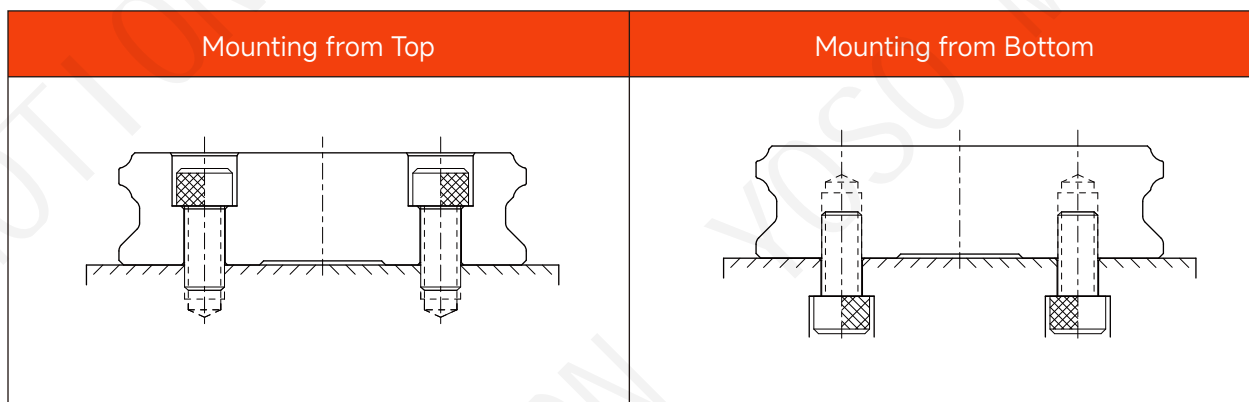

YEH Series Four-Row Wide Rail

2-3-4 Accuracy

The accuracy of the YEH series can be classified into 5 classes: normal(C), high(H), precision(P), super precision(SP), and ultra precision(UP). Choose the class by referencing the accuracy of selected equipment.

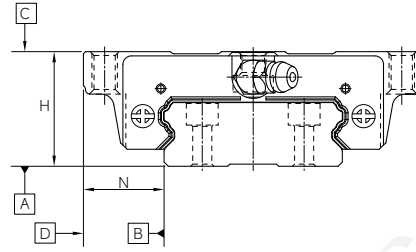

(1) Accuracy of non-interchangeable guideways

Table 2-3-3 Accuracy Standards

Unit:mm

Type	YEH-17, 21					YEH-27, 35				
	Normal	High	Precision	Super Precision	Ultra Precision	Normal	High	Precision	Super Precision	Ultra Precision
	(C)	(H)	(P)	(SP)	(UP)	(C)	(H)	(P)	(SP)	(UP)
Dimensional tolerance of height H	±0.1	±0.03	0 -0.03	0 -0.015	0 -0.008	±0.1	±0.04	0 -0.04	0 -0.02	0 -0.01
Dimensional tolerance of width N	±0.1	±0.03	0 -0.03	0 -0.015	0 -0.008	±0.1	±0.04	0 -0.04	0 -0.02	0 -0.01
Variation of height H	0.02	0.01	0.006	0.004	0.003	0.02	0.015	0.007	0.005	0.003
Variation of width N	0.02	0.01	0.006	0.004	0.003	0.03	0.015	0.007	0.005	0.003
Running parallelism of block surface C to surface A	See Table 2-3-5									
Running parallelism of block surface D to surface B	See Table 2-3-5									

Type	YEH-50				
Accuracy Classes	Normal	High	Precision	Super Precision	Ultra Precision
	(C)	(H)	(P)	(SP)	(UP)
Dimensional tolerance of height H	±0.1	±0.05	0 -0.05	0 -0.003	0 -0.02
Dimensional tolerance of width N	±0.1	±0.05	0 -0.05	0 -0.003	0 -0.02
Variation of height H	0.03	0.015	0.007	0.005	0.003
Variation of width N	0.03	0.02	0.01	0.007	0.005
Running parallelism of block surface C to surface A	See Table 2-3-5				
Running parallelism of block surface D to surface B	See Table 2-3-5				

(1) Accuracy of interchangeable guideways

Table 2-3-4 Accuracy Standards

Unit:mm

Type	YEH-17, 21			YEH-27, 35			YEH-50		
Accuracy Classes	Normal (C)	High (H)	Precision (P)	Normal (C)	High (H)	Precision (P)	Normal (C)	High (H)	Precision (P)
Dimensional tolerance of height H	±0.1	±0.03	±0.015	±0.1	±0.04	±0.02	±0.1	±0.05	±0.025
Dimensional tolerance of width N	±0.1	±0.03	±0.015	±0.1	±0.04	±0.02	±0.1	±0.05	±0.025
Variation of height H	0.02	0.01	0.006	0.02	0.015	0.007	0.03	0.015	0.007
Variation of width N	0.02	0.01	0.006	0.03	0.015	0.007	0.03	0.02	0.01
Running parallelism of block surface C to surface A	See Table 2-3-5								
Running parallelism of block surface D to surface B	See Table 2-3-5								

YOSO MOTION LINEAR GUIDE RAIL

YEH Series Four-Row Wide Rail

(3) Accuracy of running parallelism

Table 2-3-5 Accuracy of Running Parallelism

Rail Length (mm)	Accuracy (μm)				
	C	H	p	SP	UP
~100	12	7	3	2	2
100~200	14	9	4	2	2
200~300	15	10	5	3	2
300~500	17	12	6	3	2
500~700	20	13	7	4	2
700~900	22	15	8	5	3
900~1,100	24	16	9	6	3
1,100~1,500	26	18	11	7	4
1,500~1,900	28	20	13	8	4
1,900~2,500	31	22	15	10	5
2,500~3,100	33	25	18	11	6
3,100~3,600	36	27	20	14	7
3,600~4,000	37	28	21	15	7

2-3-6 Preload

(1) Definition

A preload can be applied to each guideway. Generally, a linear motion guideway has a negative clearance between the groove and balls in order to improve stiffness and maintain high precision. The figure shows that adding a preload can improve stiffness of the linear guideway.

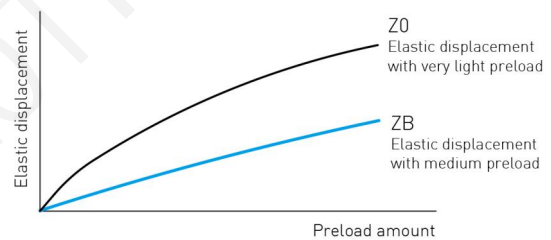

(2) Preload classes

YOSO offers three standard preloads for various applications and conditions.

Table 2-3-6 Preload Classes

Class	Code	Preload	Condition
Very Light Preload	Z0	0~0.02C	Certain load direction, low impact, low precision required
Light Preload	ZA	0.03C~0.05C	low load and high precision required
Medium Preload	ZB	0.06C~0.08C	High rigidity required, with vibration and impact

Class	Interchangeable Guideway	Non-Interchangeable Guideway
Preload classes	Z0,ZA	Z0,ZA,ZB

Note: The C in the preload column denotes basic dynamic load rating.

(3) Stiffness performance

Stiffness depends on preload. The following table shows stiffness value of each size

Table 2-3-7 Radial stiffness for YEH series

Load type	Series/Size	Stiffness (N/ μm)		
		Z0	ZA	ZB
Medium load	YEH 17C	130	342	469
	YEH 21C	153	368	497
	YEH 27C	188	476	651
	YEH 35C	285	607	804
	YEH 50C	429	758	1042

YEH Series Four-Row Wide Rail

2-3-7 Lubrication

(1) Grease

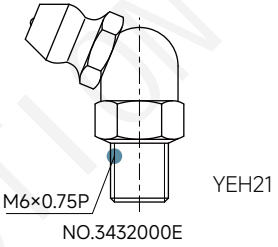
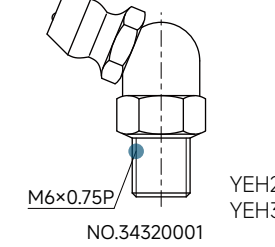
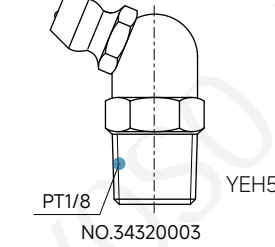
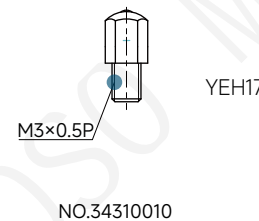
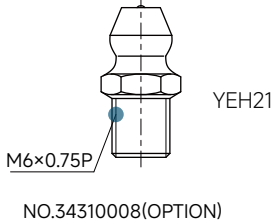
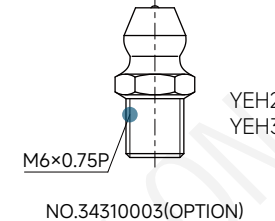
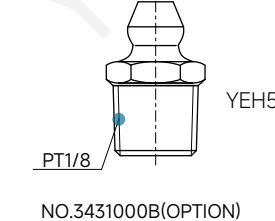
● Grease nipple	 YEH21 M6×0.75P NO.3432000E	 YEH27 YEH35 M6×0.75P NO.34320001	 YEH50 PT1/8 NO.34320003
 YEH17 M3×0.5P NO.34310010	 YEH21 M6×0.75P NO.34310008(OPTION)	 YEH27 YEH35 M6×0.75P NO.34310003(OPTION)	 YEH50 PT1/8 NO.3431000B(OPTION)

● Mounting location

The standard location of the grease fitting is at both ends of the block, the nipple may be mounted in the side or top of the block. For lateral installation, we recommend that the nipple be mounted to the non-reference side, otherwise please contact us. When lubricating from above, in the recess for the O-ring, a smaller, preformed recess can be found. Preheat the 0.8 mm diameter metal tip. Carefully open the small recess with the metal tip and pierce through it. Insert a round sealing ring into the recess. (The round sealing ring is not supplied with the block) Do not open the small recess with a drill bit this may introduce the danger of contamination. It is possible to carry out the lubrication by using the oil-piping joint.

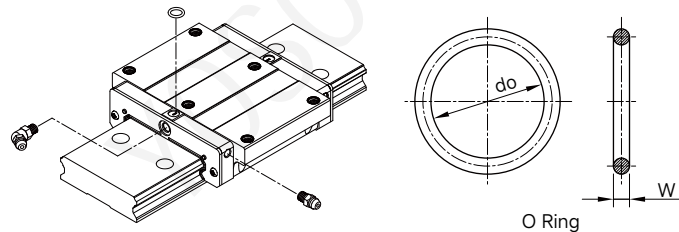
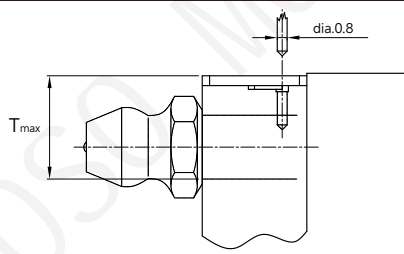

Table 2-3-8 O-Ring size and max. permissible depth for piercing

Size	O-Ring		Lube hole at top: max. permissible depth for piercing
	d_o (mm)	W (mm)	T_{max} (mm)
YEH21	2.5 ± 0.15	1.5 ± 0.15	4.2
YEH27	4.5 ± 0.15	1.5 ± 0.15	5.8
YEH35	4.5 ± 0.15	1.5 ± 0.15	7.6
YEH50	4.5 ± 0.15	1.5 ± 0.15	11.8



The diagram shows a cross-section of the rail block with a lube hole at the top. The diameter of the hole is labeled as $\text{dia.}0.8$ and the depth is labeled as T_{max} .

● The oil amount for a block filled with grease

Table 2-3-9 The oil amount for a block filled with grease

Size	Heavy Load (cm ³)	Size	Heavy Load (cm ³)
YEH17	1.4	YE35	9.5
YEH21	2.4	YE50	20
YEH27	3.6		

● Frequency of replenishment

Check the grease every 100 km, or every 3-6 months.

YOSO MOTION LINEAR GUIDE RAIL

YEH Series Four-Row Wide Rail

(2) Oil

The recommended viscosity of oil is about 30~150cSt. If you need to use oil-type lubrication, please inform us.

<p>YEH27 YEH35</p> <p>NO.970002A1</p>	<p>YEH50</p> <p>NO.970006A1</p>
<p>YEH27 YEH35</p> <p>NO.970004A1</p>	<p>YEH50</p> <p>NO.970008A1</p>
<p>YEH27 YEH35</p> <p>NO.970001A1</p>	<p>YEH50</p> <p>NO.970005A1</p>
<p>YEH27 YEH35</p> <p>NO.970003A1</p>	<p>YEH50</p> <p>NO.970007A1</p>

YEH Series Four-Row Wide Rail

● Oil feeding rate

Table 2-3-10 oil feed rate

Size	feed rate (cm ³ /hr)
YEH17	0.15
YEH21	0.2
YEH27	0.2
YEH35	0.3
YEH50	0.4

2-3-8 Dust Protection Equipment

(1) Codes of equipment

If the following equipment is needed, please indicate the code followed by the model number.

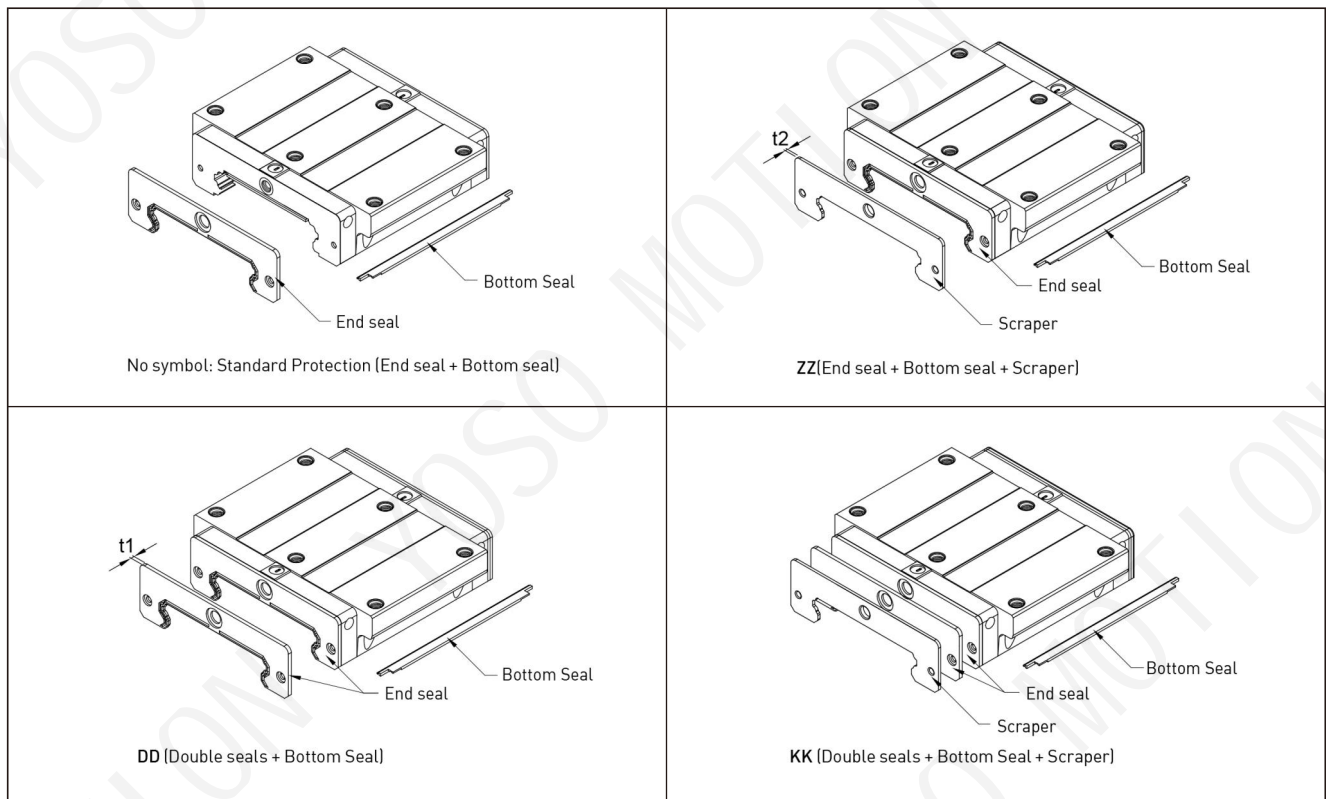

YOSO MOTION LINEAR GUIDE RAIL

YEH Series Four-Row Wide Rail

(2) End seal and bottom seal

Protects against contaminants entering the block. Reduces potential for groove damage resulting in a reduction of life ratings.

(3) Double seals

Removes foreign matter from the rail preventing contaminants from entering the block.

Table 2-3-11 Dimensions of Scraper

Size	Thickness (t1) (mm)	Size	Thickness (t2) (mm)
YEH15ES	1.6	YEH35ES	2
YEH21ES	2	YEH50ES	2.5
YEH27ES	2		

(4) Scraper

Clears larger contaminants, such as weld spatter and metal cuttings, from the rail. Metal scraper protects end seals from excessive damage.

Table 2-3-14 Dimensions of Scraper

Size	Thickness (t2) (mm)	Size	Thickness (t2) (mm)
YEH17SC	1	YEH35SC	1.5
YEH21SC	1	YEH50SC	1
YEH27SC	1		

(5) Bolt caps for rail mounting holes

Rail mounting hole caps prevent foreign matter from accumulating in the mounting holes. Caps are included with the rail package.

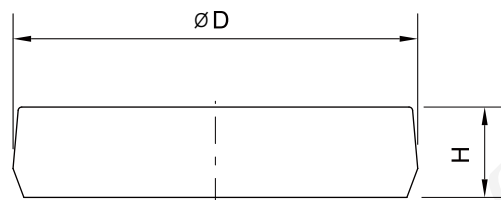

Table 2-3-13 Dimensions of Bolt Caps for Rail Mounting Holes

Rail size	Bolt size	Diameter(D) (mm)	Thickness(H) (mm)
YER17R	M4	7.65	1.1
YER21R	M4	7.65	1.1
YER27R	M4	7.65	1.1
YER35R	M6	11.15	2.5
YER50R	M8	14.20	3.5

YEH Series Four-Row Wide Rail

(6) Dimensions of block equipped with the dustproof parts

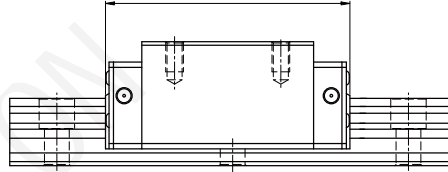

Table 2-3-14 Overall block length

Unit:mm

Size	Overall block length(L)			
	SS	ZZ	DD	KK
YEH17C	50.6(51.5)	52.6(55.6)	53.8(55.0)	55.8(58.8)
YEH21C	59.0(63.0)	61.0(67.0)	63.0(67.0)	65.0(71.0)
YEH27C	72.8(77.2)	74.8(80.8)	76.8(81.2)	78.8(84.8)
YEH35C	102.6(106.6)	105.6(111.6)	106.6(110.6)	109.6(115.6)
YEH50C	140.0(141.6)	142.0(146.2)	145.0(146.6)	147.0(151.2)

Note : The marking of "()" denotes the maximum block length with screws, lips of end seals, etc.

2-3-9 Friction

The maximum value of resistance per end seal are as shown in the table.

Table 2-3-15 Seal Resistance

Size	Resistance N(kgf)	Size	Resistance N(kgf)
YEH17	1.18(0.12)	YE35	3.92(0.4)
YEH21	1.96(0.2)	YE50	3.92(0.4)
YEH27	2.94(0.3)		

Note: 1. 1kgf=9.81N

2-3-10 Mounting Surface Accuracy Tolerance

Because of the circular-arc contact design, the YE linear guideway can withstand surface-error installation and deliver smooth linear motion. When the mounting surface meets the accuracy requirements of the installation, the high accuracy and rigidity of the guideway will be obtained without any difficulty. For faster installation and smoother movement, YOSO offers a preload with normal clearance because of its ability to absorb higher deviations in mounting surface inaccuracies.

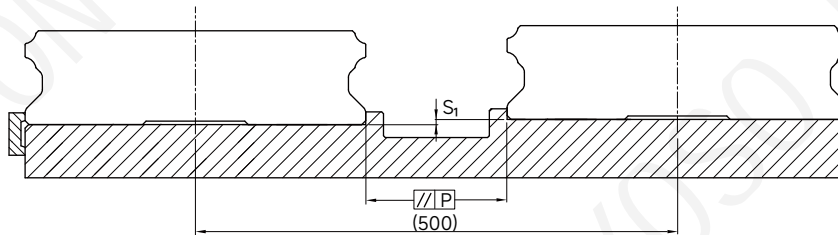

Table 2-3-16 Max, Parallelism Tolerance (P)

Unit:μm

Size	Preload classes			Size	Preload classes		
	Z0	ZA	ZB		Z0	ZA	ZB
YEH17	20	15	9	YE35	30	22	20
YEH21	25	18	9	YE50	40	30	27
YEH27	25	20	13				

YOSO MOTION LINEAR GUIDE RAIL

YEH Series Four-Row Wide Rail

Table 2-3-17 Max. Tolerance of Reference Surface Height (S)

Unit: μm

Size	Preload classes			Size	Preload classes		
	Z0	ZA	ZB		Z0	ZA	ZB
YEH17	65	20	-	YE35	130	85	70
YEH21	130	85	45	YE50	170	110	90
YEH27	130	85	45				

Note : Permissible value is proportional to the axial distance.

2-3-11 Cautions for Installation

(1) Shoulder heights and chamfers

Improper shoulder heights and fillets of mounting surfaces will cause a deviation in accuracy and the interference with the rail or block. As long as the recommended shoulder heights and fillets are followed, installation inaccuracies should be eliminated.

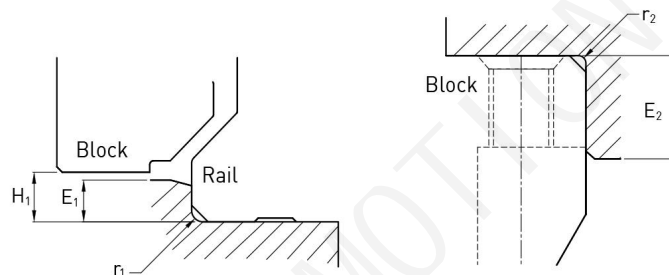

Table 2-3-18 Shoulder Heights and Chamfers

Size	Max.radius of fillets	Max.radius of fillets	Shoulder height beside the rail	Shoulder height beside the block	Clearance under block
	r_1 (mm)	r_2 (mm)	E_1 (mm)	E_2 (mm)	H_1 (mm)
YEH17	0.4	0.4	2.0	4.0	2.5
YEH21	0.4	0.4	2.5	5.0	3.0
YEH27	0.5	0.4	3.0	7.0	4.0
YEH35	0.5	0.5	3.5	10.0	4.0
YEH50	0.8	0.8	6.0	10.0	7.5

(2) Tightening Torque of Bolts for Installation

Improperly tightened mounting bolts will seriously affect the accuracy of linear guide installations. The following tightening torques for different sizes of bolts are recommended.

Table 2-3-19 Tightening Torque

Size	Bolt size	Torque N-cm(kgf-cm)		
		Iron	Casting	Aluminum
YEH17	M4×0.7P×12L	392(40)	274(28)	206(21)
YEH21	M4×0.7P×12L	392(40)	274(28)	206(21)
YEH27	M4×0.7P×16L	392(40)	274(28)	206(21)
YEH35	M6×1P×20L	1373(140)	921(94)	686(70)
YEH50	M8×1.25P×25L	3041(310)	2010(205)	1470(150)

Note: 1 kgf= 9.81 N

YEH Series Four-Row Wide Rail

2-3-12 Standard and Maximum Lengths of Rail

YOSO offers a number of standard rail lengths. Standard rail lengths feature end mounting hole placements set to predetermined values (E). For non-standard rail lengths, be sure to specify the E-value to be no greater than 1/2 the pitch (P) dimension. An E-value greater than this will result in unstable rail ends.

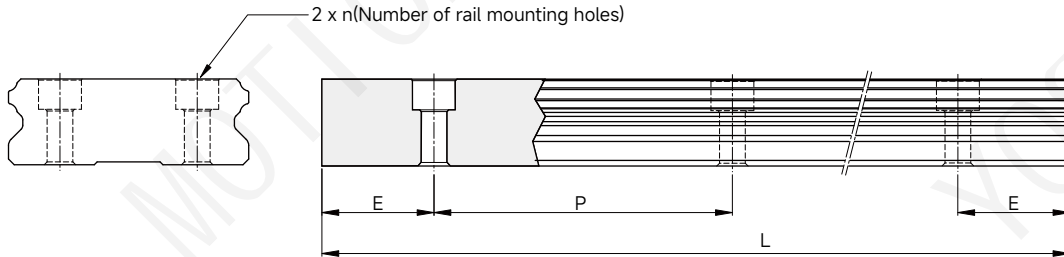

$$L = (n - 1) \times P + 2 \times E \quad \dots \dots \dots \text{Eq.2.3}$$

- L : Total length of rail (mm)
- n : Number of mounting holes
- P : Distance between any two holes (mm)
- E : Distance from the center of the last hole to the edge (mm)

Table 2-3-20 Rail Standard Length and Max. Length

Item	YER17	YER21	YER27	YER35	YER50
Standard Length L(n)	110(3)	130(3)	220(4)	280(4)	280(4)
	190(5)	230(5)	280(5)	440(6)	440(6)
	310(8)	380(8)	340(6)	600(8)	600(8)
	390(10)	480(10)	460(8)	760(10)	760(10)
	470(12)	580(12)	640(11)	1,000(13)	1,000(13)
	550(14)	780(16)	820(14)	1,640(21)	1,640(21)
	-	-	1,000(17)	2,040(26)	2,040(26)
	-	-	1,240(21)	2,520 (32)	2,520(32)
Pitch(P)	40	50	60	80	80
Distance to End(Es)	15	15	20	20	20
Max.Standard Length	3,990(100)	3,980(80)	4,000(67)	3,960(50)	3,960(50)
Max.Length	4,000	4,000	4,000	4,000	4,000

Note : 1. Tolerance of E value for standard rail is 0.5--0.5 mm. Tolerance of E value for jointed rail is 0--0.3 mm.
 2. Maximum standard length means the max. rail length with standard E value on both sides.
 3. If different E value is needed, please contact YOSO

YOSO MOTION LINEAR GUIDE RAIL

YEH Series Four-Row Wide Rail

2-3-13 Dimensions for YOSO YEH Series

(1) YEH-R

YEH17R
YEH21R

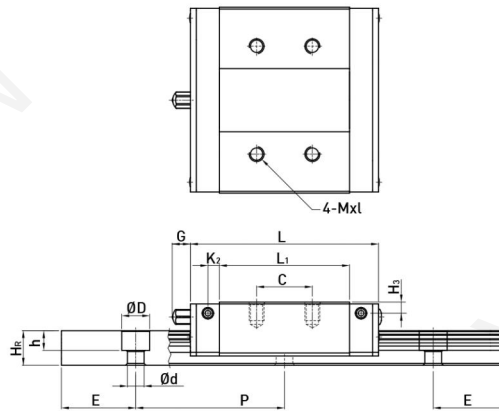
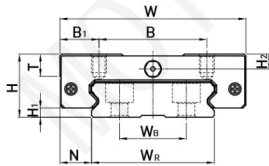

YEH27R
YEH35R
YEH50R

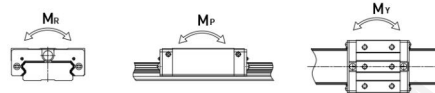
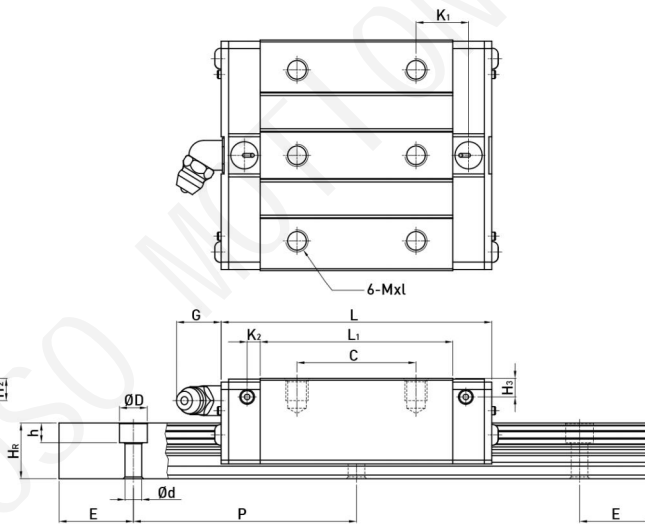
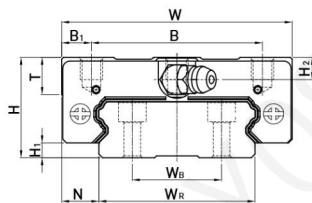

Model No.	Dimensions of Assembly (mm)		Dimensions of Block (mm)											Dimensions of Rail (mm)							Mounting Bolt for Rail (mm)	Basic Dynamic Load Rating C (kN)	Basic Static Load Rating Cs (kN)	Static Rated Moment			Weight					
	H	H1	N	W	B	B1	C	L1	L	K1	K2	G	Mxl	T	H2	H3	Wn	Wn	Hn	D				h	d	P	E	Mr (kN-m)	Mp (kN-m)	Mv (kN-m)	Block (kg)	Rail (kg/m)
YEH17R	17	2.5	8.5	50	29	10.5	15	35	50.6	-	3.1	4.9	M4×5	6	4	3	33	18	9.3	7.5	5.3	4.5	40	15	M4×12	5.23	9.64	0.15	0.062	0.062	0.12	2.2
YEH21R	21	3	8.5	54	31	11.5	19	41.7	59	14.68	3.65	12	M5×6	8	4.5	4.2	37	22	11	7.5	5.3	4.5	50	15	M4×12	7.21	13.7	0.23	0.10	0.10	0.20	3.0
YEH27R	27	4	10	62	46	8	32	51.8	72.8	14.15	3.5	12	M6×6	10	6	5	42	24	15	7.5	5.3	4.5	60	20	M4×16	12.4	21.6	0.42	0.17	0.17	0.35	4.7
YEH35R	35	4	15.5	100	76	12	50	77.6	102.6	18.35	5.25	12	M8×8	13	8	6.5	69	40	19	11	9	7	80	20	M6×20	29.8	49.4	1.48	0.67	0.67	1.1	9.7
YEH50R	50	7.5	20	130	100	15	65	112	140	28.05	6	12.9	M10×15	19.5	12	10.5	90	60	24	14	12	9	80	20	M8×25	61.52	97.1	4.03	1.96	1.96	3.16	15.5

Note :1 kgf= 9.81 N

YEH Series Four-Row Wide Rail

(2) YEH-C

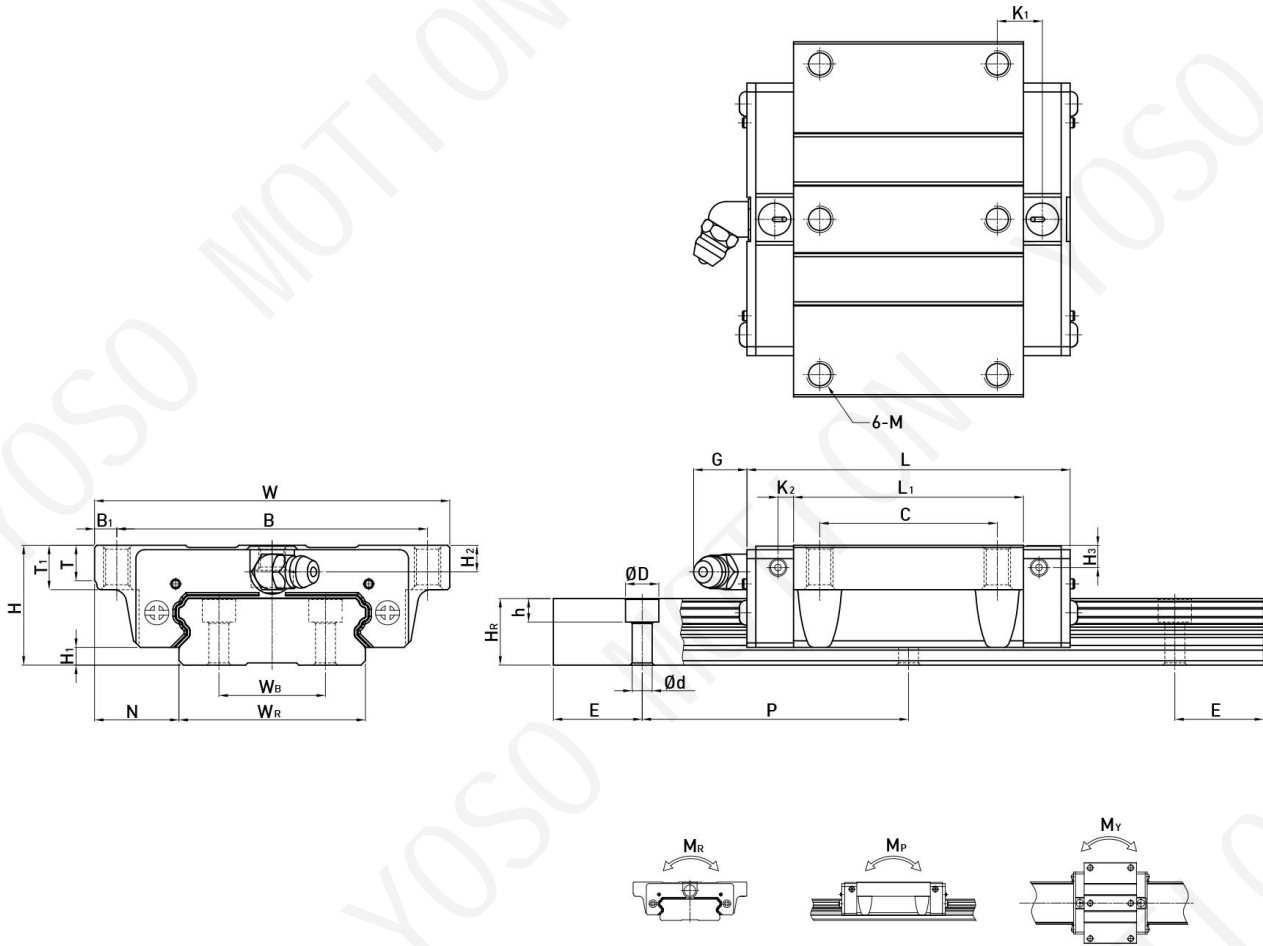

Model No.	Dimensions of Assembly (mm)		Dimensions of Block(mm)													Dimensions of Rail (mm)							Mounting Bolt for Rail (mm)	Basic Dynamic Load Rating C(kN)	Basic Static Load Rating Co(kN)	Static Rated Moment			Weight				
	H	H ₁	N	W	B	B ₁	C	L ₁	L	K ₁	K ₂	G	M	T	T ₁	H ₂	H ₃	W _s	W _r	H ₂	D	h				d	P	E	M _R (kN-m)	M _P (kN-m)	M _Y (kN-m)	Block (kg)	Rail (kg/m)
YEH17C	17	2.5	13.5	60	53	3.5	26	35	50.6	-	3.1	4.9	M4	5.3	6	4	3	33	18	9.3	7.5	5.3	4.5	40	15	M4×12	5.23	9.64	0.15	0.062	0.062	0.13	2.2
YEH21C	21	3	15.5	68	60	4	29	41.7	59	9.68	3.65	12	M5	7.3	8	4.5	4.2	37	22	11	7.5	5.3	4.5	50	15	M4×12	7.21	13.7	0.23	0.10	0.10	0.23	3.0
YEH27C	27	4	19	80	70	5	40	51.8	72.8	10.15	3.5	12	M6	8	10	6	5	42	24	15	7.5	5.3	4.5	60	20	M4×16	12.4	21.6	0.42	0.17	0.17	0.43	4.7
YEH35C	35	4	25.5	120	107	6.5	60	77.6	102.6	13.35	5.25	12	M8	11.2	14	8	6.5	69	40	19	11	9	7	80	20	M6×20	29.8	49.4	1.48	0.67	0.67	1.26	9.7
YEH50C	50	7.5	36	162	144	9	80	112	140	20.55	6	12.9	M10	14	18	12	10.5	90	60	24	14	12	9	80	20	M8×25	61.52	97.1	4.03	1.96	1.96	3.71	15.5

Note :1 kgf= 9.81 N

YSS Series Miniature Type

■ YSS Series-Miniature Linear Guideway

2-4-1 Features of YSS Series

Design features of narrow type miniature guideways- YSS:

1. Tiny and light weight, suitable for miniature equipment.
2. Gothic arch contact design can sustain loads from all directions and offer high rigidity and high accuracy.
3. Specification with ball retainers would avoid ball falling when the blocks are removed from rails.
4. Interchangeable types are available in certain sizes and precision grades.

2-4-2 Construction of MGN Series

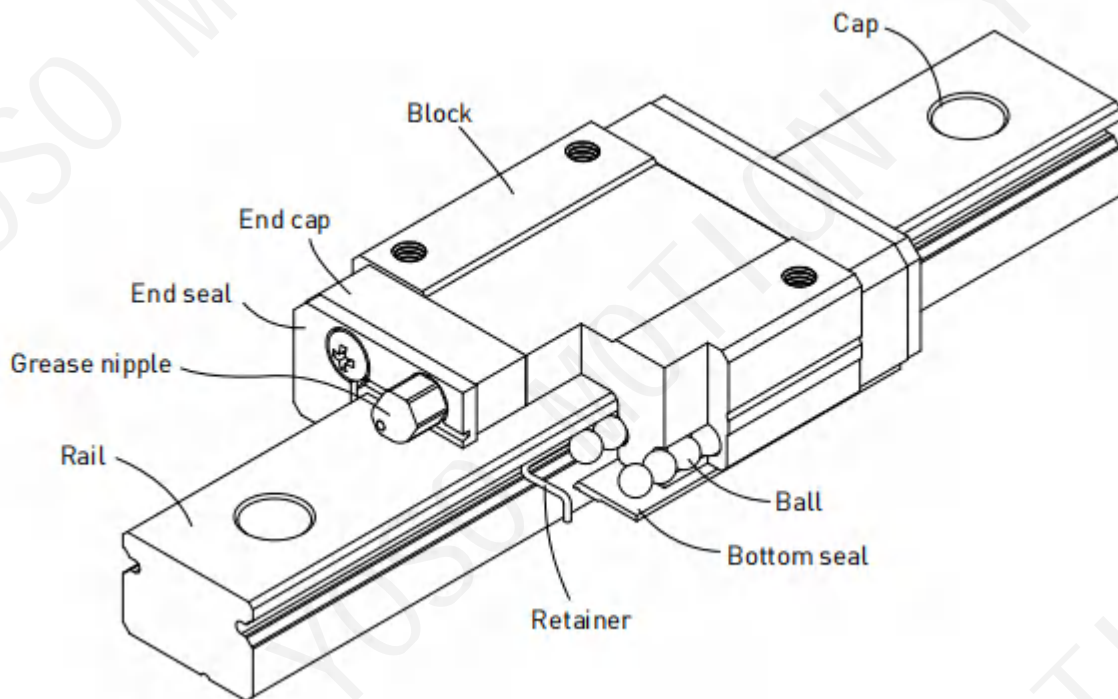

- Rolling circulation system: Block, rail, ball, end cap and retainer (except size 2, 3)
- Lubrication system: Grease nipple is available for YSS15, lubricated by grease gun. YSS7,9, 12 are lubricated by the hole at the side of the end cap.
- Dust protection system: End seal, bottom seal, cap and scraper

YSS Series Miniature Type

2-4-3 Features of YSS Series

Design features of wide type miniature guideways- YSS:

1. The enlarged width design increases the capacity of moment loading.
2. Gothic arch contact design has high rigidity characteristic in all directions.
3. Specification with ball retainers would avoid ball falling when the blocks are removed from rails.
4. Interchangeable types are available in certain sizes and precision grades.

2-4-4 Construction of YSS Series

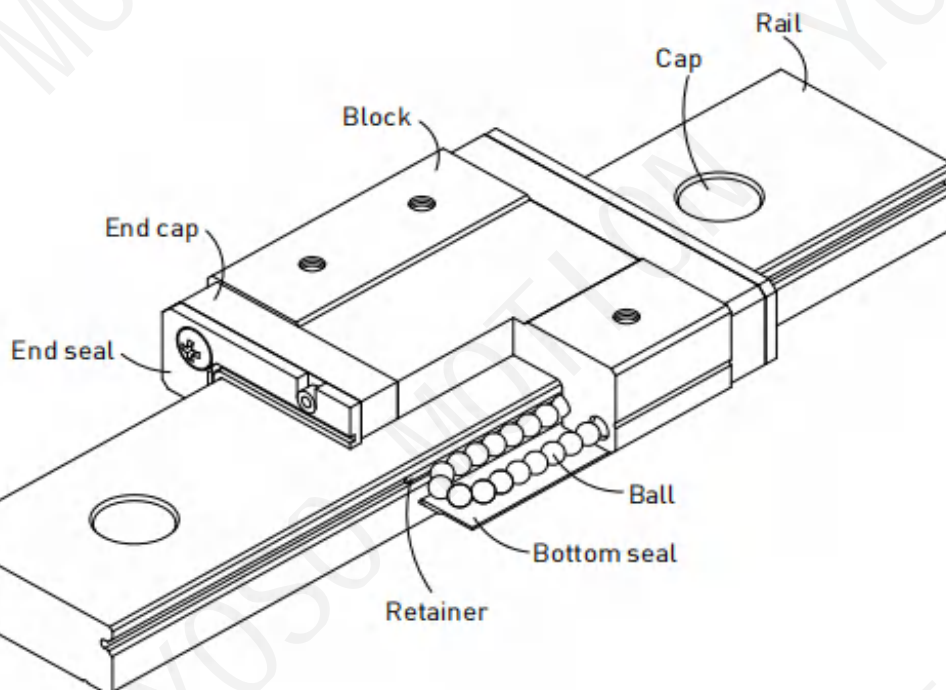

- Rolling circulation system: Block, rail, ball, end cap and retainer (except size 2)
- Lubrication system: Grease nipple is available for YSS14, 15, lubricated by grease gun.
- YSS3, 7, 9, 12 are lubricated by the hole at the side of the end cap.
- Dust protection system: End seal (except size 2), bottom seal optional size 9,12,14,15, cap (size 12,14,15)

YOSO MOTION LINEAR GUIDE RAIL

YSS Series Miniature Type

2-4-5 Features of MGN-0 Series

Design features of narrow type miniature guideways-YSS-0:

1. Reduce 20% weight of block by using resin in the recirculation unit. The compact size and light weight is suitable for miniaturized machinery.
2. Gothic arch contact design can sustain loads from all directions and offer high rigidity and high accuracy.
3. Interchangeable types are available in certain precision grades.
4. The design of resin recirculation unit which is able to eliminate the collision with the metal block.
5. Integrated design for recirculation system.

2-4-6 Construction of YSS-0 Series

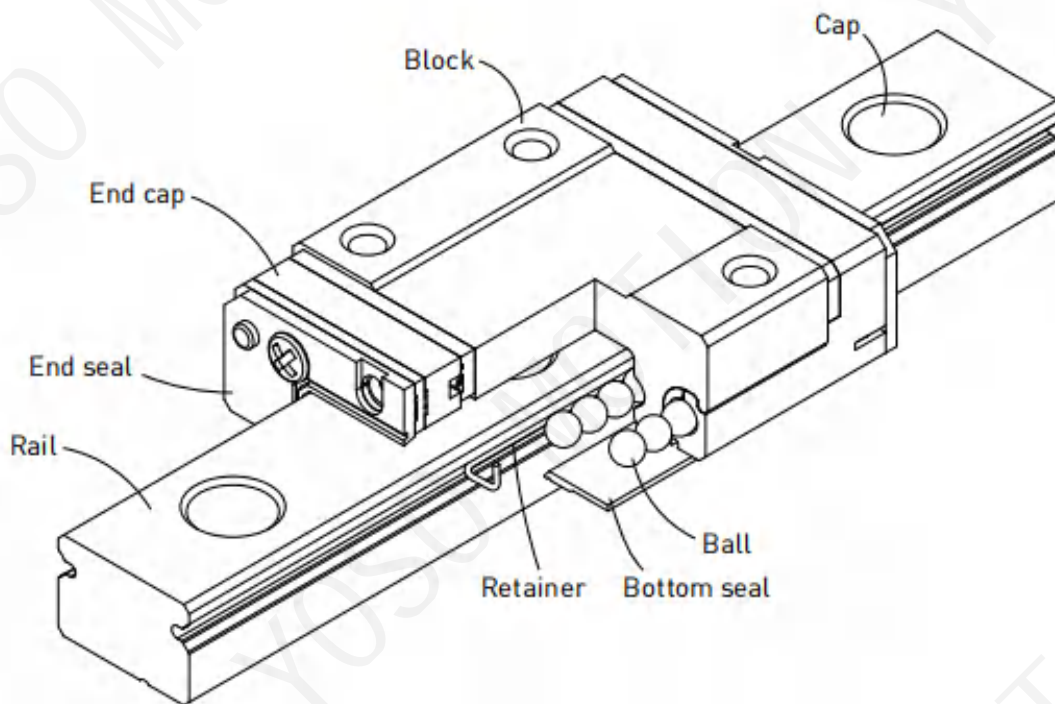

- Rolling circulation system: Block, rail, ball, end cap and retainer
- Lubrication system: Grease nipple is available for YSS15-0, lubricated by grease gun.
- YSS5-0, YSS7-0, YSS9-0, YSS12-0 are lubricated by the hole at the side of the end cap Dust
- protection system: End seal, bottom seal optional (size 9, 12, 15), cap (size 12, 15)

YSS Series Miniature Type

2-4-7 Features of YSS-0 Series

Design features of wide type miniature guideways-MGW-0:

1. The enlarged width design increases the capacity of moment loading.
2. Gothic arch contact design has high rigidity characteristic in all directions.
3. Steel balls are held by a miniature retainer to keep balls from falling out, even when the blocks are removed from the rail.
4. Integrated design for recirculation system, which reduce 20% weight of block by using resin in the recirculation unit.

2-4-8 Construction of YSS-0 Series

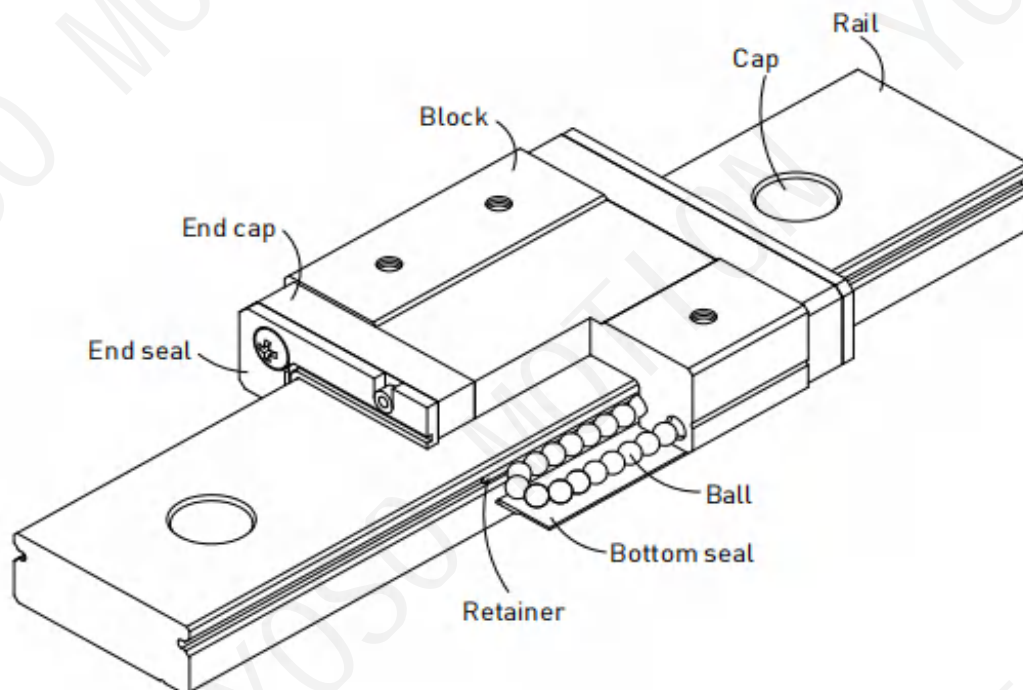

- Rolling circulation system: Block, rail, ball, end cap and retainer
- Lubrication system: Grease nipple is available for YSS15-0, lubricated by grease gun. YSS5-0, YSS7-0, YSS9-0, YSS12-0 are lubricated by the hole at the side of the end cap.
- Dust protection system: End seal, bottom seal (optional) (size 9, 12, 15), cap (size 12, 15)

2-4-9 Application

YSS series can be used in various applications, such as semiconductor equipment, PCB AC equipment, medical, robotics, measuring equipment, automation equipment, and other miniature sliding machinery.

YOSO MOTION LINEAR GUIDE RAIL

YSS Series Miniature Type

2-4-10 Model Number of YSS Series

YSS Series linear guideway can be classified into non-interchangeable and interchangeable types, which are the same size. The interchangeable type is more convenient due to replaceable rails; however, the precision is less than non-interchangeable type. With strict dimension and quality control, the interchangeable type linear guideways are a suitable choice for customers when rails don't need to be paired. The model number contains information for the size, type, accuracy, preload, and so on.

(1) Non-interchangeable type

Perform joint treatment when required lengths exceed 1300. Please contact TB! MOTON for detailed information.

Y S 05 M N A - 2 - - 1000 - N A - Z0 - II - E

① ② ③ ④ ⑤ ⑥ ⑦ ⑧ ⑨ ⑩ ⑪ ⑫ ⑬ ⑭

①	②	③	④
Nominal Model	Block Type	Dimension	Width of Rail
YS	S : Mini E : Special	03,05,07,09,12,15	M : Standard W : Wide

⑤	⑥	⑦
Length of Block	Material of Block	Quantity of Block
S: Standard N: Long	S : Stainless steel A : Alloy steel	(Mark 1 when there is only 1 runner block)

⑧	⑨	⑩	⑪
Accessory Code	Length of Rail	Accuracy Grade	Material of Rail
<input type="checkbox"/> : Standard (Please refer to page A26)	Unit:mm	N: Normal H: High P: Precision	S : Stainless steel A : High Carbon steel

⑫	⑬	⑭
Preload	Two Sets per Axis	Rail Special Machining
ZF: Slight Clearance Z0: No Preload Z1: Light Preload	(No need to be marked when there is only one rail)	K : Tapped-Hole Rail E : Rail with Special Machining

No symbol required when plating is not needed

YSS Series Miniature Type

2-4-11 Types

(1) Block types

YOSO offers two types of linear guideways, flange and square types.

Table 2-4-1 Block Types

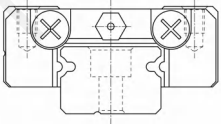
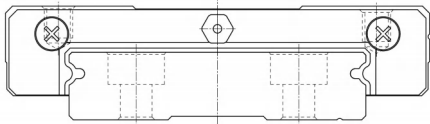
Type	Model	Shape	Height (mm)	Rail Length (mm)	Main Applications
Square	YSS-MS YSS-MN		3.2	30	<ul style="list-style-type: none"> ● Printer ● Robotics ● Precision measure equipment ● Semiconductor equipment
			16	2000	
Flange	YSS-WS YSS-WN		4	40	
			16	2000	

(2) Rail types

YOSO offers standard top mounting and bottom mounting type.

Table 2-4-2 Rail Types

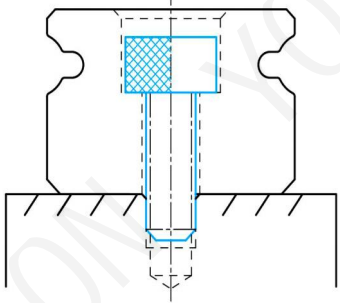
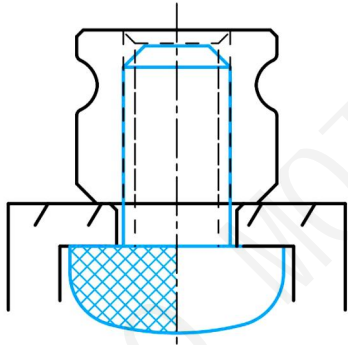
Mounting from Top	Mounting from bottom (MGN2, MGN3)
	

YOSO MOTION LINEAR GUIDE RAIL

YSS Series Miniature Type

2-4-12 Accuracy Classes

The accuracy of YSS series can be classified into three classes: normal (C), high (H), precision (P). Choices for different accuracy classes are available according to various requirements.

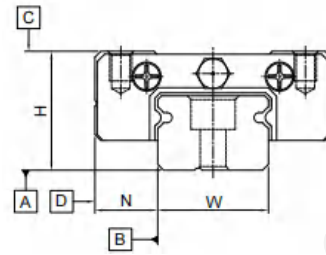

(1) Accuracy of non-interchangeable guideways

Table 2-4-3 Accuracy Standard of Non-interchangeable Type

Accuracy Classes	Normal (C)	High (H)	Precision (P)
Dimensional tolerance of height H	±0.04	±0.02	±0.01
Dimensional tolerance of width N	±0.04	±0.025	±0.015
Pair Variation of height H	0.03	0.015	0.007
Pair Variation of width N (Master Rail)	0.03	0.02	0.01
Running parallelism of block surface C to surface A	See Table 2-4-5		
Running parallelism of block surface D to surface B	See Table 2-4-5		

(2) Accuracy of interchangeable guideways

Table 2-4-4 Accuracy Standard of interchangeable Type

Accuracy Classes	Normal (C)	High (H)	Precision (P)
Dimensional tolerance of height H	±0.04	±0.02	±0.01
Dimensional tolerance of width N	±0.04	±0.025	±0.015
One Set	Pair Variation of height H	0.03	0.015
	Pair Variation of width N	0.03	0.02
Pair Variation of width N (Master Rail)	0.07	0.04	0.02
Running parallelism of block surface C to surface A	See Table 2-4-5		
Running parallelism of block surface D to surface B	See Table 2-4-5		

(2) Accuracy of interchangeable guideways

The running parallelism C to A and D to B are related to the rail length.

Table 2-4-4 Accuracy Standard of interchangeable Type

Rail Length (mm)	Accuracy (μm)			Rail Length (mm)	Accuracy (μm)		
	(C)	(H)	(P)		(C)	(H)	(P)
~50	12	6	2	1,000~1,200	25	18	11
50~80	13	7	3	1,200~1,300	25	18	11
80~125	14	8	3.5	1,300~1,400	26	19	12
125~200	15	9	4	1,400~1,500	27	19	12
200~250	16	10	5	1,500~1,600	28	20	13
250~315	17	11	5	1,600~1,700	29	20	14
315~400	18	11	6	1,700~1,800	30	21	14
400~500	19	12	6	1,800~1,900	30	21	15
500~630	20	13	7	1,900~2,000	31	22	15
630~800	22	14	8	2,000~	31	22	16
800~1,000	23	16	9				

YSS Series Miniature Type

2-4-13 Preload

YSS series provides three different preload levels for various applications.

Table 2-4-1 Block Types

Class	Code	Preload	Accuracy
Light Clearance	ZF	Clearance 4-10 μ m	C
Very Light Preload	Z0	Clearance 0-3 μ m	C~P
Light Preload	Z1	0.02C	C~P

Note: "C" in column preload means basic dynamic load rating.

● Stiffness performance

Stiffness depends on preload. The following table shows stiffness value of each size.

Table 2-4-7 Radial stiffness for YSS Series

Load type	Series/Size	Stiffness (N/ μ m)		Series/Size	Stiffness(N/ μ m)	
		Z0	Z1		Z0	Z1
Standard	YSS5MS-0	20	61	YSS5WS-0	32	85
	YSS7MS	26	73	YSS7WS	44	112
	YSS9MS	38	102	YSS9WS	62	140
	YSS12MS	44	105	YSS12WS	72	148
	YSS15MS	58	126	YSS15WS	85	154
Long	YSS5MN-0	26	79	YSS5WN-0	-	-
	YSS7MN	42	122	YSS7WN	64	168
	YSS9MN	56	153	YSS9WN	81	190
	YSS12MN	70	175	YSS12WN	102	217
	YSS15MN	89	202	YSS15WN	122	235

2-4-14 Dust Proof Accessories

End seals on both sides of the block can prevent dust from entering the block and maintain the accuracy and servicelife of a linear guideway. End seals for YSS3MS are optional, customers can order it by adding the mark "+SS" followed by the model number. For other size of YSS series, end seals are standard accessories. Bottom seals are fixed under the skirt portion of the block to prevent dust from entering. Customers can order bottom seals by adding the mark "+U" followed by the model number. Sizes 9, 12, 14 and 15 provide bottom seals as an option, but size 2, 3, 5, 7 do not offer the option due to the space limit of H₁. Note that "H₁" would be reduced if bottom seals are attached, be aware of possible interference between block and mounting surface.

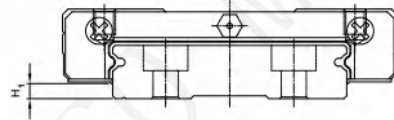

Table 2-4-8

Size	Bottom seal	H ₁ mm	Size	Bottom seal	H ₁ mm
YSS2	-	-	YSS2	-	-
YSS3	-	-	YSS3	-	-
YSS7	-	-	YSS7	-	-
YSS9	●	1	YSS9	●	1.9
YSS12	●	2	YSS12	●	2.4
-	-	-	YSS14	●	2.4
YSS15	●	3	YSS15	●	2.4
YSS5-0	-	-	YSS5-0	-	-
YSS7-0	-	-	YSS7-0	-	-
YSS9-0	●	1.2	YSS9-0	●	1.95
YSS12-0	●	2	YSS12-0	●	2.45
YSS15-0	●	3	YSS15-0	●	2.45

YOSO MOTION LINEAR GUIDE RAIL

YSS Series Miniature Type

- Bolt caps for rail mounting holes

Rail mounting hole caps prevent foreign matter from accumulating in the mounting holes. Caps are included with the rail package.

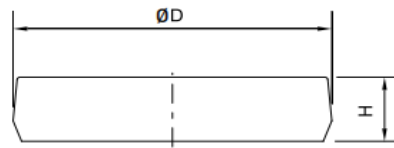

Table 2-4-9 Dimensions of Bolt caps for Rail Mounting Holes

Rail size	Bolt size	Diameter(D) (mm)	Thickness(H) (mm)
YSS12	M3	6.15	1.2
YSS15	M3	6.15	1.2
YSS12	M4	8.15	2.2
YSS14	M4	8.15	2.2
YSS15	M4	8.15	2.2

2-4-15 Mounting Surface Accuracy Tolerance

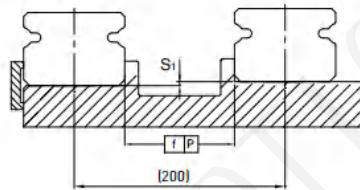

Table 2-4-10 Max. Parallelism Tolerance (P)

Size	Preload classes			Size	Preload classes		
	ZF	Z0	Z1		ZF	Z0	Z1
YSS2	2	2	2	YSS9	4	4	3
YSS3	2	2	2	YSS12	9	9	5
YSS5	2	2	2	YSS14	10	10	6
YSS7	3	3	3	YSS15	10	10	6

Table 2-4-11 Max. Tolerance of Reference Surface Height (S1)

Size	Preload classes			Size	Preload classes		
	ZF	Z0	Z1		ZF	Z0	Z1
YSS2	15	15	2	YSS9	35	35	6
YSS3	15	15	2	YSS12	50	50	12
YSS5	20	20	2	YSS14	60	60	20
YSS7	25	25	3	YSS15	60	60	20

Table 2-4-12 Permissible Error of Mounting Surface

Size	Flatness of the Mounting Surface	Size	Flatness of the Mounting Surface
YSS2	0.012/200	YSS9	0.035/200
YSS3	0.012/200	YSS12	0.050/200
YSS5	0.015/200	YSS14	0.060/200
YSS7	0.025/200	YSS15	0.060/200

Note: The values above are suitable for preload of ZF/Z0. For preload of Z1 or using two or more rail on the same plane, 50% or less of the values above are recommended.

YSS Series Miniature Type

2-4-16 Cautions for Installation

(1) Shoulder heights and fillets

Improper shoulder heights and fillets of mounting surfaces will cause a deviation in accuracy and the interference with the rail or block. As long as the recommended shoulder heights and fillets are followed, installation inaccuracies should be eliminated.

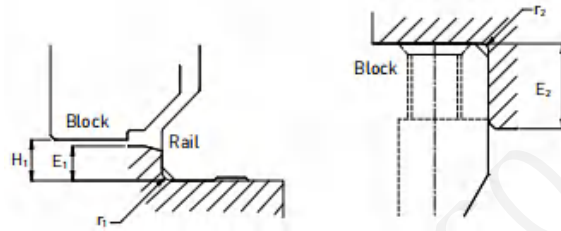

Table 2-4-13 Shoulder Heights and Fillets

Size	Max.radius of fillets r ₁ (mm)	Max.radius of fillets r ₂ (mm)	Shoulder height beside the rail E ₁ (mm)	Shoulder height beside the rail E ₂ (mm)	Clearance under block H ₁ (mm)
YSS2	0.1	0.2	0.5	1.5	0.7
YSS3	0.1	0.2	0.6	1.5	1
YSS5	0.1	0.2	1.2	2	1.5
YSS7	0.2	0.2	1.2	3	1.5
YSS9	0.2	0.3	1.7	3	2
YSS12	0.3	0.4	1.7	4	3
YSS15	0.5	0.5	2.5	5	4
YSS2	0.1	0.2	0.6	1.5	1
YSS3	0.1	0.2	0.6	2	1
YSS5	0.1	0.2	1.2	2	1.5
YSS7	0.2	0.2	1.7	3	1.9
YSS9	0.3	0.3	2.5	3	2.9
YSS12	0.4	0.4	3	4	3.4
YSS14	0.4	0.4	3	5	3.5
YSS15	0.4	0.8	3	5	3.4

(2) Tightening torque of bolts for installation

Improper tightening of rail mounting bolts will seriously affect the accuracy of the linear guideway. The following table lists the recommended tightening torque for the specific bolt sizes.

Table 2-4-14 Tightening Torque

Size	Bolt size	Torque, N-cm (kgf-cm)		
		Iron	Casting	Aluminum
YSS5	M2×0.4P×6L	57(5.9)	39.2(4)	29.4(3)
YSS7	M2×0.4P×6L	57(5.9)	39.2(4)	29.4(3)
YSS9	M3×0.5P×8L	186(19)	127(13)	98(10)
YSS12	M3×0.5P×8L	186(19)	127(13)	98(10)
YSS15	M3×0.5P×10L	186(19)	127(13)	98(10)
YSS2	M1.6×0.35P×4.4L	27.6(2.8)	19(1.94)	14.2(1.45)
YSS3	M2×0.4P×6L	57(5.9)	39.2(4)	29.4(3)
YSS5	M2.5×0.45P×7L	118(12)	78.4(8)	58.8(6)
YSS7	M3×0.5P×6L	186(19)	127(13)	98(10)
YSS9	M3×0.5P×8L	186(19)	127(13)	98(10)
YSS12	M4×0.7P×8L	392(40)	274(28)	206(21)
YSS14	M4×0.7P×10L	392(40)	274(28)	206(21)
YSS15	M4×0.7P×10L	392(40)	274(28)	206(21)

Note : 1 kgf=9.81N

YOSO MOTION LINEAR GUIDE RAIL

YSS Series Miniature Type

2-4-17 Standard and Maximum Lengths of Rail

YOSO offers standard lengths of rail for fast shipping. For non-standard rail lengths, it's recommended that the E value is no greater than 1/2 of the pitch (P) to prevent instability at the end of the rail, and the E value should be no less than E-min to avoid a broken mounting hole.

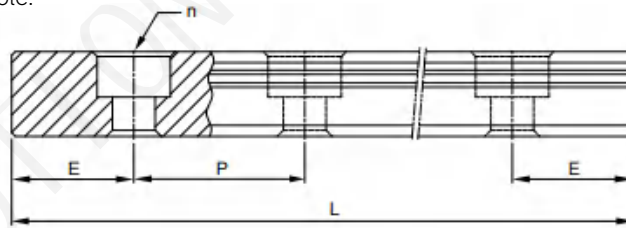

$$L = (n - 1) \times P + 2 \times E \quad \text{Eq.2.4}$$

- L : Total length of rail (mm)
- n : Number of mounting holes
- P : Distance between any two holes (mm)
- E : Distance from the center of the last hole to the edge (mm)

Table 2-4-15

Item	YSSM2	YSSM3	YSSM5	YSSM7	YSSM9	YSSM12	YSSM15	YSSW2	YSSW3	YSSW5	YSSW7	YSSW9	YSSW12	YSSW14	YSSW15
Standard Length L(n)	32(4)	30(3)	40(3)	40(3)	55(3)	70(3)	70(2)	40(4)	40(3)	50(3)	50(2)	80(3)	110(3)	110(3)	110(3)
	40(5)	40(4)	55(4)	55(4)	75(4)	95(4)	110(3)	60(6)	55(4)	70(4)	80(3)	110(4)	150(4)	150(4)	150(4)
	56(7)	50(5)	70(5)	70(5)	95(5)	120(5)	150(4)	70(7)	70(5)	90(5)	100(4)	140(5)	190(5)	190(5)	190(5)
	80(10)	60(6)	100(7)	85(6)	115(6)	145(6)	190(5)	80(8)	100(7)	100(6)	140(5)	170(6)	230(6)	230(6)	230(6)
	104(13)	80(8)	130(9)	100(7)	135(7)	170(7)	230(6)	100(10)	130(9)	130(7)	170(6)	200(7)	270(7)	270(7)	270(7)
		100(10)	160(10)	130(9)	155(8)	195(8)	270(7)		160(11)	150(8)	200(7)	230(8)	310(8)	310(8)	310(8)
					175(9)	220(9)	310(8)			170(9)	260(9)	260(9)	350(9)	350(9)	350(9)
					195(10)	245(10)	350(9)				290(10)	290(10)	390(10)	390(10)	390(10)
					275(14)	270(11)	390(10)					350(14)	430(11)	430(11)	430(11)
					375(19)	320(13)	430(11)					500(19)	510(13)	510(13)	510(13)
						370(15)	470(12)					710(24)	590(15)	590(15)	590(15)
						470(19)	550(14)					860(29)	750(19)	750(19)	750(19)
					570(23)	670(17)						910(23)	910(23)	910(23)	
					695(28)	870(22)						1070(27)	1070(27)	1070(27)	
Pitch(P)	8	10	15	15	20	25	40	10	15	20	30	30	40	40	40
Distance to End(E)	4	5	5	5	7.5	10	15	5	5	5	10	10	15	15	15
Max. Standard Length	248(31)	250(25)	250(17)	595(40)	1195(60)	1995(80)	1990(50)	250(25)	250(17)	250(13)	590(20)	1970(66)	1990(50)	1790(45)	1990(50)
Max. Length	250 ⁶	250 ⁶	250 ⁶	600	1200 ⁷	2000	2000	250 ⁶	250 ⁶	250 ⁶	600 ⁸	2000	2000	1800 ⁵	2000

Note: 1. Tolerance of E value for standard rail is 0.5--0.5 mm. Tolerance of E value for jointed rail is 0--0.3 mm.

2. Maximum standard length indicates the max. rail length with standard E value on both sides.

3. Fixing screws for YSSM5s mounting holes are appended.

4. If smaller E value is needed, please contact YOSO.

5. YSSW14 is only supplied with carbon steel.

6. YSSM2, YSSM3, YSSW3, YSSM5, YSSW5 are only supplied with stainless steel.

7. YSSM9 of stainless steel is supplied with the maximum length of 1200mm; MGNR9 of carbon steel is supplied with the maximum length of 1000mm.

8. YSSW7 of stainless steel is supplied with the maximum length of 600mm; YSSW7 of carbon steel is supplied with the maximum length of 2000mm.

YSS Series Miniature Type

2-4-18 EL Auxiliary Lubrication Module

The EL Auxiliary Lubrication Module is an environment friendly lubrication system that can extend the maintenance life of YOSO and quideways up to 10,000 km. The module is installed on either end of a quideway block and provides extended lubrication through a no-drip encapsulated material for a cleaner environmental solution.

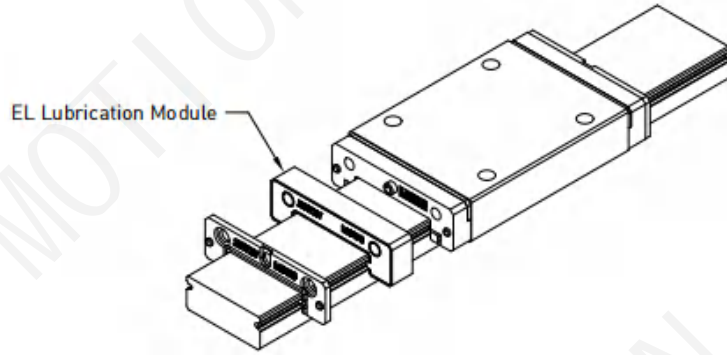

(1) Feature

1. Extend maintenance period up to 10,000km
2. Contained lubrication fluid prevents spills
3. Direct lubrication in ball rolling raceway,
4. Compatible with most YOSO guideways.
5. Conform to cleanroom class 1000 regulation.

Notes :

1. Service life will vary from application environment, lubrication conditions, and assembly accuracy.
2. Not for use in high heat conditions greater than 50°C ,and if lower than 25°C please contact YOSO.
3. Standard parts must be pregreased with YOSO G05. If there is no pregreasing, the maintenance mileage will be shortened.

(2) Applications

Broadly applicable in automation, conveying equipment, industrial machine, Semi-conductor, and inspection machine.

(3) Lubrication Capability

- High speed life testing with light load

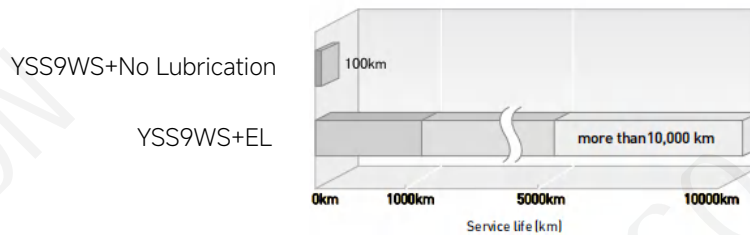

Test Specification	YSS9WS1R1000Z0CM+EL
Velocity	5m/s
Acceleration	50 m/s ²
Applied Load	0.2 kgf
Stroke	850 mm
Lubrication	Lithium Soap Grease+EL
Distance travel	10,000 km

YOSO MOTION LINEAR GUIDE RAIL

YSS Series Miniature Type

(4) Dimension Table for EL Type

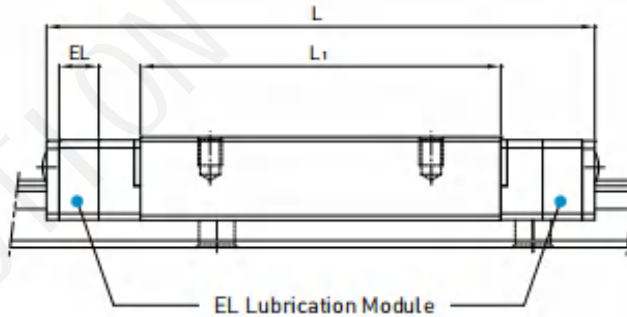

Model No.	Lubrication device (R _i)	Block length (L ₁)	Total length (L)
YSS7MS	3.5	13.5	29.5
YSS7MN		21.8	37.8
YSS9MS	5	18.9	38.9
YSS9MN		29.9	49.9
YSS12MS	5	21.7	44.7
YSS12MN		32.4	55.4
YSS9WS	5	27.5	49.3
YSS9WN		38.5	60.7
YSS12MS	5	31.3	56.1
YSS12WN		45.6	70.4

YSS Series Miniature Type

2-4-19 YSS-MS/YSS-MN Series Specifications

YSS3M、YSS5M、YSS7M、YSS9M、YSS12M

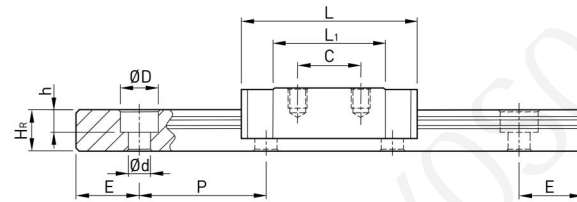
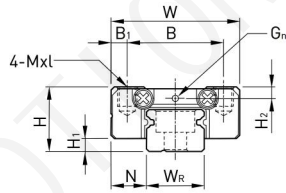

YSS15M

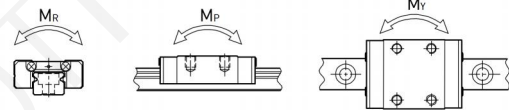
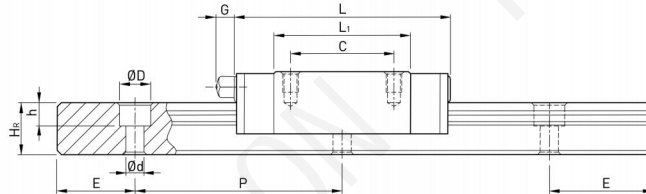
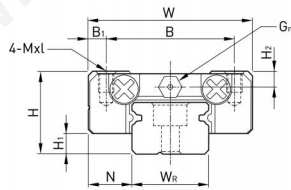

Model	Component size		Slider size(MM)										Slide rail size(MM)							Slide rail fixing bolt dimensions (mm)	Basic dynamic load rating C(kN)	Basic static load rating Co (kN)	Allowable static moment			weight		
	H	H1	N	W	B	B1	C	L1	L	G	G	Mxl	H2	W	H	D	h	d	P				E	M N-m	M N-m	My N-m	slider kg	guide kg/m
YSS 3MS	4	1	2.5	8	-	-	3.5	6.7	12	-	-	M1.6x1.3	-	3	2.6	-	-	1.6	10	5	M1.6x1	0.19	0.32	0.6	0.4	0.4	-	-
YSS 3MN							5.5	10.7	16			M2x1.3									M1.6x1	0.3	0.58	0.9	1.1	1.1	-	-
YSS 5MS	6	1	3.5	12	8	2	-	9.7	16	-	-	M2x2	-	5	3.7	3.6	0.8	2.4	15	7.5	M2x6	0.34	0.56	1.7	1	1	-	-
YSS 5MN							-	12.7	19												M2x6	0.48	0.92	2.4	2.1	2.1	-	-
YSS 7MS	8	1.5	5	17	12	2.5	8	13.5	22.5	-	φ1.2	M2x2.5	1.5	7	4.8	4.2	2.3	2.4	15	5	M2x6	0.98	1.24	4.70	2.84	2.84	0.010	0.22
YSS 7MN							13	21.8	30.8												M2x6	1.37	1.96	7.64	4.80	4.80	0.015	-
YSS 9MS	10	2	5.5	20	15	2.5	10	18.9	29.8	-	φ1.2	M3x3	1.8	9	6.5	6	3.5	3.5	20	7.5	M5x8	1.86	2.55	11.76	7.35	7.35	0.016	0.38
YSS 9MN							16	29.9	39.9												M5x8	2.55	4.02	19.60	18.62	18.62	0.026	-
YSS 12MS	15	3	7.5	27	20	3.5	15	21.7	34.7	-	φ1.4	M3x3.5	2.5	12	8	6	4.5	3.5	25	10	M5x8	2.84	3.92	25.47	13.81	13.81	0.034	0.65
YSS 12MN							20	32.4	45.4												M5x8	3.72	5.88	39.22	36.26	36.26	0.054	-
YSS 15MS	16	4	8.5	32	25	3.5	20	26.7	42.1	-	φ1.4	M3x4	3	15	10	6	4.5	3.5	40	15	M5x10	4.61	5.59	45.08	21.56	21.56	0.059	1.06
YSS 15MN							25	43.3	58.8												M5x10	6.37	9.11	73.50	57.82	57.82	0.092	-

Note: 1kgf=9.81N

YOSO MOTION LINEAR GUIDE RAIL

YSS Series Miniature Type

2-4-20 YSS-WS/YSS-WN Series Specifications

YSS3W、YSS5W、YSS7W、YSS9W、YSS12W

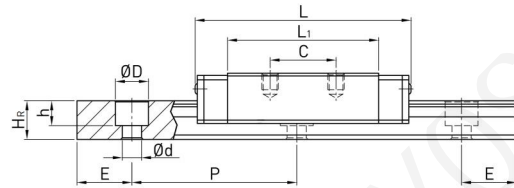
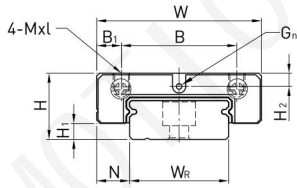

YSS15W

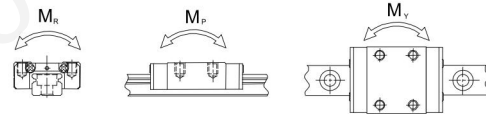
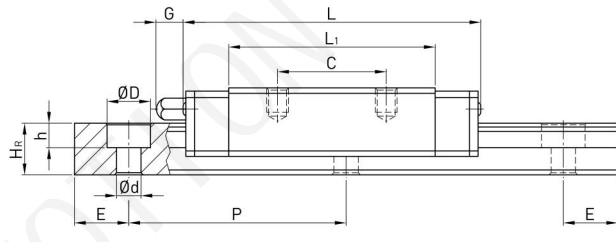
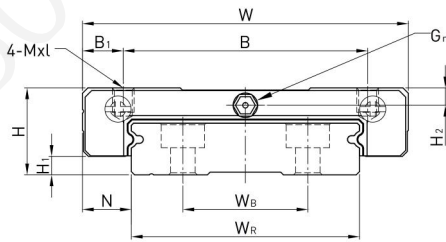

Model	Component size			Slider size(MM)										Slide rail size(MM)										Slide rail fixing bolt dimensions (mm)	Basic dynamic load rating C(kN)	Basic static load rating Co (kN)	Allowable static moment			weight	
	H	H ₁	N	W	B	B ₁	C	L ₁	L	G	G	MxL	H ₂	W _R	W	H _R	D	h	d	P	E	M	M				M _y	slider kg	guide kg/m		
YSS 3WS	4.5	1	3	12	-	-	4.5	10	15.2	-	-	M2x1.4	-	6	-	2.6	4	1.5	2.4	15	-	M2x1	0.29	0.54	1.6	0.9	0.9	-	-		
YSS 5WN	-	-	-	-	-	-	8	15.1	20.1	-	-	-	-	-	-	-	-	-	-	-	-	0.38	0.91	2.6	1.9	1.9	-	-			
YSS 5WS	6.5	1.5	3.5	17	13	2	-	13.6	20.6	-	-	M2.5x2	-	10	-	4	4.8	1.6	2.9	20	75	M2.5x6	0.48	0.92	4.7	2.2	2.2	-	-		
YSS 5WN	-	-	-	-	-	-	-	17.6	24.6	-	-	-	-	-	-	-	-	-	-	-	-	0.63	1.34	7.0	4.2	4.2	-	-			
YSS 7WS	9	1.9	5.5	25	19	3	10	21	31.2	-	φ1.2	M3x3	1.85	14	-	5.2	6	3.2	3.5	30	10	M3x6	1.37	2.06	15.7	7.4	7.4	0.020	0.51		
YSS 7WN	-	-	-	-	-	-	19	30.8	41	-	-	-	-	-	-	-	-	-	-	-	-	1.77	3.14	23.45	15.53	15.53	0.029	-			
YSS 9WS	12	2.9	6	30	21	4.5	12	27.5	39.3	-	φ1.4	M3x3	2.4	18	-	7	6	4.5	3.5	30	10	M3x8	2.75	4.12	40.12	18.96	18.96	0.040	0.91		
YSS 9WN	-	-	-	-	23	3.5	24	38.5	50.7	-	-	-	-	-	-	-	-	-	-	-	-	3.43	5.89	54.54	34	54.00	0.057	-			
YSS 12WS	14	3.4	8	40	28	6	15	31.3	46.1	-	φ1.4	M3x3.6	2.8	24	-	8.5	8	4.5	4.5	40	15	M4x8	3.92	5.59	70.34	27.8	27.80	0.071	1.49		
YSS 12WN	-	-	-	-	-	-	28	45.6	60.4	-	-	-	-	-	-	-	-	-	-	-	-	5.10	8.24	102.70	57.37	57.37	0.103	-			
YSS 15WS	16	3.4	9	60	45	7.5	20	38	54.8	-	-	M4x4.2	3.2	42	23	9.5	8	4.5	4.5	40	15	M4x10	6.77	9.22	199.34	56.66	56.66	0.143	2.86		
YSS 15WN	-	-	-	-	-	-	35	57	73.8	-	5.2	M5	4.2	42	23	9.5	8	4.5	4.5	40	15	M4x10	8.93	13.38	299.01	120.60	122.60	0.215	-		

Note: 1kgf=9.81N

PGH Steel Strip Linear Guide

2-5-1 The Structure of PGH-series

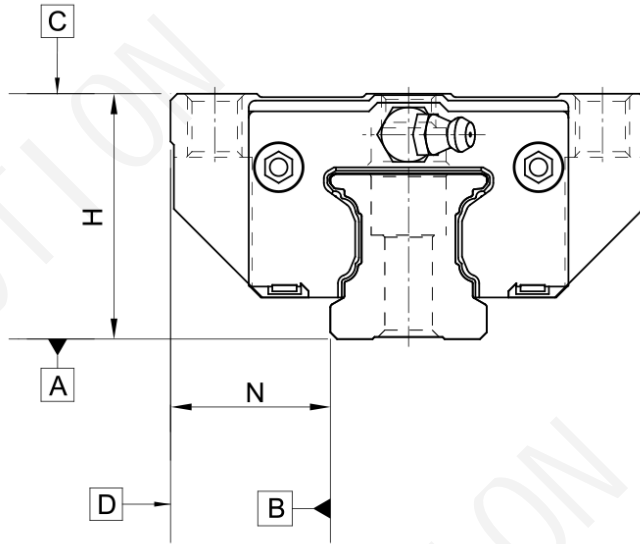

- Rolling circulation system: Block, rail, ball, end cap and retainer
- Lubrication system: Grease Nipple and Piping Joint
- Dust protection system: End seal, Bottom Seal, Bolt Cap, Metal scraper



YOSO offers standard rail lengths for customer needs. For non-standard E-values, the recommended dimension should not be greater than 1/2 of the pitch (P) dimension. This will prevent an unstable rail end.

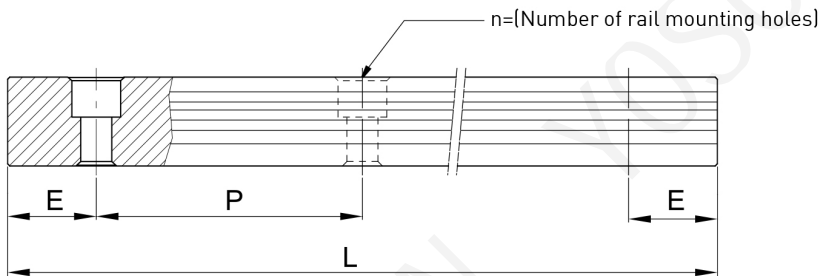

$$L = (n - 1) \times P + 2 \times E \quad \text{Eq.2.1}$$

L : Total length of rail (mm)

P : Distance between any two holes (mm)

n : Number of mounting holes

E : Distance from the center of the last hole to the edge (mm)

YOSO MOTION LINEAR GUIDE RAIL

PGH Steel Strip Linear Guide

2-5-2 Nominal Model Code of PGH Type

PGH Series can be classified into interchangeable and non-interchangeable types. The sizes are identical; the only difference between the two types is that the accuracy of non-interchangeable types could reach up to UP grades since YOSO MOTION makes the linear guide set under strict international regulation. Interchangeable blocks and rails can be freely exchanged, however, the accuracy could be up to H grade only due to technical issues. It is much more convenient for customers who do not need linear guides with high accuracy to have interchangeable blocks and rails.

Non-interchangeable Type code:

PGH 25 L C/R - 2 - - 1200 - N - Z0 - II - U + N3 N3

①
②
③
④
⑤
⑥
⑦
⑧
⑨
⑩
⑪
⑫
⑬

① Nominal Model	② Dimension
PGH	15,20,25,30,35,45

③ Length of Block	④ Flange Type	⑤ Number of Block Per Rail	⑥ Accessory Code
N: Normal L: Long	C: With Flange R: Quartet	EX: 2	<input type="checkbox"/> : Standard (Please refer to page A26)

⑦ Length of Rail	⑧ Accuracy Grade	⑨ Preload	⑩ Two Sets per Axis	⑪ Rail Special Machining
Unit: mm	N: Normal H: High P: Precision SP: Super-Precision UP: Ultra-Precision	ZF: Slight Clearance Z0: No Preload Z1: Light Preload Z2: Medium Preload Z3: Heavy Preload	II	U: Tapped-Hole Rail E: Rail with Special Machining

⑫ Block Surface Treatment	⑬ Rail Surface Treatment
S: Standard	S: Standard
B1: Black Oxidation	B1: Black Oxidation
N1: Hard Chrome Plating	N1: Hard Chrome Plating
P: Phosphating	P: Phosphating
N3: Nickel Plating	N3: Nickel Plating
N4: Raydent	N4: Raydent
N5: Chrome Plating	N5: Chrome Plating

No symbol required when plating is not needed

PGH Steel Strip Linear Guide

2-5-3 PGH-R/PGH-LR Series Specifications

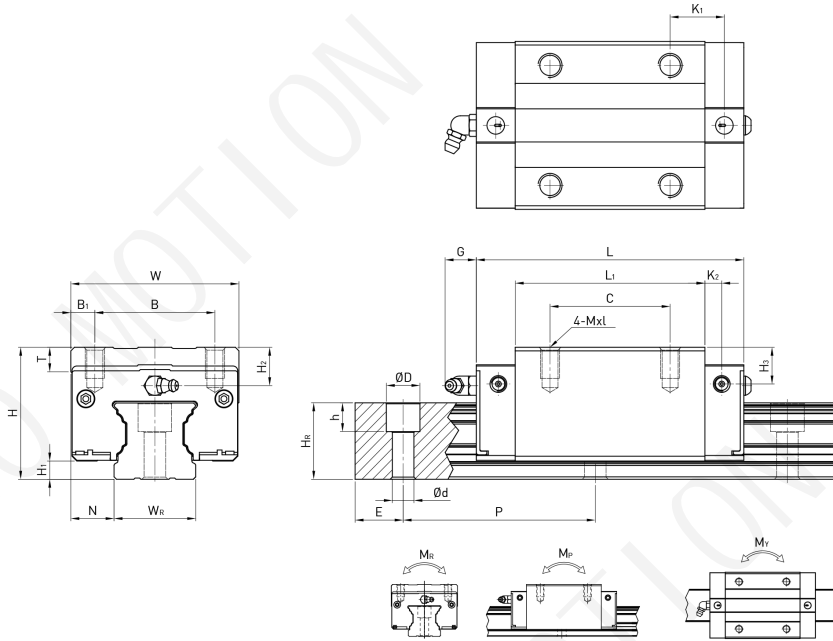

Model No.	Dimensions of Assembly (mm)			Dimensions of Block(mm)											Dimensions of Rail(mm)						Mounting Bolt for Rail (mm)	Basic Dynamic Load Rating C(kN)	Basic Static Load Rating Co(kN)	Static Rated Moment			Weight				
	H	H1	N	W	B	B1	C	L1	L	K1	K2	G	Mxl	T	H2	H3	Wr	Hr	D	h				d	P	E	Mr	Ms	My	Block kg	Rail kg/m
PGH15R	28	4.1	9.5	34	26	4	26	39.6	58.2	10.8	4.25	6	M4x6	6	7.8	7.8	15	16.2	7.5	5.9	4.5	60	20	M4x17	14.7	19.52	0.19	0.14	0.14	0.15	1.58
PGH20R	30	4.65	12	44	32	6	36	52.5	74.9	12.45	5.5	6	M5x6	8	3.7	4	20	20.55	9.5	8.5	6	60	20	M5x19	23.7	30.51	0.37	0.28	0.28	0.25	2.48
PGH20LR							50	68.5	90.9	13.45															40.5	54.08	0.74	0.73	0.73	0.59	
PGH25R	40	6.1	12.5	48	35	6.5	35	61	84	17.4	5	13	M6x8	8	10	91	23	24.25	11	9	7	60	20	M6x22	34.96	43.94	0.6	0.49	0.49	0.46	3.38
PGH25LR							50	78.4	101.4	18.6															40.5	54.08	0.74	0.73	0.73	0.59	
PGH30R	45	7	16	60	40	10	40	69	97.4	19.75	8.7	13	M8x10	9.5	9.7	9.7	28	28.35	14	12	9	80	20	M8x25	46	55.19	0.95	0.7	0.7	0.71	5.1
PGH30LR							60	91.5	119.9	21															58.59	78.18	1.35	1.23	1.23	0.94	
PGH35R	55	7.6	18	70	50	10	50	79	111.4	22.6	7	13	M8x13	10.2	16	15.3	34	31.85	14	12	9	80	20	M8x28	61.17	79.3	1.73	1.09	1.09	1.24	7.14
PGH35LR							72	103.4	135.8	23.8															77.9	112.34	2.46	2.02	2.02	1.62	
PGH45R	70	9.7	20.5	86	60	13	60	97.2	137.6	23	8.7	13	M10x17	16	18.5	18.5	45	39.85	20	17	14	105	22.5	M12x37	98.43	112.66	3.56	2.35	2.35	2.38	11.51
PGH45LR							80	133.6	174	31.2															125.58	159.6	5.05	4.45	4.45	3.01	

Note : 1 kgf = 9.81 N

YOSO MOTION LINEAR GUIDE RAIL

PGH Steel Strip Linear Guide

2-5-4 PGH-C/PGH-LC Series Specifications

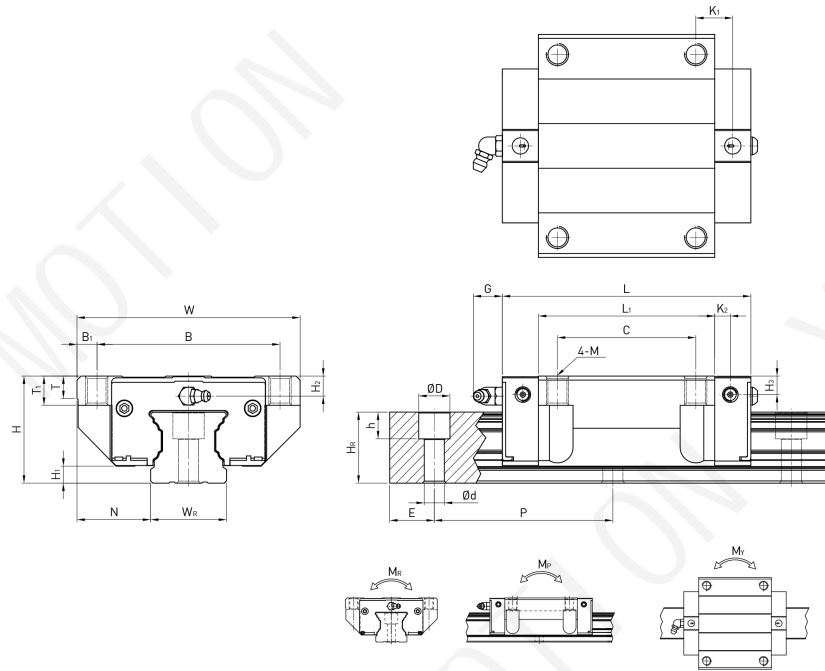

Model No.	Dimensions of Assembly (mm)			Dimensions of Block(mm)													Dimensions of Rail(mm)										Mounting Bolt for Rail (mm)	Basic Dynamic Load Rating C(kN)	Basic Static Load Rating Co(kN)	Static Rated Moment			Weight	
	H	H1	N	W	B	B1	C	L1	L	K1	K2	G	M	T	T1	H2	H3	Wc	Hc	D	h	d	P	E	Mx (kN-m)	My (kN-m)				Mz (kN-m)	Block kg	Rail kg/m		
PGH15C	24	4.1	16	47	38	4.5	30	39.6	58.2	8.8	4.25	6	M5	6	6.5	3.8	3.8	15	16.2	7.5	5.9	4.5	60	20	M4x17	14.7	19.52	0.19	0.14	0.14	0.14	0.14	1.58	
PGH20C	30	4.65	21.5	63	53	5	40	52.5	74.9	10.45	5.5	6	M6	6.5	7.7	3.7	4	20	20.55	9.5	8.5	6	60	20	M5x19	23.7	30.51	0.37	0.28	0.28	0.36	2.48		
PGH20LC								68.5	90.9	18.45																28.6	39.9	0.48	0.48	0.48	0.47			
PGH25C	36	6.1	23.5	70	57	6.5	45	61	84	12.4	5	13	M8	7	9.3	6	5.1	23	24.25	11	9	7	60	20	M6x22	34.96	43.94	0.6	0.49	0.49	0.53	3.38		
PGH25LC								78.4	101.4	21.1																40.5	54.08	0.74	0.73	0.73	0.68			
PGH30C	42	7	31	90	72	9	52	69	97.4	13.75	8.7	13	M10	10.5	12	6.7	6.7	28	28.35	14	12	9	80	20	M8x25	46	55.19	0.95	0.7	0.7	0.9	5.1		
PGH30LC								91.5	119.9	25																58.59	78.18	1.35	1.23	1.23	1.19			
PGH35C	48	7.6	33	100	82	9	62	79	111.4	16.6	7	13	M10	10.1	13.1	9	8.3	34	31.85	14	12	9	80	20	M8x28	61.17	79.3	1.73	1.09	1.09	1.37	7.14		
PGH35LC								103.4	135.8	28.8																77.9	112.34	2.46	2.02	2.02	1.79			
PGH45C	60	9.7	37.5	120	100	10	80	97.2	137.6	13	8.7	13	M12	13.5	15	8.5	8.5	45	39.85	20	17	14	105	22.5	M12x37	98.43	112.66	3.56	2.35	2.35	2.45	11.51		
PGH45LC								133.6	174	31.2																125.58	159.6	5.05	4.45	4.45	3			

Note : 1 kgf = 9.81 N

YGG Series -High Rigidity RollerType Linear Guideway

2-6-1 Advantages and features

The new YGG series from YOSO features a roller as the rolling element instead of steel balls. The roller series offers superior high rigidity and very high load capacities. The YGG series is designed with a 45-degree angle of contact. Elastic deformation of the linear contact surface, during load, is greatly reduced thereby offering greater rigidity and higher load capacities in all 4 load directions. The YGG series linear guideway offers high performance for high-precision manufacturing and achieving longer service life.

(1) Optimal design

FEM analysis was performed to determine the optimal structure of the block and the rail. The unique design of the circulation path allows the YGG series linear guideway to offer smoother linear motion.

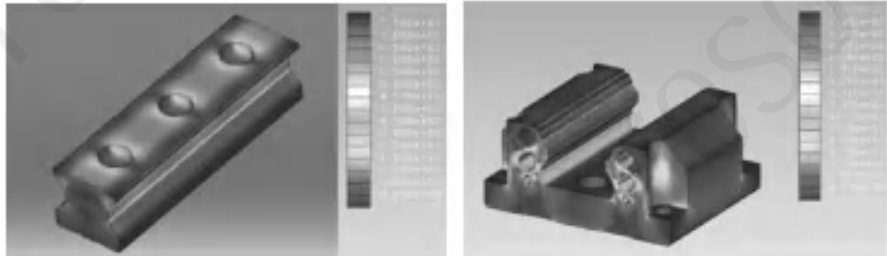

(2) Super high rigidity

The YGG series is a type of linear guideway that uses rollers as the rolling elements. Rollers have a greater contact area than balls so that the roller guideway features higher load capacity and greater rigidity. The figure shows the rigidity of a roller and a ball with equal volume.

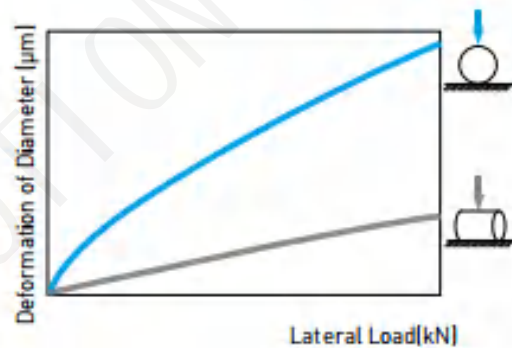

(3) Super high load capacity

With the four rows of rollers arranged at a contact angle of 45 degrees, the YGG series linear guideway has equal load ratings in the radial, reverse radial and lateral directions. The YGG series has a higher load capacity in a smaller size than conventional, ball-type linear guideways.

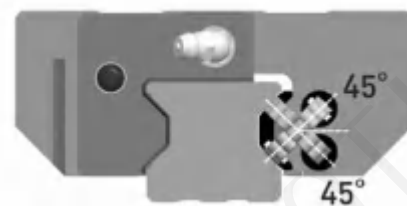

(4) Operating life increased

Compare with the ball element, the contact pressure of the rolling element is distributed on the line region. Therefore, stress concentration was reduced significantly and the YGG series offers longer running life. The nominal life of the YGG series can be calculated by using Eq.

The acting load will affect the nominal life of a linear guideway. Based on the selected basic dynamic rated load and the actual load. The nominal life of ball type and roller type linear guideway can be calculated by Eq. 2.5 respectively.

$$L = \left(\frac{C}{P} \right)^{\frac{10}{3}} \cdot 100 \text{ km} = \left(\frac{C}{P} \right)^{\frac{10}{3}} \cdot 62 \text{ mile} \quad \text{Eq. 2.5}$$

If the environmental factors are taken into consideration, the nominal life is influenced greatly by the motion conditions, the hardness of the raceway, and the temperature of the linear guideway. The relationship between the factors is expressed in Eq. 2.6.

$$L = \left(\frac{f_h \cdot f_t \cdot C}{f_w \cdot P} \right)^{\frac{10}{3}} \cdot 100 \text{ km} = \left(\frac{f_h \cdot f_t \cdot C}{f_w \cdot P} \right)^{\frac{10}{3}} \cdot 62 \text{ mile} \quad \text{Eq. 2.6}$$

- | | |
|-------------------------------|----------------------------|
| L : Nominal life | f_h : Hardness factor |
| C : Basic dynamic load rating | f_t : Temperature factor |
| P : Actual load | f_w : Load factor |

YOSO MOTION LINEAR GUIDE RAIL

YGG Series -High Rigidity Roller Type Linear Guideway

1. Nominal life test

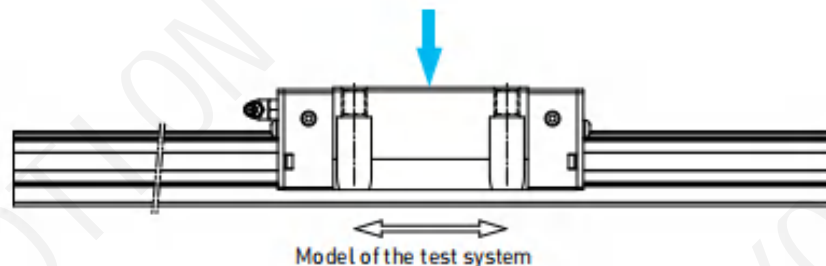



Table 2-6-1

<p>Tested model1: YGG35R</p> <p>Preload: ZA class Max.Speed: 60mmin Acceleration: 1G Stroke: 0.55m Lubrication: grease held every 100km External load: 15kN Traveling distance: 1135km</p>	<p>Test results:</p> <p>The nominal life of YGG35Ris 1000km.After traveling 1135km, fatigue flaking did not appear on the surface of the raceway or rollers,</p> 
---	---

2. Durability Test

<p>Tested model2: YGG35C</p> <p>Preload: ZA class Max.Speed: 120mmin Acceleration: 1G Stroke: 2m Lubrication: oil feed rate: 0.3cm³/hr External load: 0kN Traveling distance: 15000km</p>	<p>Test results:</p> <p>Fatigue flaking did not appear on the surface of the raceway or rollers after traveling 15000km.</p> 
---	--

Note:The datalistd are from samples.

2-6-2 Construction of YGG Series

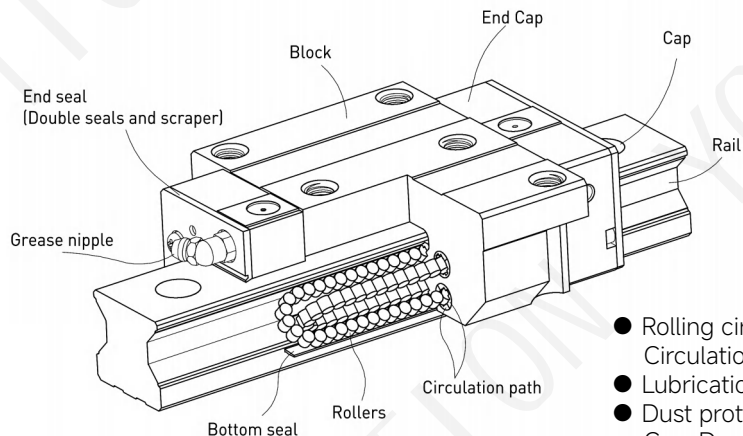

- Rolling circulation system: Block, Rail, End ca p, Circulation path, rollers
- Lubrication system: Grease nipple and piping joint
- Dust protection system: End seal, Bottom seal, Cap, Double seals and Scraper

YGG Series -High Rigidity RollerType Linear Guideway

2-6-3 Model Number of YGG series

YGG series linear guideways are classified into non-interchangeable and interchangeable types. The sizes of these two types are the same as one another. The main difference is that the interchangeable type of blocks and rails can be freely exchanged and they can maintain P-class accuracy. Because of strict dimensional control, the interchangeable type linear guideways are a wise choice for customers when rails do not need to be matched for an axis. The model number of the YGG series identifies the size, type, accuracy class, preload class, etc.

(1) Non-interchangeable type

YGG 25 L C/R - 2 - - 1200 - N - Z0 - II - U + N3 N3

①
②
③
④
⑤
⑥
⑦
⑧
⑨
⑩
⑪
⑫
⑬

① Nominal Model	② Dimension
YGG	15,20,25,30,35,45,55,65

③ Length of Block	④ Flange Type	⑤ Number of Block Per Rail	⑥ Accessory Code
N:Normal L:Long	C:WithFlange R:Quartet	EX:2	<input type="checkbox"/> :Standard (Please refer to page A26)

⑦ Length of Rai	⑧ Accuracy Grade	⑨ Preload	⑩ Two Sets per Axis	⑪ Rail Special Machining
Unit:mm	N:Norma H:High P:Precision SP:Super-Precision UP:Ultra-Precision	ZF:Slight Clearance Z0:No Preload Z1:Light Preload Z2:Medium Preload Z3:Heavy Preload	II	U:Tapped-Hole Rail E:Rail with Special Machining

⑫ Block Surface Treatment	⑬ Rail Surface Treatment
S:Standard	S:Standard
B1:Black Oxidation	B1:Black Oxidation
N1:Hard Chrome Plating	N1:Hard Chrome Plating
P:Phosphating	P:Phosphating
N3:Nickel Plating	N3:Nickel Plating
N4:Raydent	N4:Raydent
N5:Chrome Plating	N5:Chrome Plating

No symbol required when plating is not needed

YOSO MOTION LINEAR GUIDE RAIL

YGG Series -High Rigidity Roller Type Linear Guideway

2-6-4 Advantages and features

(1) Block types

YOSO offers two types of guide blocks, flange and square type. Because of the low assembly height and large mounting surface, the flange type is excellent for heavy moment load applications.

Table 2-6-2

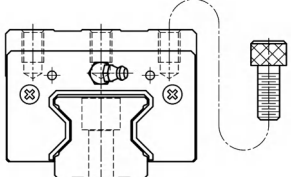
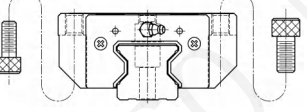
Type	Model	Shape	Height	Rail Length	Main Application
Square	YGG-R		28	100	<ul style="list-style-type: none"> ● Automation Systems ● Transportation equipment ● CNC machining centers ● Heavy duty cutting machines ● CNC grinding machines ● Injection molding machines ● Plano millers ● Devices requiring high rigidity ● Devices requiring high load capacity ● Electric discharge machines
	YGG-LR		90	4000	
Flange	YGG-C		24	100	
	YGG-LC		90	4000	

(2) Rail types

In addition to the standard top mounting type, YOSO also offers the bottom mounting type of rails.

Table 2-6-3

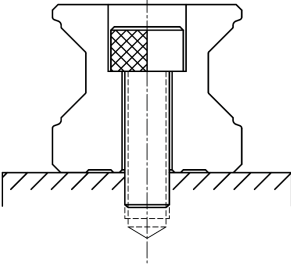
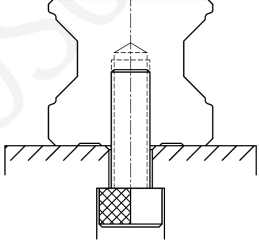
Mounting from Top	Mounting from Bottom
	

YGG Series -High Rigidity RollerType Linear Guideway

2-6-5 Accuracy Classes

The accuracy of the YGG series can be classified into four classes: high (H), precision (P), super precision (SP) and ultra precision (UP). Customers may choose the class by referencing the accuracy requirements of the applied equipment.

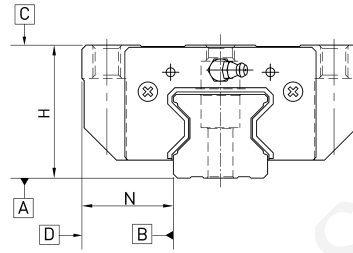

(1) Non-interchangeable type

Table 2-6-4 Accuracy Standards

Item	YGG-15,20			
	High	Precision	Super Precision	Ultra Precision
	(C)	(P)	(SP)	(UP)
Dimensional tolerance of height H	±0.03	0 -0.03	0 -0.015	0 -0.008
Dimensional tolerance of width N	±0.03	0 -0.03	0 -0.015	0 -0.008
Variation of height H	0.01	0.006	0.004	0.003
Variation of width N	0.01	0.006	0.004	0.003
Running parallelism of block surface C to surface A	See Table 2-5-12			
Running parallelism of block surface D to surface B	See Table 2-5-12			

Table 2-6-5 Accuracy Standards

Item	YGG-25,30,35			
	High	Precision	Super Precision	Ultra Precision
	(C)	(P)	(SP)	(UP)
Dimensional tolerance of height H	±0.04	0 -0.04	0 -0.02	0 -0.01
Dimensional tolerance of width N	±0.04	0 -0.04	0 -0.02	0 -0.01
Variation of height H	0.015	0.007	0.005	0.003
Variation of width N	0.015	0.007	0.005	0.003
Running parallelism of block surface C to surface A	See Table 2-5-12			
Running parallelism of block surface D to surface B	See Table 2-5-12			

YOSO MOTION LINEAR GUIDE RAIL

YGG Series -High Rigidity Roller Type Linear Guideway

Table 2-6-6 Accuracy Standards

Item	YGG-45,55			
	High	Precision	Super Precision	Ultra Precision
	(C)	(P)	(SP)	(UP)
Dimensional tolerance of height H	±0.05	0 -0.05	0 -0.03	0 -0.02
Dimensional tolerance of width N	±0.05	0 -0.05	0 -0.03	0 -0.02
Variation of height H	0.015	0.007	0.005	0.003
Variation of width N	0.02	0.01	0.007	0.003
Running parallelism of block surface C to surface A	See Table 2-5-12			
Running parallelism of block surface D to surface B	See Table 2-5-12			

Table 2-6-7 Accuracy Standards

Item	YGG-65			
	High	Precision	Super Precision	Ultra Precision
	(C)	(P)	(SP)	(UP)
Dimensional tolerance of height H	±0.07	0 -0.07	0 -0.05	0 -0.03
Dimensional tolerance of width N	±0.07	0 -0.07	0 -0.05	0 -0.03
Variation of height H	0.02	0.01	0.007	0.005
Variation of width N	0.025	0.015	0.01	0.007
Running parallelism of block surface C to surface A	See Table 2-5-12			
Running parallelism of block surface D to surface B	See Table 2-5-12			

(2) Accuracy of interchangeable

Table 2-6-8 Accuracy Standards

Item	YGG-15,20	
	High(H)	Precision(P)
Dimensional tolerance of height H	±0.03	-0.015
Dimensional tolerance of width N	±0.03	-0.015
Variation of height H	0.01	0.006
Variation of width N	0.01	0.006
Running parallelism of block surface C to surface A	See Table 2-5-12	
Running parallelism of block surface D to surface B	See Table 2-5-12	

YGG Series -High Rigidity RollerType Linear Guideway

Table 2-6-9 Accuracy Standards

Item	YGG-25,30,35	
Accuracy Classes	High(H)	Precision(P)
Dimensional tolerance of height H	±0.04	-0.02
Dimensional tolerance of width N	±0.04	-0.02
Variation of height H	0.015	0.007
Variation of width N	0.015	0.007
Running parallelism of block surface C to surface A	See Table 2-5-12	
Running parallelism of block surface D to surface B	See Table 2-5-12	

Table 2-6-10 Accuracy Standards

Item	YGG-45,55	
Accuracy Classes	High(H)	Precision(P)
Dimensional tolerance of height H	±0.05	-0.025
Dimensional tolerance of width N	±0.05	-0.025
Variation of height H	0.015	0.007
Variation of width N	0.02	0.01
Running parallelism of block surface C to surface A	See Table 2-5-12	
Running parallelism of block surface D to surface B	See Table 2-5-12	

Table 2-6-11 Accuracy Standards

Item	YGG-65	
Accuracy Classes	High(H)	Precision(P)
Dimensional tolerance of height H	±0.07	-0.035
Dimensional tolerance of width N	±0.07	-0.035
Variation of height H	0.02	0.01
Variation of width N	0.025	0.015
Running parallelism of block surface C to surface A	See Table 2-5-12	
Running parallelism of block surface D to surface B	See Table 2-5-12	

YOSO MOTION LINEAR GUIDE RAIL

YGG Series -High Rigidity Roller Type Linear Guideway

(3) Accuracy of running parallelism

Table 2-6-12 Accuracy of Running Parallelism

Rail Length (mm)	Accuracy (μm)			
	h	p	SP	UP
100	3	3	2	2
100~200	4	4	2	2
200~300	5	5	3	2
300~500	6	6	3	2
500~700	7	7	4	2
700~900	8	8	5	3
900~1,100	9	9	6	3
1,100~1,500	11	11	7	4
1,500~1,900	13	13	8	4
1,900~2,500	15	15	10	5
2,500~3,100	18	18	11	6
3,100~3,600	20	20	14	7
3,600~4,000	21	21	15	7

2-6-6 Preload

A preload can be applied to each guideway using oversized rollers. Generally, a linear motion guideway has negative-clearance between the raceway and rollers to improve stiffness and maintain high precision. The YGG series lineal guideway offers three standard preloads for various applications and conditions.

Table 2-6-13

Class	Code	Preload	Condition
Light Preload	Z0	0.02C-0.04C	Certain load direction, low impact, low precision required
Medium Preload	ZA	0.07C-0.09C	High rigidity required, high precision required
Heavy Preload	ZB	0.12C-0.14C	Super high rigidity required, with vibration and impact

The figure shows the relationship between the rigidity, friction and nominal life. A preload no larger than ZA would be recommended for smaller model sizes to avoid over-preload affecting the life of the guideway.

● Stiffness performance

Stiffness depends on preload. The following table shows stiffness value of each size.

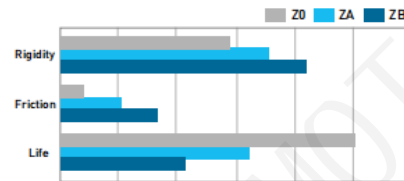

Table 2-6-14 Radial stiffness for YGG Series



Load type	Series/Size	Stiffness (N/ μm)		
		Z0	ZA	ZB
Heavy load	YGG 15C	508	727	788
	YGG 20C	625	853	950
	YGG 25C	692	954	1196
	YGG 30C	882	1082	1333
	YGG 35C	1059	1247	1547
	YGG 45C	1642	1851	2332
	YGG 55C	1784	2053	2506
	YGG 65C	2564	2900	3482
Super heavy load	YGG 20H	840	1160	1279
	YGG 25H	887	1242	1549
	YGG 30H	1125	1391	1711
	YGG 35H	1412	1757	2144
	YGG 45H	2207	2511	3172
	YGG 55H	2459	2858	3538
	YGG 65H	3560	4064	4937

YGG Series -High Rigidity RollerType Linear Guideway

2-6-7 Lubrication

(1) Grease

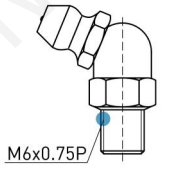
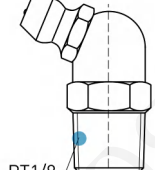
- Grease nipple

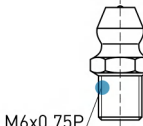
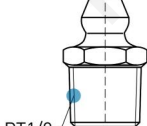
	 <p>YGG25 YGG30 YGG35</p> <p>M6x0.75P</p> <p>NO.34320001</p>	 <p>YGG45 YGG55 YGG65</p> <p>PT1/8</p> <p>NO.34320003</p>
 <p>YGG15 YGG20</p> <p>M4x0.7P</p> <p>NO.34310002</p>	 <p>YGG25 YGG30 YGG35</p> <p>M6x0.75P</p> <p>NO.34310008(OPTION)</p>	 <p>YGG45 YGG55 YGG65</p> <p>PT1/8</p> <p>NO.3431000B(OPTION)</p>

- Mounting location

The standard location of the grease fitting is at both ends of the block, but the nipple can be mounted in the side or the top of block. For lateral installation, we recommend that the nipple be mounted at the non-reference side, otherwise please contact us. It is possible to carry out the lubrication by using an oil-piping joint. The figure shows the locations of the grease fitting

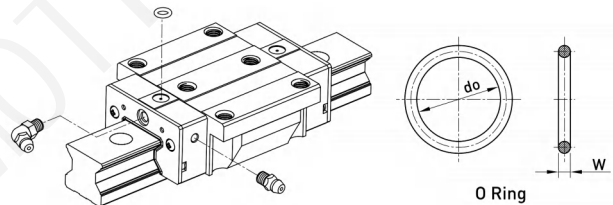
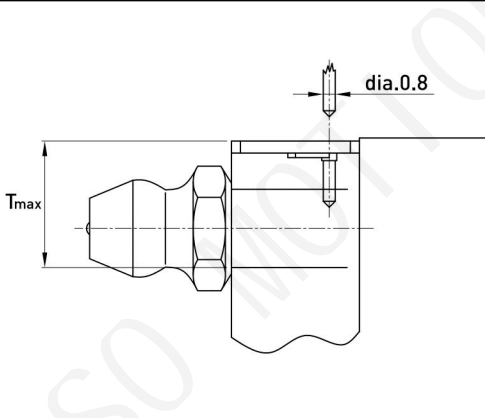

Table 2-6-15 O-Ring size and max. permissible depth for piercing

Size	O-Ring		Lube hole at top: max. permissible depth for piercing
	do (mm)	W(mm)	T _{max} (mm)
YGG15	2.5±0.15	1.5±0.15	3.45
YGG20	2.5±0.15	1.5±0.15	4
YGG25	7.5±0.15	1.5±0.15	5.8
YGG30	7.5±0.15	1.5±0.15	6.2
YGG35	7.5±0.15	1.5±0.15	8.65
YGG45	7.5±0.15	1.5±0.15	9.5
YGG55	7.5±0.15	1.5±0.15	11.6
YGG65	7.5±0.15	1.5±0.15	14.5



- The oil amount for a block filled with grease

Table 2-6-16 The oil amount for a block filled with grease

Size	Heavy Load(cm ³)	Super Heavy Load(cm ³)	Size	Heavy Load(cm ³)	Super Heavy Load(cm ³)
YGG15	3	-	YGG35	12	14
YGG20	5	6	YGG45	19	23
YGG25	7	8	YGG55	28	35
YGG30	9	10	YGG65	52	63

- Frequency of replenishment

Check the grease every 100 km, or every 3-6 months.

YOSO MOTION LINEAR GUIDE RAIL

YGG Series -High Rigidity Roller Type Linear Guideway

(2) Oil

The recommended viscosity of oil is about 32-150cSt. If you need to use oil-type lubrication, please inform us.

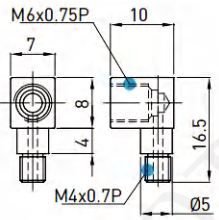
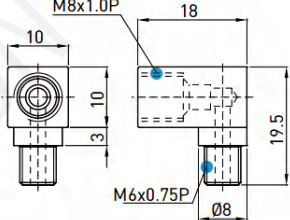
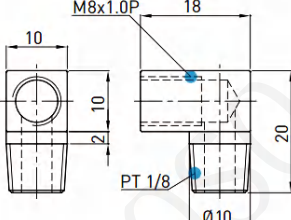
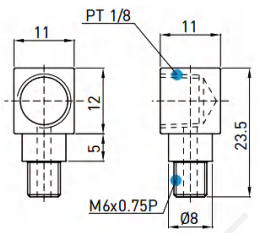
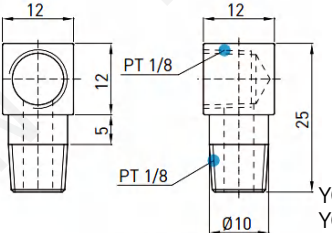
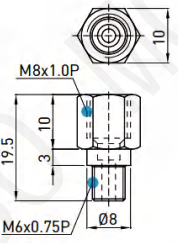
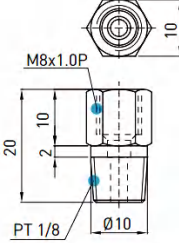
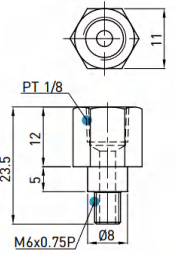
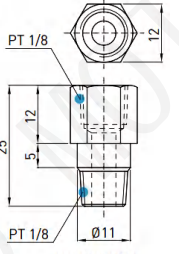
 <p>YGG15 YGG20</p> <p>NO.97000EA1</p>	 <p>YGG25 YGG30 YGG35</p> <p>NO.970002A1</p>	 <p>YGG45 YGG55 YGG65</p> <p>NO.970006A1</p>
	 <p>YGG25 YGG30 YGG35</p> <p>NO.970004A1</p>	 <p>YGG45 YGG55 YGG65</p> <p>NO.970008A1</p>
	 <p>YGG25 YGG30 YGG35</p> <p>NO.970001A1</p>	 <p>YGG45 YGG55 YGG65</p> <p>NO.970005A1</p>
	 <p>YGG25 YGG30 YGG35</p> <p>NO.970003A1</p>	 <p>YGG45 YGG55 YGG65</p> <p>NO.970007A1</p>

● Mounting location

Table 2-6-17 oil feed rate

Size	Feed rate (cm ³ /hr)	Size	Feed rate (cm ³ /hr)
YGG 15	0.14	YGG 35	0.23
YGG 20	0.14	YGG 45	0.3
YGG 25	0.167	YGG 55	0.367
YGG 30	0.2	YGG 65	0.433

YGG Series -High Rigidity RollerType Linear Guideway

2-6-8 Dust Proof Accessories

(1) Codes of accessories

If the following accessories are needed, please add the code followed by the model number.

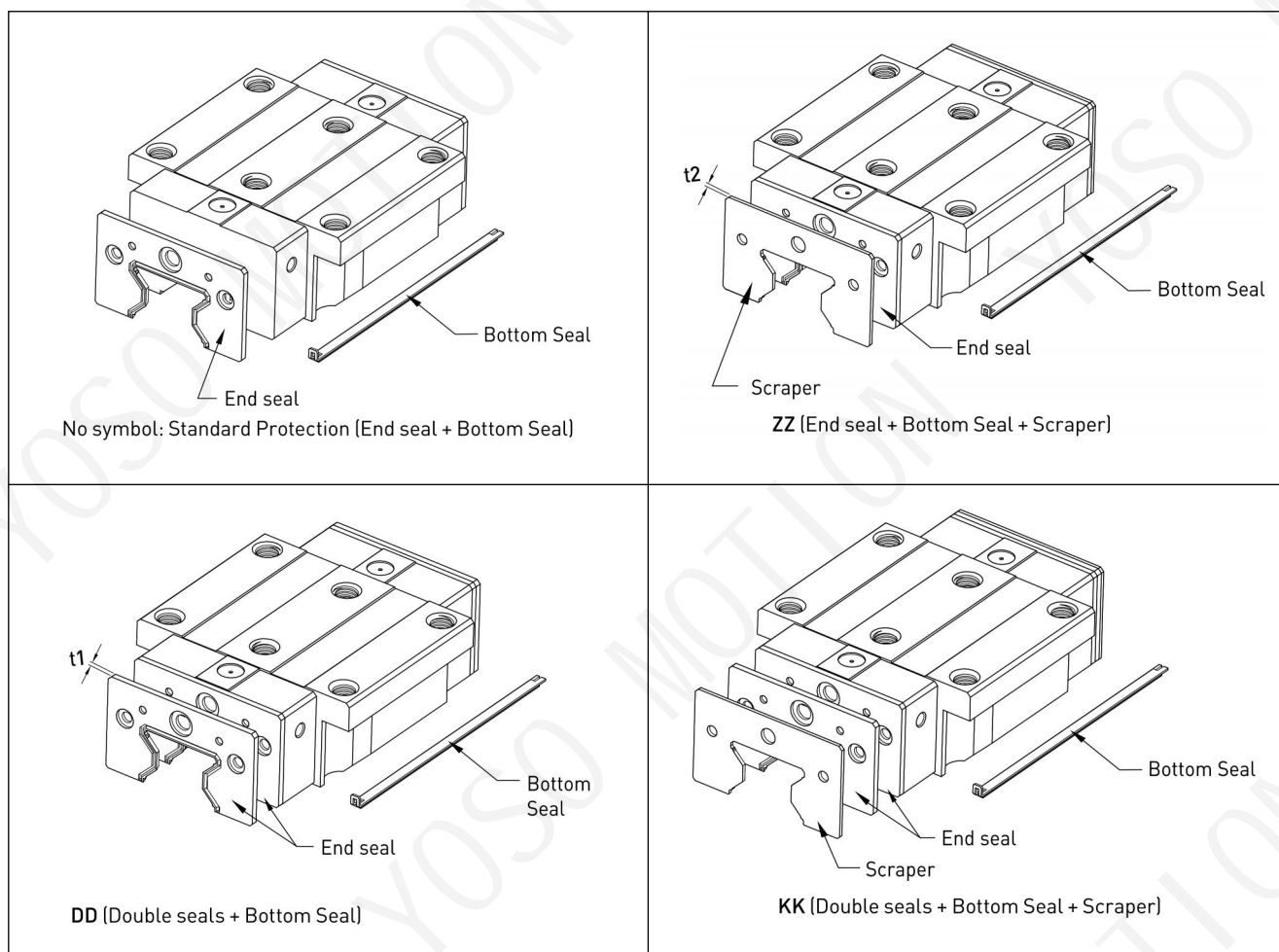

2-6-9 Friction

The maximum value of resistance per end seal are as shown in the table.

Table 2-6-18 Seal Resistance

Size	Resistance N (kgf)	Size	Resistance N (kgf)
YGG 15	2.45(0.25)	YGG 35	4.61(0.47)
YGG 20	2.9(0.3)	YGG 45	4.91(0.5)
YGG 25	3.43(0.35)	YGG 55	5.89(0.6)
YGG 30	4.22(0.43)	YGG 65	7.36(0.75)

Note:

1. 1kgf=9.81N

2. Please inform YOSO if lo friction request is required.

YOSO MOTION LINEAR GUIDE RAIL

YGG Series -High Rigidity Roller Type Linear Guideway

2-6-10 The Accuracy Tolerance of Mounting Surface

(1) The accuracy tolerance of rail-mounting surface

As long as the accuracy requirements of the mounting surfaces shown in the following tables are met, the high accuracy, high rigidity and long life of the YGG series linear guideway will be maintained without any difficulty.

- The parallelism tolerance of reference surface (P)

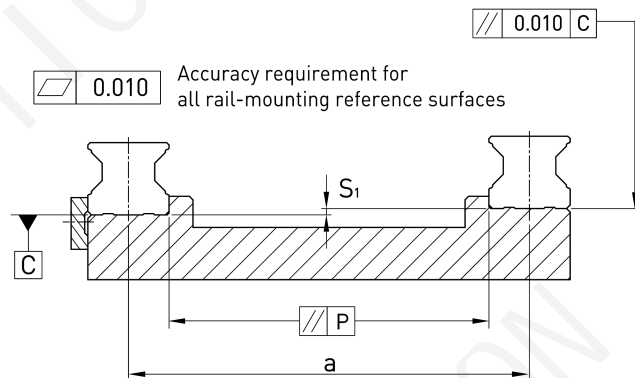

Table 2-6-19 Max. Parallelism Tolerance (P)

Size	Preload classes		
	Light Preload (Z0)	Medium Preload (ZA)	Heavy Preload (ZB)
YGG15	5	3	3
YGG20	8	6	4
YGG25	9	7	5
YGG30	11	8	6
YGG35	14	10	7
YGG45	17	13	9
YGG55	21	14	11
YGG65	27	18	14

- The accuracy tolerance of reference surface height (S_1)

$$S_1 = a \times K - T_H$$

S_1 : Max. tolerance of height

a : Distance between paired rails

K : Coefficient of tolerance of height

Table 4-1-20 Coefficient of tolerance of height

Size	Preload classes		
	Light Preload (Z0)	Medium Preload (ZA)	Heavy Preload (ZB)
k	2.2×10^{-4}	1.7×10^{-4}	1.2×10^{-4}

YGG Series -High Rigidity RollerType Linear Guideway

(2) The accuracy tolerance of block-mounting surface

- The tolerance of the height of reference surface when two or more pieces are used in parallel (S_2)

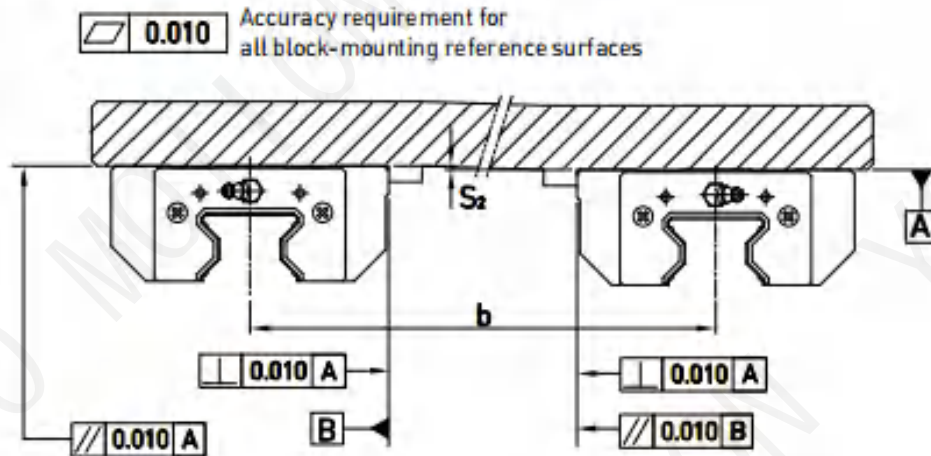

- The tolerance of the height of reference surface when two or more pieces are used in parallel (S_3)

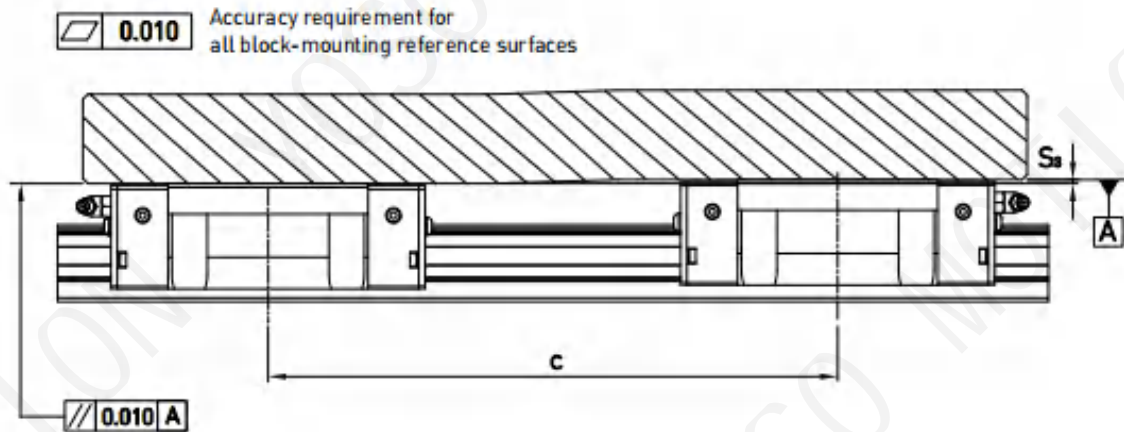

YGG Series -High Rigidity Roller Type Linear Guideway

2-6-11 Cautions for Installation

(1) Shoulder heights and fillets

Improper shoulder heights and fillets of mounting surfaces will cause a deviation in accuracy and the interference with the rail or block. As long as the recommended shoulder heights and fillets are followed, installation inaccuracies should be eliminated.

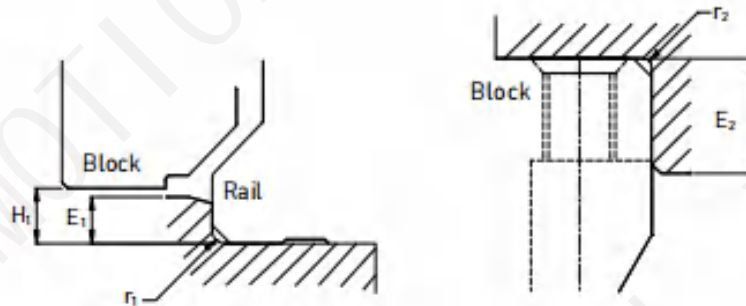

Table 2-6-21

Size	Max.radius of fillets r_1 (mm)	Max.radius of fillets r_2 (mm)	Shoulder height beside the rail r_1 (mm)	Shoulder height beside the block E_2 (mm)	Clearance under block H_1 (mm)
YGG15	0.5	0.5	3	4	4
YGG20	0.5	0.5	3.5	5	5
YGG25	1.0	1.0	5	5	5.5
YGG30	1.0	1.0	5	5	6
YGG35	1.0	1.0	6	6	6.5
YGG45	1.0	1.0	7	8	8
YGG55	1.5	1.5	9	10	10
YGG65	1.5	1.5	10	10	12

(2) Tightening Torque of Mounting Bolts

Improper tightening of mounting bolts will seriously influence the accuracy of a linear guideway. The following tightening torque for the different sizes of bolt is recommended.

Table 2-6-22

Size	Bolt size	Torque N-cm(kgf-cm)		
		Iron	Casting	Aluminum
YGG15	M4×0.7P×16L	392(40)	274(28)	206(21)
YGG20	M5×0.8P×20L	883(90)	588(60)	441(45)
YGG25	M6×1P×20L	1373(140)	921 (94)	686(70)
YGG30	M8×1.25P×25L	3041 (310)	2010 (205)	1470(150)
YGG35	M8×1.25P×25L	3041 (310)	2010 (205)	1470(150)
YGG45	M12×1.75P×35L	11772(1200)	7840 (800)	5880(600)
YGG55	M14×2P×45L	15696(1600)	10500(1100)	7840(800)
YGG65	M16×2P×50L	19620(2000)	13100(1350)	9800(1000)

YGG Series -High Rigidity RollerType Linear Guideway

2-6-12 Dimensions for YGG series

(1) YGG-R/YGG-LR

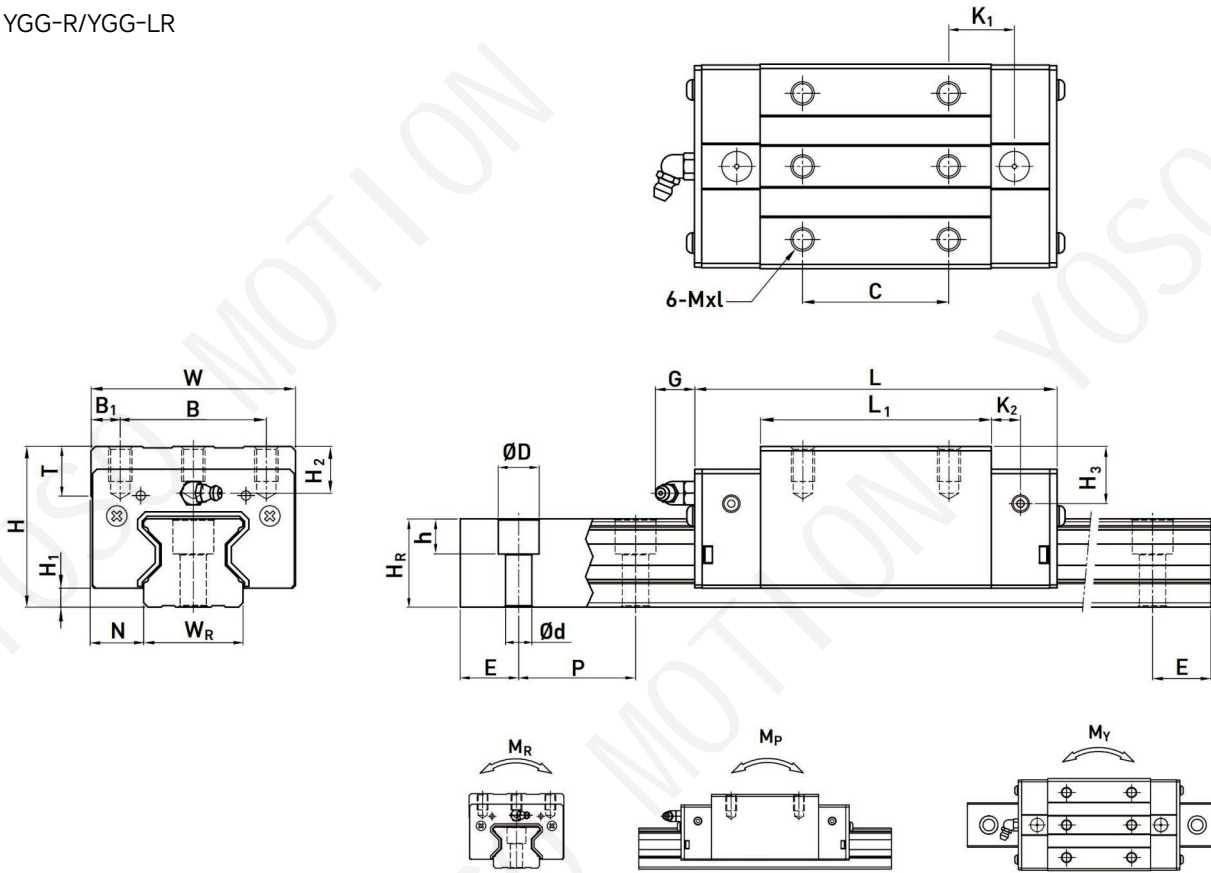

Model No.	Dimensions of Assembly (mm)		Dimensions of Block(mm)											Dimensions of Rail(mm)					Mounting Bolt for Rail (mm)	Basic Dynamic Load Rating C(kN)	Basic Static Load Rating Co(kN)	Static Rated Moment			Weight						
	H	H ₁	N	W	B	B ₁	C	L ₁	L	K ₁	K ₂	G	Mxl	T	H ₂	H ₃	W _R	H _R				D	h	d	P	E	M _R kN-m	M _P kN-m	M _Y kN-m	Block kg	Rail kg/m
YGG15R	28	4	9.5	34	26	4	26	45	68	13.4	4.7	5.3	M4x8	6	7.6	10.1	15	16.5	7.5	5.7	4.5	30	20	M4x16	11.3	24	0.311	0.173	0.173	0.2	1.8
YGG20R	34	5	12	44	32	6	36	57.5	86	15.8	6	5.3	M5x8	8	8.3	8.3	20	21	9.5	8.5	6	30	20	21.3	46.7	0.647	0.46	0.46	0.4	2.76	
YGG20LR							50	77.5	106	18.8														26.9	63	0.872	0.837	0.837	0.53		
YGG25R	40	5.5	12.5	48	35	6.5	35	64.5	97.9	20.75	7.25	12	M6x8	9.5	10.2	10	23	23.6	11	9	7	30	20	27.7	57.1	0.758	0.605	0.605	0.61	3.08	
YGG25LR							50	81	114.6	21.5														33.9	73.4	0.975	0.991	0.991	0.75		
YGG30R	45	6	16	60	40	10	40	71	109.8	23.5	8	12	M8x10	9.5	9.5	10.3	28	28	14	12	9	40	20	39.1	82.1	1.445	1.06	1.06	0.9	4.41	
YGG30LR							60	93	131.8	24.5														48.1	105	1.846	1.712	1.712	1.16		
YGG35R	55	6.5	18	70	50	10	50	79	124	22.5	10	12	M8x12	12	16	19.6	34	30.2	14	12	9	40	20	57.9	105.2	2.17	1.44	1.44	1.57	6.06	
YGG35LR							72	106.5	151.5	25.25														73.1	142	2.93	2.6	2.6	2.06		
YGG45R	70	8	20.5	86	60	13	60	106	153.2	31	10	12.9	M10x17	16	20	24	45	38	20	17	14	52.5	22.5	92.6	178.8	4.52	3.05	3.05	3.18	9.97	
YGG45LR							80	139.8	187	37.9														116	230.9	6.33	5.47	5.47	4.13		
YGG55R	80	10	23.5	100	75	12.5	75	125.5	183.7	37.75	12.5	12.9	M12x18	17.5	22	27.5	53	44	23	20	16	60	30	130.5	252	8.01	5.4	5.4	4.89	13.98	
YGG55LR							95	173.8	232	51.9														167.8	348	11.15	10.25	10.25	6.68		
YGG65R	90	12	31.5	126	76	25	70	160	232	60.8	15.8	12.9	M16x20	25	15	15	63	53	26	22	18	75	35	213	411.6	16.2	11.59	11.59	8.89	20.22	
YGG65LR							120	223	295	67.3														275.3	572.7	22.55	22.17	22.17	12.13		

Note:

1.1 kgf=9.81N

2.The theoretical dynamic rated load is C_{100R},if necessary C_{50R} conversion formulais as follows:C_{50R}=1.23xC_{100R}

YOSO MOTION LINEAR GUIDE RAIL

YGG Series -High Rigidity Roller Type Linear Guideway

(1) YGG-C/YGG-LC

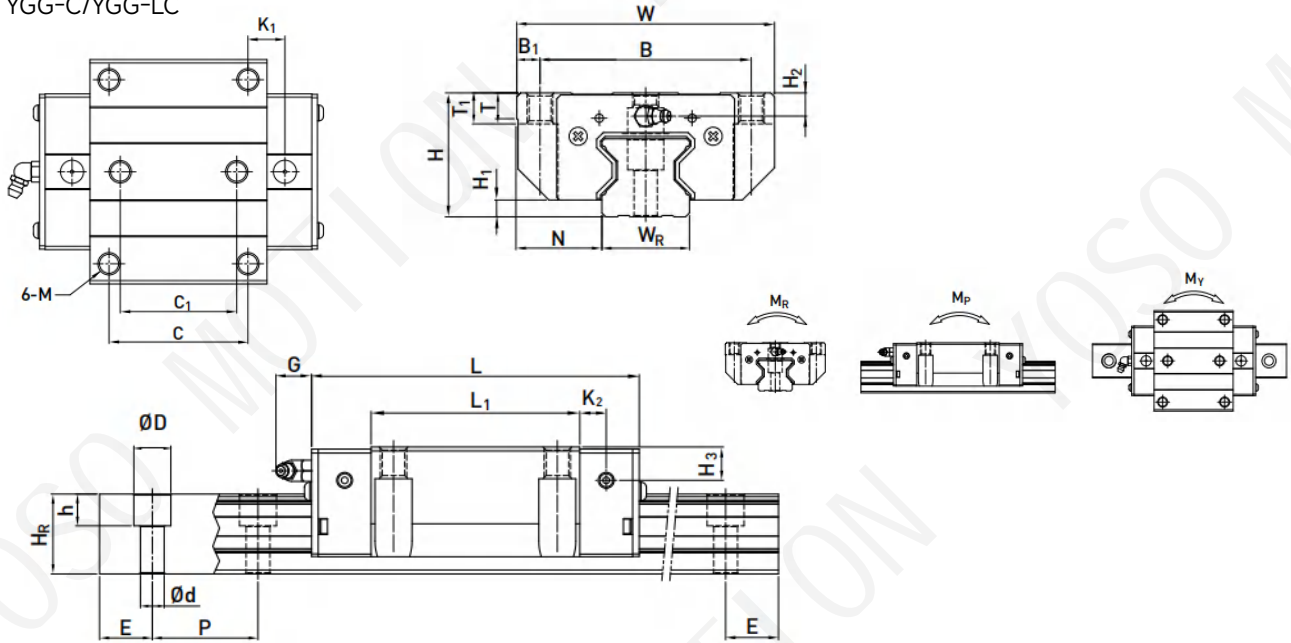

Model No.	Dimensions of Assembly (mm)				Dimensions of Block(mm)												Dimensions of Rail(mm)						Mounting Bolt for Rail (mm)	Basic Dynamic Load Rating C(kN)	Basic Static Load Rating Co(kN)	Static Rated Moment			Weight					
	H	Hi	N	W	B	B1	C	C1	L1	L	K1	K2	G	M	T	T1	H2	H3	Wr	Hr	D	h				d	P	E	MR	Mp	My	Block kg	Rail kg/m	
YGG15C	24	4	16	47	38	4.5	30	26	45	68	11.4	4.7	5.3	M5	6	6.95	3.6	6.1	15	16.5	7.5	5.7	4.5	30	20	M4x16	11.3	24	0.311	0.173	0.173	0.2	1.8	
YGG20C	30	5	21.5	63	53	5	40	35	57.5	86	13.8	6	5.3	M6	8	10	4.3	4.3	20	21	9.5	8.5	6	30	20	M5x20	21.3	46.7	0.647	0.46	0.46	0.4	2.76	
YGG20LC	30	5	21.5	63	53	5	40	35	77.5	106	23.8																							
YGG25C	36	5.5	23.5	70	57	6.5	45	40	64.5	97.9	15.75	7.25	12	M8	9.5	10	6.2	6	23	23.6	11	9	7	30	20	M6x20	27.7	57.1	0.758	0.605	0.605	0.61	3.08	
YGG25LC	36	5.5	23.5	70	57	6.5	45	40	81	114.6	24																							
YGG30C	42	6	31	90	72	9	52	44	71	109.8	17.5	8	12	M10	9.5	10	6.5	7.6	28	28	14	12	9	40	20	M8x20	39.1	82.1	1.445	1.06	1.06	0.9	4.41	
YGG30LC	42	6	31	90	72	9	52	44	93	131.8	28.5																							
YGG35C	48	6.5	33	100	82	9	62	52	79	124	16.5	10	12	M10	12	13	9	12.6	34	30.2	14	12	9	40	20	M8x25	57.9	105.2	2.17	1.44	1.44	1.57	6.06	
YGG35LC	48	6.5	33	100	82	9	62	52	106.5	151.5	30.25																							
YGG45C	60	8	37.5	120	100	10	80	60	106	153.2	21	10	12.9	M12	14	15	10	14	45	38	20	17	14	52.5	22.5	M12x35	92.6	178.8	4.52	3.05	3.05	3.18	9.97	
YGG45LC	60	8	37.5	120	100	10	80	60	139.8	187	37.9																							
YGG55C	70	10	43.5	140	116	12	95	70	125.5	183.7	27.75	12.5	12.9	M14	16	17	12	17.5	53	44	23	20	16	60	30	M14x45	130.5	252	8.01	5.4	5.4	4.89	13.98	
YGG55LC	70	10	43.5	140	116	12	95	70	173.8	232	51.9																							
YGG65C	90	12	53.5	170	142	14	110	82	160	232	40.8	15.8	12.9	M16	22	23	15	15	63	53	26	22	18	75	35	M16x50	213	411.6	16.2	11.59	11.59	8.89	20.22	
YGG65LC	90	12	53.5	170	142	14	110	82	223	295	72.3																							

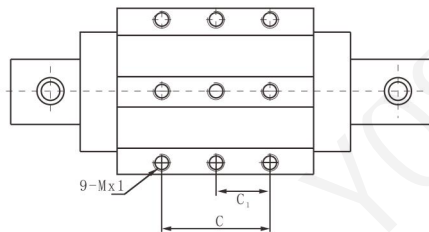

Model No.	Dimensions of Assembly (mm)				Dimensions of Block(mm)												Dimensions of Rail(mm)						Mounting Bolt for Rail (mm)	Basic Dynamic Load Rating C(kN)	Basic Static Load Rating Co(kN)	Static Rated Moment			Weight			
	H	Hi	N	W	B	B1	C	C1	L1	L	K1	G	M	T	T1	H2	H3	Wr	Hr	D	h	d				P	E	MR	Mp	My	Block kg	Rail kg/m
YGG85LC	110	15	65	215	185	-	140	70	254	349	-	14	M20	24	26	21	-	85	73	35	28	24	90	45	M20	460	945.2	45.6	45.6	51.42	21.6	35.2
YGG100LC	120	15	75	250	220	-	200	100	286	394	-	16	M20	25	30	23	-	100	80	39	32	26	105	52.5	M24	547	1330	61.2	61.2	73.14	31.5	46.8
YGG125LC	160	24.5	97.5	320	270	-	205	102.5	360	491	-	16	M20	30	45	23	-	125	115	48	45	33	120	60	M30	1040	1924	123.174	123.176	114.438	65.5	84.6

SE Type-Metal End Cap Linear Guideway

2-7-1 General Information

(1) Features

- Use of Metallic parts; (if end seal is needed, the high-temperature rubber in end seal is available)
- Excellent temperature resistance; service temperature under 150°C.

(2) Applications

- Heat treatment equipment,
- Applications using vacuums (no vapor dispersion from plastic or rubber)
- Welding equipment.

2-7-2 Structure

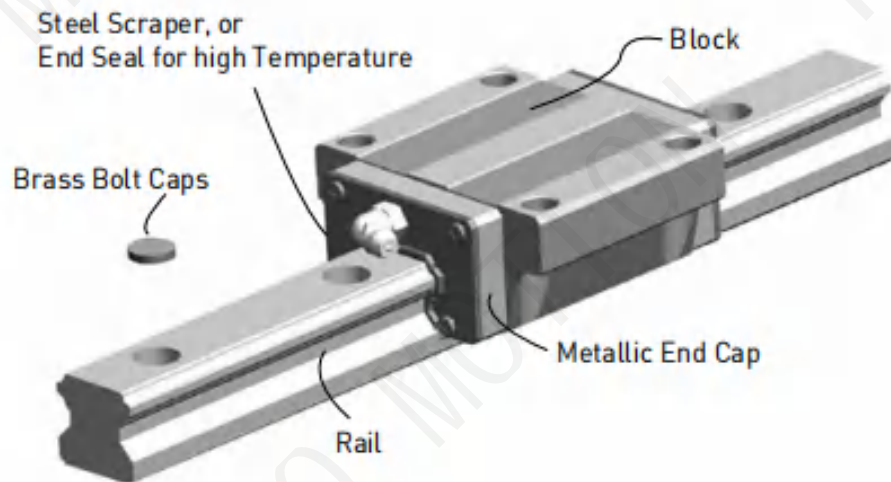

2-6-3 Specification

(1) Add "/SE" after the specification of linear guideway

YGH20LC21200NZ0IU+ N3/SE

2-7-4 Dimensions of Bolt Cap

Table 2-7-1 Dimensions of Copper Bolt Cap

Item	Bolt Size	Diameter (mm)		Item	Bolt Size	Diameter (mm)	
		D	H			D	H
C3-C	M3	6.15	1.2	C8-C	M8	14.15	3.5
C4-C	M4	7.65	1.2	C12-C	M12	20.15	4
C5-C	M5	9.65	2.5	C14-C	M14	23.15	4
C6-C	M6	11.15	2.8	C16-C	M16	24.15	4

Table 2-7-2 Dimensions of Stainless Bolt Cap

Item	Bolt Size	Diameter (mm)		Item	Bolt Size	Diameter (mm)	
		D	H			D	H
C3-S	M3	6.15	1.2	C8-S	M8	14.15	3.5
C4-S	M4	7.65	1.2	C12-S	M12	20.15	4
C5-S	M5	9.65	2.5	C14-S	M14	23.15	4
C6-S	M6	11.22	2.8	C16-S	M16	26.20	4

YOSO MOTION LINEAR GUIDE RAIL

Stainless Steel Linear Guideway

2-8-1 Features

- (1) Same features as standard linear guideway
 - Stiffness, Hardness, Service Life, Dimensions remain the same
- (2) Suitable for specific extreme environments
 - With metal components, it can be used in low and medium vacuum environments
- (3) Great corrosion resistance
 - Block, Rail, Steel Balls, Grease nipple, Screws are all made of stainless steel material

Note:

1. Currently available in YGH20C, YGH25C, YGH25R, YSR25C
2. Maximum length available is 2000mm
3. Add "/M" after the specification of linear guideway
Ex: YGH25CA2R1600ZAPI /M

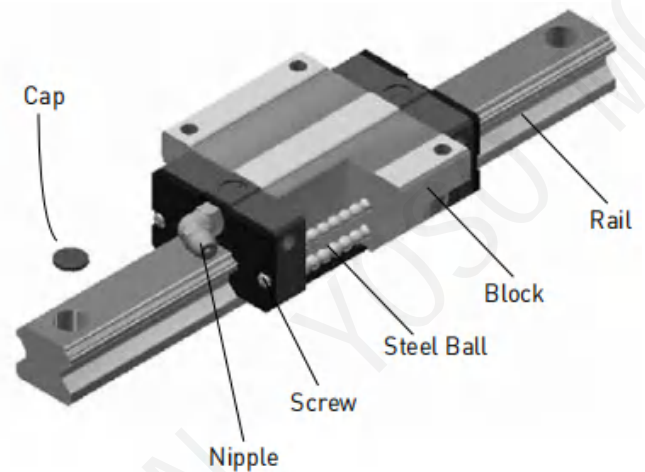

2-8-2 Suitable for below environments

- Chemicals
- Humid

2-8-3 Main Applications

- Food processing, transportation and storage
- Liquid and gas processing equipment
- Vacuum equipment
- Cleanroom equipment

Salt Spray Test		
	Stainless Steel Series	Regular Series
Before		
After		
Result	Slight Corrosion	Severe Corrosion

Note:

- Salt Solution: 5% NaCl
- Salt spray chamber temperature: 35°C±2°C
- Pressure: 1 bar

YS-CSR LM GUIDE CROSS LM GUIDE MODEL

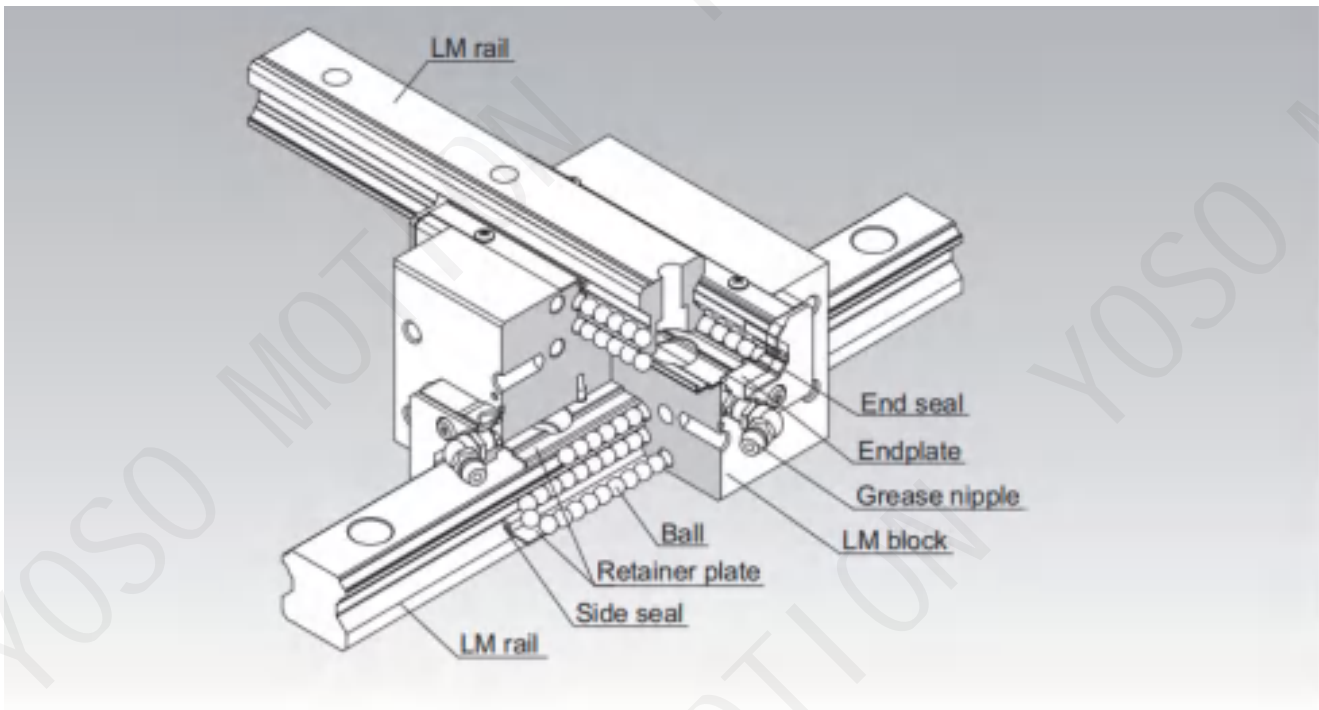

Point of Selection

Point of Design

Options

Model No.

Precautions on Use

Accessories for Lubrication

Mounting Procedure

Equivalent Moment Factor

Rated Loads in All Directions

Equivalent Factor in Each Direction

Radial Clearance

Accuracy Standards

Shoulder Height of the Mounting Base and the Corner Radius

Reference Error Tolerance for the Mounting Surface

Dimensions of Each Model with Options Attached

YOSO MOTION LINEAR GUIDE RAIL

YS-CSR LM GUIDE CROSS LM GUIDE MODEL

2-9-1 Structure and Features

Balls roll in four rows of raceways precision-ground on a LM rail and a LM block, and endplates incorporated in the LM block allow the balls to circulate. Since retainer plates hold the balls, they do not fall off even if the LM rail is pulled out. This is an integrated LM Guide that combines two LM rails, which have the same internal structure as the successful and established Model YGH, that intersect each other back to back. It is machined with high precision so that the hexahedral perpendicularity of the LM block is within 2µm per 100mm. The two rails are also machined with high precision in relative straightness. As a result, extremely high accuracy in orthogonality is achieved. Since an orthogonal LM system can be achieved with the Model YS-CSR alone, a conventionally required saddle is no longer necessary. This enables the structure for X-Y motion to be simplified, and the whole system can be downsized.

4-way Equal Load

Each row of balls is placed at a contact angle of 45° so that the rated loads applied to the LM block are uniform in the four directions (radial, reverse radial and lateral directions), enabling the LM Guide to be used in all orientations.

High Rigidity

Since balls are arranged in four rows in a well-balanced manner, this model is stiff against a moment, and smooth straight motion is ensured even a preload is applied to increase the rigidity.

The rigidity of the LM blocks is 50% higher than that of a combination of two YGH LM blocks secured together back-to-back with bolts. Thus, YS-CSR is an optimal LM Guide for building an X-Y table that requires high rigidity.

2-9-2 Types and Features

Model YS-CSR-S

This model is a standard type.

Specification Table

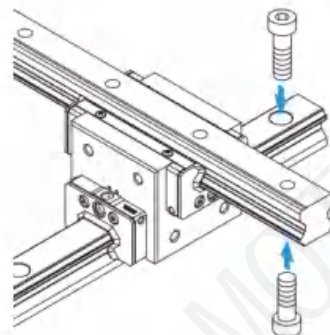

Model YS-CSR-S

It has a longer overall LM block length (L) and a greater rated load.

Specification Table

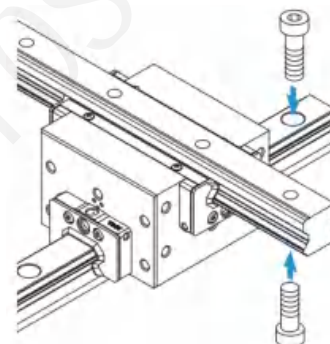

YS-CSR LM GUIDE CROSS LM GUIDE MODEL

2-9-3 Using an inner Saddle

The Model YS-CSR can easily be assembled and adjusted by using an inner saddle to link four LM blocks together. When installed on an inner saddle, the Model YS-CSR becomes a highly accurate X-Y guide and achieves high rigidity moment in the yawing direction (as indicated by the arrow in the figure).

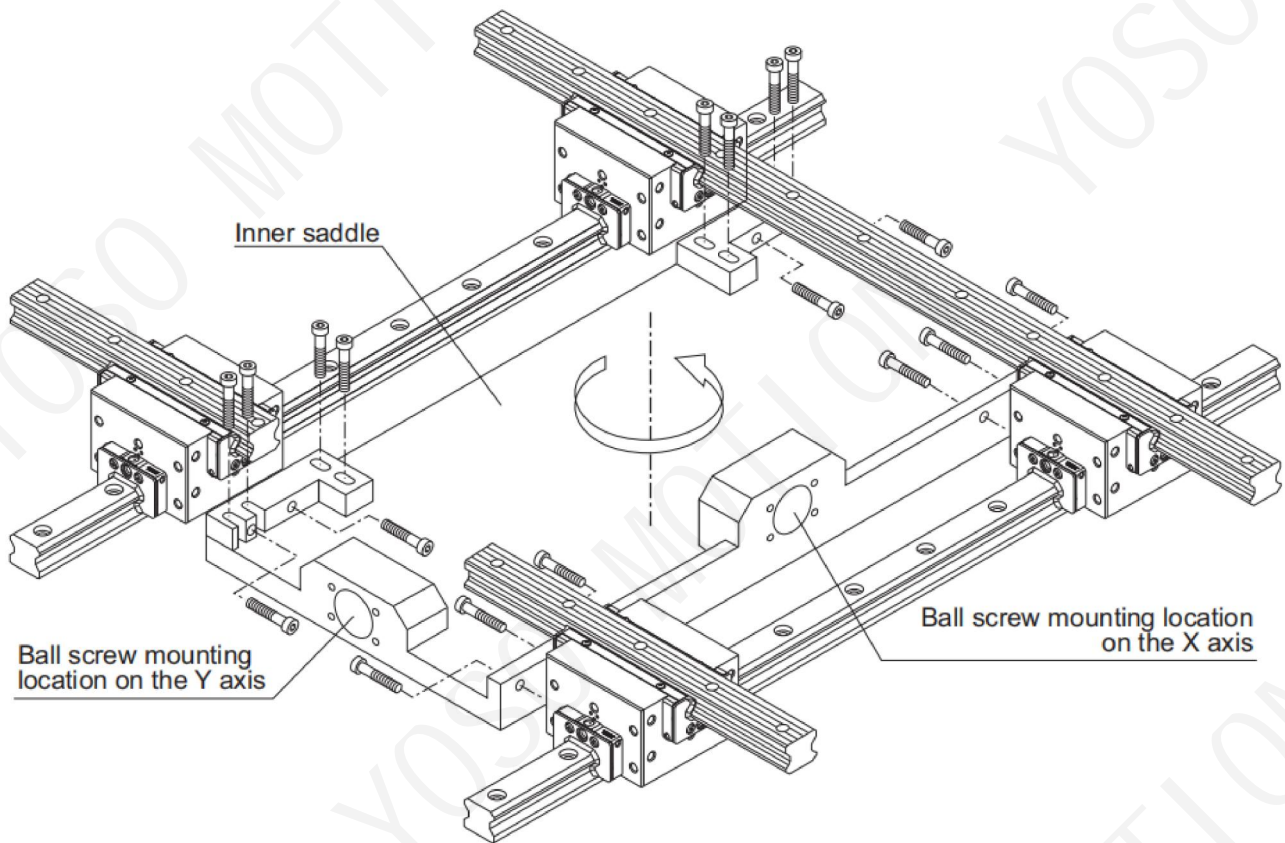

2-9-4 Model number coding

4	CSR25	UU	CO	+120011000L	P
Total No. of LM blocks	Model number	Contamination protection accessory symbol (*1)	LM rail length on the X axis (in mm)	LM rail length on the Y axis (in mm)	Accuracy symbol (*3)
		Radial clearance symbol (*2) Normal (No symbol)/Light preload (C1) Medium preload (C0)			Precision grade (P)/Super precision grade (SP) Ultra precision grade (UP)

(*1) See contamination protection accessory on

YOSO MOTION LINEAR GUIDE RAIL

YS-CSR LM GUIDE CROSS LM GUIDE MODEL

Model YS-CSR-S

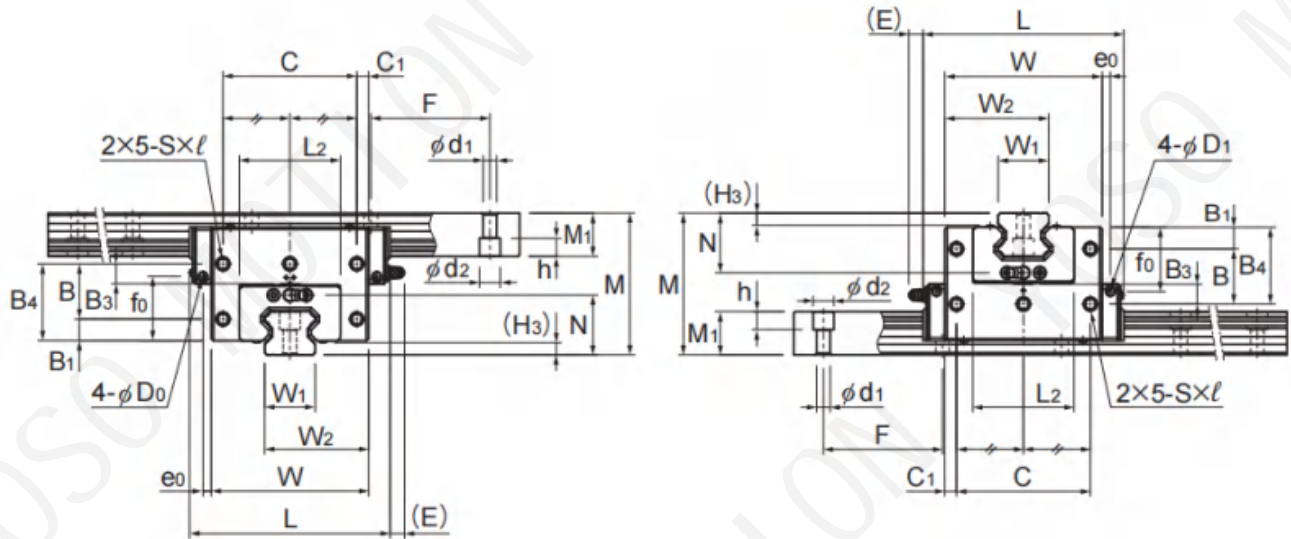

Model No.	Outer dimensions			LM block dimensions													
	Height M	Width W	Length L	B ₁	B ₃	B ₄	B	C	C ₁	Sxℓ	L ₂	N	E	e ₀	f ₀	D ₀	Grease nipple
YS-CSR 15	40	38.8	56.6	-	11.0	34.8	-	20	9.4	M4x6	32	19.7	5.5	3.2	22.1	3	PB1021B
YS-CSR 20S YS-CSR 20	57	50.8 66.8	74 90	- 13	12.7 7.2	42.5 37	- 24	20 36	10.4 5.4	M5x8	42	25	12	3.1	24.8	3	B-M6F
YS-CSR 25S YS-CSR 25	70	59.5 78.6	83.1 102.2	- 18	16.4 8.4	52 44	- 26	34 64	12.75 7.3	M6x10	16	30	12	3.5	30.5	3	B-M6F
YS-CSR 30S YS-CSR 30	82	70.4 93	98 120.6	- 21	19.4 11.4	61 53	- 32	40 76	15.2 8.5	M6x10	58	35	12	5.2	38.2	5.2	B-M6F
YS-CSR 35	95	105.8	134.8	24	13.3	61	37	90	7.9	M8x14	68	40	12	5.5	43.1	5.2	B-M6F
YS-CSR 40	118	129.8	170.8	30	15.4	75	45	100	9.9	M10x15	84	50	16	6.4	53.1	5.2	B-PT1/8

YS-CSR LM GUIDE CROSS LM GUIDE MODEL

ModelYS-CSR-S

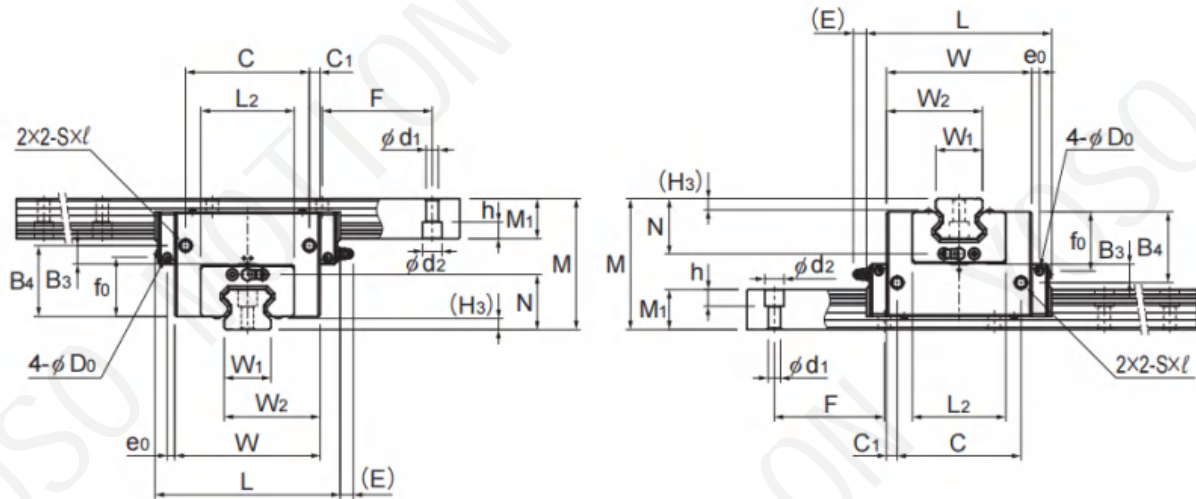

H ₃	LM rail dimensions						Basic load rating		Static permissible moment*		Mass	
	Width W ₁ ±0.05	W ₂	Height M ₁	Pitch F	d ₁ x d ₂ x h	Length* Max	C kN	C ₀ kN	M ₀ kN.m	M _s kN.m	LM block kg	LM rail kg/m
4.7	15	26.9	15	60	4.5x7.5x5.3	3000	10.9	15.7	0.0945	0.0945	0.34	1.5
4	20	35.4 43.4	18	60	6x9.5x8.5	3000	19.8 23.9	27.4 35.8	0.218 0.307	0.218 0.307	0.73 1.3	2.3
5.5	23	41.25 50.8	22	60	7x11x9	3000	27.6 35.2	36.4 51.6	0.324 0.518	0.324 0.518	1.2 2.2	3.3
7	28	49.2 60.5	26	80	9x14x12	3000	40.5 48.9	53.7 70.2	0.599 0.852	0.599 0.995	2 3.6	4.8
7.5	34	69.9	29	80	9x14x12	3000	65	91.7	1.37	1.37	5.3	6.6
10	45	87.4	38	105	14x20x17	3000	100	135	2.59	2.59	9.8	11

Note1) "Length*" indicates the standard maximum length of an LM rail.
 The maximum length under 1 block: the static permissible moment with one LM block
 Static permissible moment The total block length L shown in the table is the length with the dust proof parts, code UU or SS.
 Total block length L If other contamination protection accessories or lubricant equipment are installed, the total block length will increase.

Note2) The Model YS-CSR is not available with an upper surface lubrication hole.

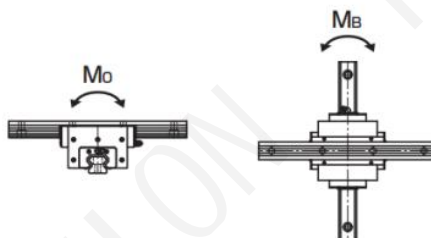

YOSO MOTION LINEAR GUIDE RAIL

YS-CSR LM GUIDE CROSS LM GUIDE MODEL

2-9-5 Standard Length and Maximum Length of the LM Rail

Table1 shows the standard lengths and the maximum lengths of model YS-CSR variations. For special rail lengths, it is recommended to use a value corresponding to the G,g dimension from the table. As the G,g dimension increases, this portion becomes less stable, and the accuracy performance is severely impacted.

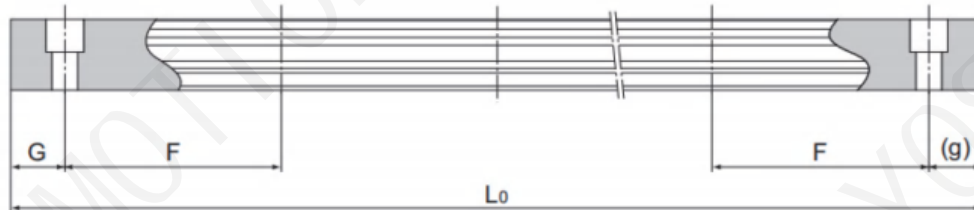

Table1 Standard Length and Maximum Length of the LM Rail for Model CSR

Model No.	YS-CSR15	YS-CSR20	YS-CSR25	YS-CSR30	YS-CSR35	YS-CSR45
	160	220	220	280	280	570
	220	280	280	360	360	675
	280	340	340	440	440	780
	340	400	400	520	520	885
	400	460	460	600	600	990
	460	520	520	680	680	1095
	520	580	580	760	760	1200
	580	640	640	840	840	1305
	640	700	700	920	920	1410
	700	760	760	1000	1000	1515
	760	820	820	1080	1080	1620
	820	940	940	1160	1160	1725
	940	1000	1000	1240	1240	1830
	1000	1060	1060	1320	1320	1935
LM rail standard length (L0)	1060	1120	1120	1400	1400	2040
	1120	1180	1180	1480	1480	2145
	1180	1240	1240	1560	1560	2250
	1240	1360	1300	1640	1640	2355
	1360	1480	1360	1720	1720	2460
	1480	1600	1420	1800	1800	2565
	1600	1720	1480	1880	1880	2670
		1840	1540	1960	1960	2775
		1960	1600	2040	2040	2880
		2080	1720	2200	2200	2985
		2200	1840	2360	2360	3090
			1960	2520	2520	
			2080	2680	2680	
			2200	2840	2840	
			2320	3000	3000	
			2440			
Standard pitch F	60	60	60	80	80	105
G,g	20	20	20	20	20	22.5
Max length	3000	3000	3000	3000	3000	3090

Note) The maximum length varies with accuracy grades. Contact YOSO for details.

YS-CSR LM GUIDE CROSS LM GUIDE MODEL

2-9-6 Tapped-Hole Type LM Rail

The model YS-CSR variations include a type with its LM rail bottom tapped. With the X-axis LM rail having tapped holes, this model can be secured with bolts from the top.

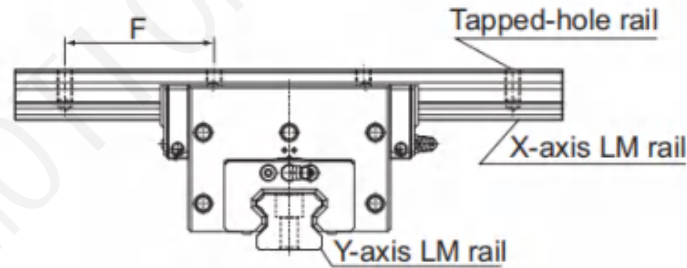

Table2 Dimensions of the LM Rail Tap

Model No.	S _t	Effective tap depth t ₁
15	M5	8
20	M6	10
25	M6	12
30	M8	15
25	M8	17
45	M12	24

2-9-7 Model number coding

4YS-CSR25UUC0+1200LPK1000LP

Symbol for
tapped-hole LM rail type



YOSO German quality, Industrie 4.0 best platform



High speed



Heavy load



Precise

Focusing on the research and production of high-speed heavy-duty precision ball screws

Jingpeng Machinery Equipment (Shanghai) Co., Ltd.

Contact information:

☎ Telephone: 0086-13636560152

📍 Address: Room 1913, Linton Building, Jing'an District, Shanghai

🌐 Website: www.yosomove.com



Whatsapp